

T 540

OMF Bangkok Library

**CHRISTIAN REVIVAL IN THE PRESBYTERIAN CHURCH OF
THAILAND BETWEEN 1900 AND 1941. AN ECCLESIOLOGICAL
ANALYSIS AND EVALUATION.**

BY

SEUNG HO SON

**DISSERTATION PRESENTED FOR THE DEGREE OF
DOCTOR OF THEOLOGY
AT THE UNIVERSITY OF STELLENBOSCH**

PROMOTER: PROF. P COERTZEN

NOVEMBER 2003

Declaration

I, the undersigned, hereby declare that the work contained in this dissertation is my own original work and that I have not previously in its entirety or in part submitted it at any university for a degree.

Signature: 

Date: September 18, 2003

ABSTRACT

This study deals with Christian revival and specifically Christian **revival** in the Presbyterian Church of Thailand. Above all, it is an in-depth ecclesiological **analysis** and evaluation of the Thai revival through John **Sung's** campaigns of 1938-1939. This is a first attempt to examine this revival from a holistic point of view. Between 1900 and 1941, missionary work in Thailand was carried on almost exclusively by missionaries of the American Presbyterian Mission (APM), and the revival was confined to the Church of Christ in Thailand (CCT) with which the missionaries were involved.

The APM missionaries' theology of revival can be understood by surveying the theological controversy over revival within the American Presbyterian Churches. There is a remarkable resemblance between the problems of the Old-New Side split of 1741 in American Presbyterianism and the Thai revival of 1938-1939. The same **problems**, of ministerial qualifications, differing understandings of the nature of true revival, and the essence of faith, **reoccurred** two hundred years later in Thailand.

The historical, **socio-cultural**, religious, and political situation in Thailand played an important role in the reception of the gospel among the Thai, as well as in the results of John **Sung's** campaigns. This is why the fruit of his ministry was meagre compared to the results of his work in other Southeast Asian countries, even though the campaigns resulted in the greatest revival movement Thailand had yet experienced. John Sung (1901-1944), the greatest evangelist China has ever known, was conservative in his theology. His theology of **revival** was coincident with Old School American Presbyterianism, but some aspects of his evangelistic methods were identical with those of the New School. Despite his errors, God **used** him mightily for the Thai church.

Forerunners of the revival movement prepared the ground for John **Sung's** Thai campaigns. Even though his itinerant ministry was conducted for only six weeks in 1938 and two months in 1939, there was a genuine spiritual revival, as is reflected in general church history, following the phenomena of conviction of sin and repentance, with restored worship and faith in God's Word, and eagerness for evangelism. The revival had positive and **negative** results. Nevertheless, the Thai church was prepared for the test of the nationalistic Buddhist movement of 1940-1941 and the people were equipped for the hardships of the Second World War. By using the Westminster

Confession of Faith as a criterion for an ecclesiological evaluation of the campaigns, it is shown that John Sung did not instigate division within the church, even though his followers tried to set themselves apart. But his criticism of the missionaries and Thai church leaders disrupted the work of the officers of the church.

When the Thai supporters of the campaigns, out of their hunger for God's Word, asked for a Bible College to be established, the leaders of the APM, due to their own limitations, rejected the suggestion. In the end the APM and the CCT lost a golden opportunity for church growth. The most important reason was that neither could work in close cooperation with the other. The central issue now is whether the Thai church can learn from the lessons of the past.

OPSOMMING

Hierdie studie handel oor **Christelike** herlewing en **spesifiek** Christelike herlewing in die **Presbiteriaanse** Kerk van Thailand. Bowenal is dit 'n grondige ekklesiologiese **analise** en evaluering van die herlewing wat in Thailand deur John Sung se veldtogte in 1938 en 1939 teweeggebring is. Dit is 'n eerste poging om die herlewing **vanuit** 'n holistiese oogpunt te bestudeer. Tussen **1900** en **1941** is sendingwerk in Thailand feitlik juitsluitlik deur sendelinge van die **Amerikaanse** Presbiteriaanse Sending (APS) **ondernem**, en die herlewing was beperk tot die Kerk van **Christus** in Thailand (KCT) **waarin** hierdie sendelinge **werksaam** was.

Die **APS-sendelinge** se herlewingsteologie is **begrypbaar** wanneer ons die teologiese twispunte oor herlewing **binne** die Amerikaanse Presbiteriaanse Kerke bestudper. Daar is **merkwaardige** ooreenstemming tussen die skeuring van 1741 tussen die Ou en Nuwe Bedeling in Amerikaanse Presbiterianisme en die herlewing van 1938-1939 in Thailand. **Dieselfde** probleme, te wete die **kwalifikasies** van **bedienaars**, verskille in die verstaan van die **aard** van ware herlewing en die wese van geloof, het twee honderd **jaar** later ook in Thailand **opgeduik**.

Die historiese, **sosio-kulturele** en politieke situasie in Thailand het 'n **belangrike rol** gespeel in die **ontvanklikheid** vir die **evangelie** onder die Thai, **sowel** as in die **resultate** van John Sung se veldtogte. Dit is **hoekom** die **vrug** van sy bediening **skamel** was in **vergelyking** met die resultate van sy werk in **ander** Suidoos-Asiatiese **lande**, alhoewel die veldtogte **wel gelei** het tot die grootste herlewingsbeweging wat Thailand ooit beleef het. John Sung (1901-1944), die grootste **evangelis** wat China ooit geken het, het 'n **konserwatiewe** teologie **beoefen**. Sy herlewingsteologie het saamgeval met die Ou **Skool** van Amerikaanse Presbiterianisme, **maar** sommige aspekte van sy **evangelisasiemetodes** was identies **aan die** van die Nuwe Skool. Ten spyte van sy foute, het God **hom kragtig gebruik** in diens van die kerk in Thailand.

Voorlopers van die herlewingsbeweging het die land vir John Sung se veldtogte in Thailand voorberei. Alhoewel sy rondreisende bediening **slegs** oor ses weke in **1938** en twee **maande** in **1939** gestrek het, was daar 'n ware geestelike herlewing **soortgelyk** aan wat in die algemene kerkgeskiedenis **weerspieël** word, wat gevolg het op 'n **oortuiging** van sonde en **inkeer**, met **hernude aanbidding** en geloof in die Woord van God en **evangelisasie-ywer**. Die herlewing het positiewe sowel as negatiewe gevolge gehad. Dit het nogtans die **kerk** in Thailand voorberei vir die toets van die nasionalistiese Boeddhistiese beweging van **1940-1941** en het **mense toegerus**

vir die **swaarkry** van die Tweede **Wêreldoorlog**. **Aan** die hand van **die** Geloofsbelydenis van Westminster as **'n kriterium** vir die ekklesiologiese evaluering van John Sung se veldtogte, word getoon dat hy nie verdeeldheid in die kerk **aangespoor** het nie, alhoewel sy volgelinge probeer het **om** hulself af te sonder. Sy **kritiek** op die sendelinge en **kerkleiers** in die kerk het egter die werk van die **kerkbeamptes ontwig**.

Toe die **Thailandse ondersteuners** van die veldtogte uit **hul** honger **na** die Woord van God die oprigting van **'n** Bybelkollege versoek het, het die leiers van die APS die voorstel **vanweë** hul eie **tekortkominge** van die hand gewys. So het die APS en die KCT **'n** geleentheid vir kerkgroei verloor. Die **vernaamste** rede **hiervoor** was die **onvermoe** van beide om met **mekaar saam** te werk. Tans is die sentrale vraagstuk of die kerk in Thailand uit die **lesse** van die verlede kan leer.

ACKNOWLEDGMENTS

To God be the glory for ever! Amen.

I am deeply grateful to all who have made their significant contribution to the completion of this study academically, spiritually and financially: Prof P Coertzen, Dr John R Davis, the National Women's Mission of the Korean Presbyterian Church (Kosin), many supporting churches, the Payap University Archives, the Historical Office of the Church of Christ in Thailand, all the staff and students of the Phayao Bible College, my friends in the Korea Presbyterian Mission and the Overseas Missionary Fellowship, and my family (my wife Ok Kyung and son Joo Eun).

Map of Thailand



ABBREVIATIONS

ABCFM: American Board of Commissioners for Foreign Missions

AMA: American Missionary Association

APM: American Presbyterian Mission

CCS: Church of Christ in Siam

CCT: Church of Christ in Thailand

OHT: Oral History Interview (Preserved at the Payap University Archives, Chiangmai, Thailand)

PCUSA: Presbyterian Church in the United States of America

SPG: Society for the Propagation of the Gospel

WCF: Westminster Confession of Faith

YMCA: Young Men's Christian Association

**CHRISTIAN REVIVAL IN THE PRESBYTERIAN CHURCH OF
THAILAND BETWEEN 1900 AND 1941.
AN ECCLESIOLOGICAL ANALYSIS AND EVALUATION.**

TABLE OF CONTENTS

ABBREVIATIONS

FIGURES/v

TABLES/vi

Chapter 1. Introduction.....	1
1.1 Motivation.....	1
1.2 Problem.....	1
1.3 Purpose.....	2
1.4 Hypothesis.....	2
1.5 Methodology.....	3
1.6 Delimitation.....	4
1.7 Structure.....	5
1.8 A definition of the meaning of revival.....	6
1.8.1 Definitions of terms related to revival.....	7
1.8.2 What revival is not.....	8
1.8.3 Changing the meaning of revival in church history.....	11
1.8.4 Theology and definition of revival in Reformed tradition.....	12
1.8.4.1 God's agency and human agency in revival.....	12
1.8.4.2 God's Word and prayer as preparation for revival.....	13
1.8.4.3 Four results of revival.....	14
1.8.4.4 Definition of revival.....	15
1.9 A brief account of Thai church history (1828-1941).....	16
1.9.1 Protestant beginnings (1828-1860).....	17
1.9.2 The period of expansion (1860-1934).....	20
1.9.3 The period of the formation of a national church (1934-1941).....	23
1.10 Sources.....	26
 Chapter 2. The causes and effects of the varied understandings of revival among American Presbyterian missionaries to Thailand.....	 28
2.1 Introduction.....	28
2.2 A brief history of the division within the American Presbyterian Church before the Second World War.....	28
2.3 The theological controversy over revival within the American Presbyterian Churches..	35
2.3.1 The Old Side-New Side Controversy.....	35
2.3.2 The Old School-New School Controversy.....	40
2.4 The different concepts of revival within the American Presbyterian Mission as exemplified by a representative protagonist and a representative antagonist of John Sung's campaigns.....	42

2.5 Summary and conclusion.....	47
Chapter 3. Three factors which impinged upon and affected the result of the revival in Thailand.....	49
3.1 Introduction.....	49
3.2 Historical factors.....	50
3.2.1 The Sukhothai period (AD 1238-1438).....	51
3.2.2 The Ayutthaya period (AD 1350-1767).....	52
3.2.3 The Thonburi period (AD 1767-1782).....	53
3.2.4 The Ratanakosin period (AD 1782- present time).....	53
3.3 Socio-cultural factors.....	55
3.3.1 Characteristics of Thai personality.....	55
3.3.1.1 Ego orientation.....	56
3.3.1.2 Grateful relationship orientation.....	57
3.3.1.3 Smooth interpersonal relationship.....	59
3.3.1.4 Flexibility and adjustment orientation.....	60
3.3.1.5 Religio-psychical orientation.....	60
3.3.1.6 Form over content orientation.....	61
3.3.1.7 Interdependence orientation.....	62
3.3.1.8 Fun and pleasure orientation.....	62
3.3.2 Thai understanding and resistance to Christianity and European influences.....	63
3.3.2.1 During the first period, from 1511 to 1828.....	64
3.3.2.2 During the second period, from 1828 to about 1938.....	65
3.4 Religious factors.....	70
3.4.1 Introduction to Buddhism.....	71
3.4.2 A brief history of Buddhism in Thailand.....	73
3.4.3 Characteristics of Thai Buddhism.....	77
3.4.3.1 Animism.....	77
3.4.3.2 Brahmanism	79
3.4.3.3 Theravada Buddhism.....	81
3.4.4 Western world-view and Thai religious world-view.....	84
3.5 Some factors which influenced the Thai church before, during and after John Sung's campaigns.....	88
3.6 Summary and conclusion.....	93
Chapter 4. John Sung.....	97
4.1 Introduction.....	97
4.2 A brief history of John Sung's life and his ministry.....	97
4.2.1 Childhood and boyhood in China (from 27 September 1901 to February 1920).....	97
4.2.2 Studying in America (from March 1920 to November 1927).....	98
4.2.3 Five three-year periods (from November 1927 to 18 August 1944).....	100
4.3 Four unique features of John Sung's character.....	103
4.3.1 John Sung was a dedicated servant of God.....	103
4.3.2 John Sung was a fearless man.....	104
4.3.3 John Sung was a candid and simple man.....	104
4.3.4 John Sung was a person of an impetuous disposition	105
4.4 An analysis of the distinctive features and emphases of John Sung's theology.....	105
4.4.1 Opposition to liberal theology or the Social Gospel.....	106
4.4.2 The Word of God.....	107
4.4.3 Christology	107

4.4.4 Prayer.....	108
4.4.5 Regeneration.....	108
4.4.6 Holy Spirit.....	108
4.4.7 Sanctification.....	110
4.4.8 Church.....	110
4.4.9 Eschatology.....	111
4.4.10 Homiletics.....	112
4.5 John Sung's impact in Southeast Asia.....	115
4.5.1 An analysis of John Sung's ministry in Southeast Asia.....	115
4.5.2 A brief evaluation of John Sung's ministry in each country.....	121
4.5.3 Long-lasting impacts of John Sung's ministry in Southeast Asia.....	125
4.6 Summary and conclusion.....	128
Chapter 5. The revival movement in the Thai church.....	130
5.1 Introduction.....	131
5.2 The precursors of the revival movement—preparing the ground for John Sung's visit.....	131
5.2.1 Laos Christian Convention.....	131
5.2.2 Conference for Christian Workers.....	134
5.2.3 Biederwolf Evangelistic Campaigns.....	136
5.2.4 Mr Frank Buchman and the House Party Movement.....	137
5.2.5 The Burmese Gospel Team.....	141
5.2.6 Paul Lyn.....	144
5.2.7 Revival Committee of the Church of Christ in Thailand.....	145
5.3 John Sung's ministry in Thailand between 1938 and 1939.....	145
5.3.1 John Sung's invitation.....	145
5.3.1.1 Mr Ha Ming Tek and the Rev Sook Pongsanoi.....	146
5.3.1.2 Boonmark Gitisarn and the Church of Christ in Thailand.....	147
5.3.2 John Sung's itinerant ministry throughout Thailand.....	148
5.3.2.1 Introduction.....	148
5.3.2.2 John Sung's ministry in Nakhonpathom in 1938.....	149
5.3.2.3 John Sung's ministry in Chiangmai in 1939.....	150
5.3.3 The phenomena, characteristics and emphases of John Sung's campaigns.....	152
5.3.3.1 The phenomena of John Sung's meetings.....	152
5.3.3.2 The characteristics of John Sung's preaching.....	155
5.3.3.3 The emphases of John Sung's ministry.....	157
5.3.4 The receptivity to the gospel of the Chinese Thai and the Thai.....	159
5.4 Summary and conclusion.....	161
Chapter 6. An analysis and evaluation of John Sung's ministry.....	163
6.1 Introduction.....	163
6.2 An analysis and evaluation of John Sung's ministry in Thailand.....	163
6.2.1 Differences of opinion between protagonists and antagonists of John Sung's campaigns.....	163
6.2.1.1 The opinion of the protagonists.....	163
6.2.1.2 The opinion of the antagonists.....	165
6.2.2 Results of John Sung's campaigns.....	169
6.2.2.1 Positive results of John Sung's campaigns.....	169
6.2.2.2 Negative results of John Sung's campaigns.....	173
6.2.3 Bible College controversy and the qualifications of the ministers.....	175
6.2.3.1 Bible College controversy.....	176

6.2.3.2 The controversy regarding the qualifications of the ministers	178
6.2.4 An ecclesiological evaluation of John Sung's ministry	179
6.2.5 The historical significance of John Sung's campaigns in terms of the development of the church in Thailand.....	182
6.3 An analysis of John Sung's theology of revival.....	185
6.3.1 Theology of revival.....	185
6.3.2 Methodology of evangelism.....	187
6.4 Useful lessons to learn from John Sung's campaigns.....	189
6.4.1 The lessons for the American Presbyterian Mission.....	190
6.4.2 The lessons for the Thai church.....	192
6.5 Summary and conclusion.....	193
6.6 Final observations and summary.....	197
BIBLIOGRAPHY.....	201

FIGURES

Figure 1. Presbyterian Family Connection.....	34
Figure 2. Western Two-Tiered View of Reality.....	86
Figure 3. A Holistic Theology.....	87

TABLES

Table 1. Missionary Societies in Thailand 1828-1941	17
Table 2. The Increase and Decrease of the Communicant Members of the CCT between 1934 to 1940	25
Table 3. Summary of the Three Religious Sub-System of Thai Religion	84
Table 4. Detailed Statistics of the Countries in Southeast Asia Visited by John Sung between 1935 and 1940	116-117
Table 5. Summary of John Sung's Visits	121

Christian revival in the Presbyterian Church of Thailand between 1900 and 1941. An ecclesiological analysis and evaluation.

Chapter 1. Introduction

1.1 Motivation

During the **writer's** time as a missionary with the Overseas Missionary Fellowship in Thailand, occasions can be recalled when the need for revival within the Thai church was brought to his attention. Whenever senior missionaries who had served as church planters in Thailand retired from the mission field the author asked them, "Is it possible to **find** any effective key to open the bulwark of Thai Buddhists and to evangelise them?" He never heard any positive answers from the faithful retiring missionaries. That made him discouraged after coming from a growing church background. His high expectation towards the evangelization of the Thai people motivated him to **find** an answer, a key by which to breakthrough the resistant barrier of Thai Buddhism.

With the exception of strong Muslim countries, Thailand has become one of the most well known for its lack of fruit. The spiritual situation in Thailand led to discouragement and embarrassment for the writer. But when he read a book entitled *PrayingHyde: A present day challenge to prayer*, he received enormous help to find a possible **solution** to the problem. John Hyde groaned and cried, 'O God, give me souls or I die' (Carre [s] a):6). He became aflame for God for the revival of the Indians in Punjab, India. He was often called 'The Apostle of Prayer' (:3). It became clear that the power of God, by His Spirit, could even change the Thai who were saturated with Buddhism.

1.2 Problem

The Thai revival of 1938-1939 by John Sung's campaigns is the biggest revival movement in Thai church history. Although some studies have been made on these campaigns, little effort has been made in endeavouring to research them holistically or in depth. When we compare the significant results of revival in the Thai church, it is suprising that there has been scarcely any interest shown in its historic importance nor has it been given the credence that it deserves.

The campaigns greatly impacted Thai churches and church leaders but the data available that dealt with these highly significant events lack both consistency and accuracy. At the same time an in-depth ecclesiological evaluation of the work of John Sung has never been done before.

1.3 Purpose

The overarching purpose of this study is to investigate all related historical processes behind the emergence of the revival movements of the Thai church throughout the period 1900 to 1941 and to analyse and evaluate all relevant factors connected with its **emergence**. So that lessons, both positive and negative, may be learned and then applied to the Thai church at the present time.

Whilst various themes are included in this study, the principal **concern** is to explore in detail the phenomena, impacts and results of the revival movement in 1938 and 1939, which was led by John Sung, a Chinese evangelist. An **ecclesiological**¹ analysis and evaluation will also be considered regarding John Sung's campaigns.

The author hopes to discover some reasons why contemporary Thai people do not respond to the gospel and why the resultant fruit is so meagre, as to be relatively insignificant. This, in spite of the fact that Thailand has had a long Protestant mission history since the first residential missionary came in 1828.

This dissertation has been written in the hope that it may strengthen faith and encourage prayer for another revival in the Thai church in the near future.

1.4 Hypothesis

Firstly, the historical, **socio-cultural**, religious, and political situations of Thailand were factors that influenced the results of John Sung's campaigns.

Secondly, history records that revival was brought about through the work of John Sung in the Presbyterian Church of Thailand, that is, the Church of Christ in Thailand (CCT). The revival included the renewal of spiritual life among those already professing Christ, as well as an

¹ Ecclesiology is "[t]he study of the church as a biblical and theological topic" (McKim 1996:85).

increase desire to be obedient to the Bible. But it did not include a reorganisation of the structure of the church. In this it differed for instance, from the Reformation of the sixteenth century.

Thirdly, the American Presbyterian Mission (APM) and the CCT were not able to harvest the fruits of the revival at the time because of many limiting factors. The APM had weak points which related to their love of tradition, their theological prejudices, their lack of administrative capability, and their strong negative preconception of John Sung's ministry. They also held to an unbalanced mission strategy which was institutional centred instead of church planting centred, together with their preoccupation with social and educational work. The feeble foundation of the churches could not help to reap, or consolidate and strengthen the converts of the revival. At the same time the leaders and the missionaries of the APM and the CCT did not work together in close cooperation in the matter of the revival. The CCT did not have enough matured Christian leaders who could guide the revival movement systematically. Instead of utilising the opportunity to build up a strong church, sadly, the leaders **exploited** the situation to gain advantage for their own group's interest.

Fourthly, in spite of all the problems of the times, the revival through John **Sung's** campaigns prepared the Thai church for the testing which would come during the nationalistic Buddhist movement of 1940-1941 as well as the extreme hardships **experienced** during the Second World War.

1.5 Methodology

The Bible will be used as the norm for evaluation of John **Sung's** campaigns. K Froehlich (1991:133) described the importance of the Bible with regard to church history as follows:

Both as theological and a historical discipline church history has to do with the Bible: As a
I
theological discipline because church and Bible belong inextricably together. One of the
fundamental tenets of the ecclesiology of the Reformers was that there can be no church without
the Bible as the central witness to the Word of God in Jesus Christ...As a *historical* discipline,
church history has to do with the Bible because church history cannot be entered at any arbitrary
point.

"The Reformed tradition regards the Bible, contextually **understood**, as its basic source and **inspiration**...**The Reformation signifies a return to the Bible.**" The Word of God was reinstated

to the central position in public worship, and in the everyday lives of the people (Kim 1998:19). At the same time the Westminster Confession of Faith which defined the Reformed Confessions of Faith will be used as the standard in an ecclesiological evaluation of John Sung's ministry in Thailand.

The approach of the study will primarily be of a Reformed Theological nature—taking note of confessional, church historical, revival and revivalistic, missiological and systematic elements of theology. Reformed theology is “[t]he theological tradition that emerged from the work of John Calvin (1509-64) and other reformers such as Huldrych Zwingli (1484-1531) and Heinrich Bullinger (1504-75), in contrast to Lutheran theology. Key aspects include God's initiative in salvation, in election, and union with Christ” (McKim 1996:234). Together with this theological research, analysis and evaluation, note will also be taken of relevant religious, political and sociological circumstances. A critical and an analytical approach with reference to all sources will be used. The integral or organic methods will be used (Bradley & Muller 1995:31-32) for understanding a more holistic viewpoint in order to gain objectivity in drawing conclusions (:3).

The Harvard reference system that was consulted for achieving accuracy and consistency in the reference technique, both in the text and in the list of works, is *Form and style in theological texts: A guide for the use of the Harvard Reference System*, by Jansie Kilian, published by the University of South Africa, Pretoria (First edition 1993 (soft cover)). The author has tried to provide full references in the text but may have omitted some, merely providing page numbers. Where a page number is not fully identified by author and date, it is taken from the preceding reference work.

1.6 Delimitation

First of all, this dissertation should be understood within the context of Thailand. The term Laos refers to northern Thailand while on the other hand, Siam or Thailand refers to the whole country. During the period 1900-1941 most churches had connections with the APM because the bulk of missionary work until 1941 was carried on predominantly by American Presbyterian missionaries. The Thai revival of 1938-1939 through John Sung's campaigns is restricted among the CCT churches in which the missionaries of the APM were involved.

This study will cover the 41 year period from 1900 to 1941. Japanese troops came to Thailand on 8 December 1941. It was at that time that Thailand began to be impacted by the influence of the Second World War. This was a very turbulent period in both Thai history and church history.

In John Sung's campaigns, the Bible functioned as a primary document. The missionaries of the APM and Thai church leaders who were involved in the revival movement used the Old and New Testament in their theologies of revival. Simultaneously the leaders of the revival movements in the American church used the Bible as the implied authoritative text in all these movements. How they used the Bible in their theologies of revival (Mouton 2003) would be a very interesting study. Research into how they interpreted Scripture within the revival movements and how they used the Bible as a basis for their theological arguments would be most significant (Bosnian 2003). But it would take the writer beyond the scope of the ecclesiological analysis and evaluation of the Thai revival of 1938-1939. Therefore he does not include this area in his thesis.

The responsibility of the historian is to investigate, analyse and evaluate historical material. That being the case, then unavoidably, the historian's confessional **presuppositions** must inevitably have a part in interpreting the material. Even if objectivity is crucial for the interpretation of the materials, entire objectivity is never attainable (Bradley & Muller 1995:48). The writer's theological position is in accord with Reformed theology, so that will influence his approach in evaluating the historical material.

In order to avoid confusion, the names of places in Thailand are **based** on the orthography which was used in *Chinese society in Thailand: An analytical history* (Skinner 1957:viii-ix). This is because there are so many ways to spell English names of a place in Thailand.

1.7 Structure

Chapter one consists of a general introduction and a definition of the meaning of the revival. Using an historical approach, it gives a brief description of Thai Protestant church history in chronological order from its commencement until 1941.

Chapter two deals with the causes and effects of the varied **understanding** of revival among APM. A brief history of the division and the theological controversy over revival within the American

Presbyterian Church will be analysed. It will be compared to the different interpretations of the meaning of revival within the APM. Representative protagonists and antagonists of John Sung's campaigns are presented as examples of the differing schools of thought.

Chapter three introduces the historical, **socio-cultural** and religious factors which influenced the result of the Thai revival of 1938-1939. Prime Minister **Phibunsongkhram's** nationalism programme which exercised a direct influence on the lives of the Thai Christians during John Sung's campaigns will be explained.

In Chapter four a brief history of John Sung's life and ministry is addressed. It is necessary to understand his characteristics, theological distinctives and emphases. His ministry and impact in Southeast Asia will also be considered.

In Chapter five, by using the 'diachronic model,' we will investigate the precursors of the revival movements that prepared the ground for John Sung's campaigns in Thailand. John Sung's ministry in Thailand between 1938-1939, including the observable phenomena, characteristics, emphases and the response to the gospel by the Chinese Thai and Thai will be examined.

Chapter six is an analysis and ecclesiological evaluation of John Sung's campaigns in Thailand. John Sung's theology of revival and useful lessons that can be learned from the campaigns will be noted. The end of Chapter six presents the summary and conclusion of the dissertation. It will seek to verify the actual nature of the problems encountered and confirm the hypotheses put forward in Chapter one.

1.8 A definition of the meaning of revival.

"The greatest need of this generation is a wholehearted return to **the** plan and purpose of God" which is revival (Roberts 1991:9). Even though we cannot regard revival as the only answer to the **church's** problems, yet it could be considered as the best answer. It would not be wise to neglect the regular work of the Holy Spirit in the church and be interested in the subject of revival only (Lloyd-Jones 1987:15). It needs to be accepted that "God has more than one way of working" (Murray 1990:385). But it is the conviction of many Christians that revival will bring extraordinary results to the church in a short period of time and bring "great masses of people to their senses and to God" (Roberts 1991:10).

Even though there were many revivals in biblical history and in church history (Riss 1988:11-16), probably the word *revival* "is one of the church's most abused terms" (Kaiser 1999:2). "Edwin Orr, one of our greatest authorities on the subject of revival, reported having seen two churches in a town in America both advertising revival meetings. One displayed a board saying, 'Revival here every Monday night,' whilst the other promised: 'Revival here every night except Monday!'" (Edwards 1997:25). Therefore we need a correct understanding of the concept of revival.

Attempts have often been made to make a comparison between the phenomenon which we call revival in contemporary English usage and the word revival in verb form in the Old Testament. "What has been said of the English word 'revival' could be said of its French, German, Scandinavian and other equivalents" (Orr 1981:iii). The word 'revive' is from Latin *revivere*. In Latin *re* means 'again' and *vivere* means 'to live'. If we put them together the meaning is 'live again'. *Oxford English Dictionary* (Simpson & Weiner 1989:835) defines revival as "[a] general reawakening of or in religion in a community or some part of one." "All conveyed the meaning of restoration and renewal, never of missionary outreach or evangelization" (Orr 1981:iii). It frequently than it does with it" (Kaiser 1999:229). I D E Thomas (1997:16) said: should be noted that the Bible "will refer to the concept of revival without using this word more

[A]ny attempt to define revival leaves one with the feeling that there are certain words in our vocabulary which are better described than defined. And 'revival' is in that category. This may be one reason why the Bible gives us no precise definition of revival, but prefers the picturesque colours of description to the stolid technicalities of definition.

"We cannot go to the Bible to see how the word 'revival' is used, for it is not found there, although it contains many examples and types of revival, and unfolds all its principles" (Wallis 1956:19). Therefore it would not be necessary to analyse the etymological meanings of the word revival in the Bible (Bosnian 2003).

1.8.1 Definitions of terms related to revival

Some words that the church uses and which are related to revival are *awakening*, *renewal* and *reformation*. The words are used interchangeably. Yet despite so much being written about these terms related to revival, there remains no clear understanding of the words.

Orr (1981 :iv) said that “[a]s the sense of the word ‘revival’ suggests a renewal of life among those already possessing it, and the sense of the word ‘awakening’ suggests a coming alive to spirituality, the Oxford Association for Research in Revival has adopted ‘revival’ for believers and ‘awakening’ for community.” Revival is the work of God with the response of the believers but awakening the work of God with the response of the non-believers (Orr 1981 :v). Richard F Lovelace (1979:21-22) said:

Renewal, revival and awakening trace back to biblical metaphors for the infusion of spiritual life in Christian experience by the Holy Spirit (see Rm 6:4; 8:2-11; Eph 1:17-23; 3:14-19; 5:14). Usually they are used synonymously for broad-scale movements of the Holy Spirit's work in renewing spiritual vitality in the church and in fostering its expansion in mission and evangelism.

Renew is “[t]o make spiritually new; to regenerate.” Renewal is “[t]he act of renewing, or the state of being renewed” (Simpson & Weiner 1989:613). “*Renewals* sometimes used to encompass revival and reformation, and also to denote *aggiornamento*, the updating of the church leading to new engagement with the surrounding world” (Lovelace 1979:22). It is true that ‘revival’ and ‘reformation’ are not, in the contemporary sense, New Testament words (Edwards 1997:232).

"At Oxford, J I Packer pointed out that the Puritans in England used ‘reform’ to convey all that ‘revival’ meant in the next century” (Orr 1981:iii). Reformation refers to the renewal of life among those already possessing it, a return to the Bible which included a reorganisation of the structure of the church (Lovelace 1979:22).

1.8.2 What revival is not

"Having been used in a number of different ways over a long period of years, the word *revival* may now actually mean a variety of things” (Roberts 1991:15). In his book, *Redefining revival: Biblical patterns for missions, evangelism and growth*, William A Beckham (2000:16) stated emphatically that “[t]he ‘revival’ is part of a group of words that includes missions, evangelism, church planting, holiness and Kingdom living.” It would be useful to explain what revival is not. Then we would understand the true meaning of revival better.

Firstly, the word revival is not mass evangelism.

"Mass evangelism is work men do for Christ. *Revival* is something Christ does for men" (Roberts 1991:15). "[G]enuine revival of the people of God may precede, accompany or follow a blessed evangelism campaign, but evangelism is not revival" (Orr 1981:vii). Evangelism means proclamation of the good news in biblical terms (Watson 1977:26). Evangelism aims to reach non-believers but revival deals with the need of the church. "Every true revival results in great evangelism" (Thomas 1997:15). I DE Thomas (Thomas 1997:20-21) said:

In a revival, the human element is neither as apparent nor as important as it is in evangelism. In modern evangelistic campaigns, there is a well-known evangelist, of national or even international repute, and he may be supported by a team of specialists, including soloists, organists, choirs, personal workers, ushers, etc. There is usually vast and expensive publicity, a carefully drawn-out plan, a number of preliminary meetings, and all sorts of means are used in order to attract the people.

In an evangelistic campaign "evangelists appeal to the people" (Thomas 1997:21). In revival God is in control. When we look over the history of the New Testament and the later history of the church, whenever God revives his church evangelism flowed from that. Evangelism and revival are not in contrast with one another, but rather complement each other. They are both ways that God has used in history to build his church (:47-48).

Secondly, the word revival is not church growth movement.

The church growth movement is "a missiological movement founded by Donald A McGavran and characterised by a pragmatic approach to planting and nurturing the growth of churches, based on a systematic analysis of growing churches" (Shenk 1990:271). "The church growth movement interprets the great commission as primarily an imperative to make disciples and build and multiply churches" (Ferguson, Wright, & Packer 1998:146-147). "Most people think of revival as a time of phenomenal growth in the numbers attending church...Revival is not the conversion of thousands of unsaved, but the awakening of the church, making it holy and alive once again" (Edwards 1997:175). Most revivals "bear a close relationship to church growth" but some revivals occur without church growth (McGavran 1980:186).

Thirdly, the word revival is not emotional extravaganza.

In his historical work, *The distinguishing marks of a work of the spirit of God*, Jonathan Edwards, who was called "theologian of revival" for the eighteenth century (Orr 1981 :iii), analysed the distinguishing evidences of a work of the Spirit of God. He asserts that "[a] work is not to be judged by any effects on the bodies of men; such as tears, trembling, groans, loud outcries, agonies of body, or the failing of bodily strength. The influence persons are under is not to be judged in one way or other by such effects on the body; and the reason is because the Scripture nowhere gives us any such rule" ([1741] 1984:91). Iain H Murray (1998:134-169) expounded the dangers of fanaticism, recognition of fanaticism, consequences of fanaticism and also gave an illustration of fanaticism in the Wales revival in 1904-1905. He asserted (: 135):

Fanaticism is the opposite of a cold intellectualism. Fanaticism usually pays little attention to books, its great interest is in experiences. Fanaticism may be orthodox in belief but it is more concerned with emotion and with results than it is with objective truth and teaching.

Fanaticism puts no stress upon biblical teaching but upon the emotions of hearers (Murray 1998:147). Even though "the outpouring of the Holy Spirit has brought as much response in mind and will as in emotion, though emotional response is noticed more" (Orr 1981 :vii), "the Bible as our only infallible means of knowing the mind of God has to control both practice and spirit" (Murray 1998:169).

Fourthly, the word revival is not revivalism.

J

J Edwin Orr designates revival as having the same meaning as **revivalism** "for the movements of renewal" (1981 :v). But Iain H Murray (1994) used revival and revivalism as having different meanings in his book, *Revival and revivalism: The making and marring of American evangelicalism 1750-1858*. He defined revival as that which "retains the same mystery that belongs to the **supernaturalism** of the New Testament" (Murray 1994:379) and entitled revivalism as the organised and manipulated evangelistic meetings of Charles **Grandison** Finney (1792-1875) in which he used New Measures (Murray 1994:240-243). Therefore revivalism is defined along the lines of Iain Murray's (1994) *Revival and revivalism: The making and marring of American evangelicalism 1750-1858*.

1.8.3 Changing the meaning of revival in church history

The term revival appeared in religious usage in 1702 for the first time in Cotton Mather's *Magnalia Christi Americana* (Murray 1994:374). "During a second general awakening, 'revivalism' made its appearance in 1815, and 'revivalist' in 1820" (Orr 1981:iii). Revivalist is used as "[o]ne who promotes, produces, or takes part in, a religious revival" (Simpson & Weiner 1989:835). We should not use the word revivalist to delineate a man because the terminology leaves a wrong impression that a man can make a revival (Edwards 1997:239).

The meaning of revival has changed through the course of American church history. "Until about 1830 it would appear that one single definition of the phenomenon prevailed. A revival was a sovereign and large giving of the Spirit of God, resulting in the addition of many to the kingdom of God" (Murray 1994:374). But Charles Grandison Finney (Harding 1913:5) in his influential book, *Revivals of religion*, boldly asserted that "[a] revival is not a miracle, nor dependent on a miracle, in any sense. It is a purely philosophical result of the right use of the constituted means." He stated that the reason why people cannot experience revival is because they do not want that (Harding 1913:34). Also he declared that "*Christians* are more to blame for not being revived, than *sinners* are for not being converted" (Harding 1913:20). Charles Grandison Finney gained a national and international reputation by the **eighteen-fifties** (Sweet 1965:138).

"From the time of the first settlers in New England, the phenomenon was regarded as a 'surprising work of God'" (Murray 1994:xvii). The Puritans and Pietists and the leaders of the First Awakening emphasized God's holiness and human depravity (Lovelace 1979:83). It is a commonly accepted that the evangelical revival of the eighteenth century and the Second Awakening was unstructured and unorganised. From the 1620s to about 1858, the meaning of revival was understood as special seasons of God with his people (Murray 1994:xvii). Richard F Lovelace (1979:83) said:

Subsequent generations...gradually moved away from the Reformation in these areas. Rationalist religion...began to stress the goodness of man and the benevolence of the Deity. By the time of Second Awakening, many leaders of the revival were adjusting to this critique by presenting an increasingly kindly, fatherly and thoroughly comprehensible God. In the late nineteenth century, D L Moody determined to center his message around the truth that "God is Love" and to tone down the mention of hell and the wrath of God to the point of inaudibility.

Charles **Grandison** Finney began to structure revival meetings (Orr 1981 :vi). As the nineteenth century continued on, the different tendencies of revival became less and less distinct. "Theological differences were more and more watered down" and interdenominational evangelistic campaigns became more common (Sweet 1965: 139). "Seasons of revival became **'revival meetings.'** Instead of being **'surprising'** they might now be even announced in advance, and whereas no one in the previous century had known of ways to **secure** a revival, a system was **now...guaranteeing results...** This phase of understanding ran its course in the opening decades of the twentieth century" (Murray 1994:xviii). Orr (Orr 1981 :vi) concluded, "Finney managed to structure **'frontierrevivalism,'** which Moody in turn urbanized, while Billy Sunday made it **'big business,'** Billy Graham inheriting the development."

1.8.4 Theology and definition of revival in Reformed tradition

There is no clear and unified definition of revival in Reformed theology. The writer will accept the theology of revival of the Old School Presbyterianism, because the theology of revival of the

Old School Presbyterianism is more close to Reformed theology and Calvinism than any theology of revival among other Reformed traditions.

Old School Presbyterianism is "[t]he traditional Calvinism of 19th-century American Presbyterians upheld staunchly by professors from Princeton Seminary including Archibald Alexander (1772-1851) and Charles Hodge (1797-1878)" (Mckim 1996:194). Archibald Alexander "formed what became known as the Old School theology" (Guelzo 1999:181). Archibald Alexander, the first professor of the Princeton Theological Seminary in 1812, "formed a distinct version of Presbyterian theology that found its genesis in older, European formulations of Calvinism... .Under Alexander's direction, and due in great measure to the efforts of his colleague Charles Hodge, Princeton Seminary became the **intellectual** center of Old School Presbyterianism" (Fitzmier 1990:843).

1.8.4.1 God's agency and human agency in revival

"The supernatural working of God the Holy Spirit in revival **power** is something that no man can fully describe" (Campbell 1954:16). In every revival, there is man's side and God's side. It is necessary to understand the balance of the sovereignty of God and the responsibility of man. "Scripture taught both positions, and one without the other was in danger of becoming lopsided"

(Kaiser 1999:17-18). Iain H Murray (1998:200-211) added in the appendix of his book, *Pentecost-today?:The biblical basis for understanding revival*, an article by Hugh Martin (1822-85) taken over from the *British and Foreign Evangelical Review*. In the article Hugh Martin explains the nature and connection of the divine and human agencies in the sanctification, perseverance and final salvation of God's people with reference to **Phlp 2:12-13** (Murray 1998:200). Hugh Martin said (:206-207):

...Whether is the Divine agency or the human agency first in point of importance?...The Divine agency is indispensable, for we are not sufficient of ourselves to think anything as of ourselves, but our sufficiency is of God. And evidently also the human agency is equally indispensable, for if we are not thinking, willing, acting after a godly manner, it is clear that nought of God's sufficiency has been communicated to us, and nothing has been accomplished...God's agency is the cause of man's...we may now, without any disparagement to that which is the cause of the other, affirm that the one is just as indispensable as the other.

"God is the God of revival but man is the human agent through whom revival is possible"

(Campbell 1954:16). "The old-school understanding of revival was not formulated in forgetfulness of such vital areas of responsibility" (Murray 1998:61). "God gives promises and duties as *instrumental means* to blessing, not as *causes*, for the grace of God is in the means as well as in the result. God's act does not *follow* man's, rather the divine and human agency are conjoined so that we find that what is required of man is also attributed to God" (:62).

1.8.4.2 God's Word and prayer as preparation for revival

The two most important elements in preparing for the revival from God are preaching and teaching God's Word and praying for the outpouring of the Spirit (Ross 2000:7). Preparing the way for revival "is the recovery of knowledge and faith in God" (Murray 1998:78). John Calvin says, "[w]hether, therefore, God makes use of man's help in this or works by his own power alone, he always represents himself through his Word to those whom he wills to draw to himself." Also he said "[t]he same Word is the basis whereby faith is supported and sustained; if it turns away from the Word, it falls. Therefore, take away the Word and no faith will then remain" (Institutes 3.2.6). At the same time "[t]he Word becomes efficacious for our faith through the Holy Spirit" (Institutes 3.2.33). God works in accordance with his Word through his Spirit.

"History shows that it is when earnest prayer is multiplied that **revivals** occur" (Murray 1998:65). "Effectual prayer has a divine source and it achieves the purpose which God himself intended" (:67). But "the spirit of prayer does not originate with ourselves" (:66). "God has chosen to make prayer a *means* of blessing, not so that the fulfillment of his purposes becomes dependent upon us, but rather to help us learn *our* absolute dependence upon him" (:69). Always God places the responsibility of prayer upon us even though God takes the initiative in revival (Edwards 1997:236-237).

1.8.4.3 Four results of revival

There are both common and unique features in every revival. Many people assert different features of revival in biblical and church history. But the four most common characteristics of revival are (i) conviction of sin and repentance, (ii) restored faith in God's Word, (iii) restored worship in the church and, (iv) restored eagerness for sharing the gospel to non-believers.

Conviction of sin and repentance is an essential part of revival. "There is no revival without deep, uncomfortable and humbling conviction of sin" (Edwards 1997:116). Iain Murray (1994:163) also asserted that "[a]ll awakenings begin with the return of a profound conviction of sin." The Korean revival of 1907 is a good example of conviction of sin and repentance. "Every sin a human being can commit was publicly confessed that night... when the Spirit of God falls upon guilty souls, there will be confession, and no power on earth can stop it" (Blair & Hunt 1977:74). There was a blazing longing for holiness (Edwards 1997:28) and a desire to separate themselves from sins (Kaiser 1999:13).

"Revived individuals are...marked by their great interest in the Word of God...They will be moved to diligent study of the Bible and to faithful application of its wonderful truths to their lives" (Roberts 1991:23). Brian H Edwards (1997:64) testified to a point of historical fact that the liberal wing of the church never experienced revival because God does not trust those who will not trust his Word. Therefore "revival is an *evangelical* awakening." "One reason why the revivals experienced by **Whitefield**, Wesley and, a century later, by Charles Haddon Spurgeon continued so long was that preaching was at the center" (Edwards 1997:214). Finally the people realised the love of God which is shown in a special way through the death of Jesus Christ on the cross (Lloyd-Jones 1986:102).

The people had "a realisation of the holiness and of the majesty and the glory of God" and "a deep and terrible sense of sin" in every revival (Lloyd-Jones 1986:100-101). Calvin asserted that the Holy Spirit convicts and illumines the inner state of people (Institutes 3.2.34). Iain H Murray (Murray 1998:191) says:

When people, burdened with a sense of guilt, come to complete deliverance through faith in the atoning sufferings of Christ, and when the love of God fills the hearts of believers, then joy is irresistible. The clearer the knowledge, the higher will be the praise. At such times...something of the very happiness of heaven is manifested among the people of God.

“[E]ach revival was marked by a return to the genuine worship of Yahweh..., [G]enuine worship of the living God became the chief delight and one of the foremost desires of each person who was truly restored to spiritual vitality” (Kaiser 1999:12). “[R]ecovery of the Word of God resulted in the recovery of the worship of God” (Kim, S S 1997:71).

In many revivals, there was unusual effectiveness in evangelism. Many people were added to the congregation of the local churches in many revivals (Murray 1998:178-180). “[R]evival is the work of God with the response of the people of God, awakening the work of God with the response of the unregenerate masses” (Orr 1981:v). Large numbers of people are converted in most revivals but not all the cases (McGavran 1980:186).

1.8.4.4 Definition of revival

J Edwin Orr, historian of revivals, defined revival as "a movement of the Holy Spirit bringing about a revival of New Testament Christianity in the Church of Christ and its related community" (Edwards 1997:26). One of the best definitions of revival was suggested by Arthur Wallis (1956:20) in his classic book *In the day of Thy power: The scriptural principles of revival*:

[R]evival is a thing of special times and seasons...Numerous writings...Will confirm that revival is divine intervention in the normal course of spiritual things. It is God revealing Himself to man in awful holiness and irresistible power. It is such a manifest working of God that human personalities are overshadowed, and human programmes abandoned. It is man retiring into the background because God has taken the field. It is the Lord...working in extraordinary power on saint and sinner.

D Martyn Lloyd-Jones, "the foremost advocate of old-school views of revival in the present century" (Murray 1998:75), defined revival in his book entitled *Revival: Can we make it happen?* as "the mighty act of God and it is a sovereign act of God... Man can do nothing. God, and God alone, does it...not only can men not produce a revival, they cannot even explain it..." (Lloyd-Jones 1986:103). "If you can explain a thing it is not a miracle. A miracle is the direct, sovereign, immediate, supernatural, action of God and it cannot be explained" (:104).

The writer's definition of revival is:

A sovereign visitation of God the Holy Spirit in which God's glory is made known through God's people thereby producing authentic repentance, confession of sin and new life in Christ.

1.9 A brief account of Thai church history (1828-1941)

It is necessary to study the history of the Thai church² from the beginning until 1941 to understand the Thai revival of 1938-1939 that was brought about through John Sung's campaigns.

The history of the Thai church is described with particular reference to the development of the APM. It is no exaggeration to say that most of the Thai Protestant church history between 1900 and 1941 is related to the progress of the APM in Thailand. Paul Eakin (1944) reported on all the mission societies that had worked in Thailand from the beginning of the Protestant mission to the start of the Second World War in Thailand, from 1828 to 1941. It is clear that the biggest missionary group in the Thai church history during the period 1828-1941 comprised the missionaries from the Board of Foreign Missions of the Presbyterian Church in the United States of America (PCUSA), as shown in the following chart.

² By 'the Thai church' is meant mainly the Protestant churches in Thailand.

Table 1. Missionary Societies in Thailand 1828-1941

Society	Dates (to end of 1941)	Missionaries				Average years of service			
		Men	Wives	Single	Total	Men	Wives	Single	Total
Netherlands Mission Society	1828-1831	1	1		2	3	3		3
London Mission Society	1828-1832	1			1	4			4
Congregational ³	1831-1849	11	10	1	22	5.8	5.8	4	5.7
American Mission Association	1850-1874	5	5		10	8.6	12.6		10.6
American Baptist	1833-1893	16	15	4	35	8.8	10.8	4.5	9.2
[American] Presbyterian	1840-	153	142	68	363	14.6	14.2	11.5	13.9
American Bible Society	1893-	4	4		8	11.5	11.5		11.5
S. P. G. (England) ⁴	1902-	4	3	8	15	9.2	8.3	19	5.1
Churches of Christ (England)	1903-	6	5	2	13	10.5	11.6	19.5	12.3
Seventh Day Adventist	1918-	7	7	1	15	6.3	6.3	1	6
Christian & Missionary Alliance	1922-	7	7		14	11.7	11.7		11.7
Y. M. C. A. ⁵	1931-	1	1		2	10	10		10
Jehovah's Witnesses	1940-	2			2	2			2
Total		218	200	84	502	12.7	12.9	10.2	12.4

Source: (Eakin 1944)

We will describe Thai church history, giving priority to the advancement of the APM which became known as such after the merging of the Laos Mission and the Siam Mission that consisted of the missionaries of the Board of Foreign Missions of the PCUSA in 1920. At the same time the history relating to the APM will be delineated in more detail than in other accounts.

1.9.1 Protestant beginnings (1828-1860)

The beginning of the mission faced many difficulties. It is believed that frequent disease and the high mortality rate of the missionaries, both adult and infant, hindered mission work considerably. Poor communications presented obstacles. A particular difficulty was that Buddhism was saturated with much indigenous Animism and Brahmanism entrenched in the Siamese⁶ world-view. The Thai religion seemed to be an impenetrable stronghold for Christian

³ This refers to the American Board of Commissioners for Foreign Mission (Smith 1982:18).

⁴ This stands for the Society for the Propagation of the Gospel (McFarland [1928] 1999:372).

⁵ This refers to the Young Men's Christian Association (Wells 1958:201).

⁶ Siamese is an old-fashioned term relating to Thai, its people, or their language.

missions in **Siam**⁷. King **Pra Nang Klao** (Rama III, 1824-1851) ruled during the initial period of Protestant missions and was unfriendly to foreigners and opposed to Western innovations. The period of beginnings under King Rama III was a trying time for the missionaries (Smith 1982:29-31).

The first resident missionaries in Thailand were the Rev Carl Friedrich Augustus Gutzlaff of the Netherlands Missionary Society, a German Lutheran, and the Rev Jacob Tomlin, an Englishman of the London Missionary Society. They arrived in Bangkok on 23 August 1828 (Smith 1982:14). Their primary target was not to convert the Siamese to Christianity but to work for the Chinese diaspora living in Bangkok (Farrington 2001 :vii). "Within six months of their arrival they had translated from Chinese into Siamese the four Gospels and the Epistle to the Romans" (Wells 1958:6). Gutzlaff left for China in June 1831 and Tomlin left Siam in 1832 (Farrington 2001:viii).

The American Board of Commissioners for Foreign Missions (ABCFM) was supported by the Congregational and Presbyterian Churches jointly. They sent the first missionary to Siam in 1831 because Gutzlaff and Tomlin appealed for workers in Siam. They sent the Rev David Abeel, a medical doctor of the Dutch Reformed Church, to Siam. Twelve to twenty Chinese attended Sunday services. He baptised no converts during his stay. Finally he departed for Singapore in November 1832 because of ill health. Siam was now without an ABCFM missionary (McFarland, [1928] 1999:5-7).

The first long-term missionary of the ABCFM arrived in Bangkok in 1834. The forerunners were Charles Robinson and Stephen Johnson. Eight couples and one single lady had followed them by 1840. Dan Beach Bradley, a remarkable physician, who had a missionary career in Siam for thirty-eight years arrived in 1835. Jesse Caswell who taught Prince Mongkut, the future king, entered in 1840. Both Dan Beach Bradley and Jesse Caswell made significant impressions on the future of Christianity in Siam (Smith, 1982:23-25). The ABCFM ended their mission work in 1849 (Kim 1980:40).

⁷ "Sayam or Siam became the official name of the country only in the reign of the fourth monarch of the Chakri Dynasty-King Mongkut (1851-1868). When he signed the treaty with Great Britain on April 5, 1856, Siam was substituted for Mueang Thai for the first time and continued to be used till June 24, 1939-a period of less than one hundred years....This change was clearly stated in the State Convention Number One, which was issued by the Thai Government on June 24, 1939" (Syamananda 1988:4).

"Doctor, publisher, printer, diplomat, and evangelist, Dan Beach Bradley was the most important American missionary to go to Thailand" (Lord 1969:11). He was a missionary to Thailand from 1835 to 1873 until his death. His relationship with the ABCFM terminated in 1847 for doctrinal reasons (:12). He and Jesse Caswell then joined the American Missionary Association (AMA) which was formed by the abolitionists of the Congregational Churches in February 1848 (:11, 128-129). For about eighteen months Jesse Caswell became the tutor in English and science of Prince Mongkut, who was soon to become King Mongkut. Their ministry greatly contributed to making the missionary movement in Thailand one of the most unique chapters in the history of the Thai church (Kim 1980:41; Wells 1958:10). Even though they worked with the Congregational Churches, their denominational background was Presbyterian (Lord 1969:42). Jesse Caswell died in 1848 (Smith 1982:42).

The Rev John Taylor Jones from the American Baptist Mission arrived in Siam in 1833. The Rev William Dean who arrived in Bangkok in 1835 organised the first Chinese Baptist Church in the Far East in 1837. It was called Maitrichit Church and has continued in Bangkok to the present day (Wells 1958:16-18). The Baptist missionaries entirely suspended work among the Siamese in 1869. The Rev L A Eaton was the only survivor of the Baptist Mission in Siam and sold the Baptist premises by the Portuguese Consulate and returned to America in 1893 (Wells 1958:20-21). Thereafter Baptist missionaries from Mainland China made occasional visits for working in Bangkok. They resumed work in Thailand in 1952 (Wells 1970:7).

The PCUSA seceded from the ABCFM and organised its own Board of Foreign Missions in 1837. The Rev William P Buell and his wife arrived in Bangkok in August 1840 from the Presbyterian Board and they returned home in February 1844. Then the Rev Stephen Mattoon with his wife and Samuel Reynolds House, a medical doctor, arrived in Bangkok in March 1847. The Rev and Mrs. Stephen Bush followed them in April 1849. The first Presbyterian Church was organised without a convert on 31 August 1849 by the Bushes, Mattoons, and Dr House and the Chinese Ki-eng Qua-Sean, who had been transferred from the ABCFM. They baptised the first Siamese convert, Nai Chune, on 3 August 1859. The Presbyterians has thus taken nineteen years to win the first Siamese convert. Esther who was the adopted Siamese daughter of the Mattoons became the first Siamese woman Christian in 1860 (Smith 1982:26; Wells 1958:22-27). "As able Presbyterian missionaries kept pouring into Siam, the dawn of the Siam mission was changed into bright morning" (Kim 1980:42).

1.9.2 The period of expansion (1860-1934)

King Mongkut Pra **Chom Klao** (Rama IV, 1851-1868) ascended the throne after having spent twenty-seven years in the monkhood, which coincided with Rama III's reign. During that long period in seclusion, he acquired a profound knowledge of Buddhism. Nonetheless he was friendly to the missionaries. The missionaries tried to establish permanent mission stations as bases for the work. They began institutional work such as schools, clinics, hospitals and printing houses around those mission stations (Smith 1982:33).

The Rev Daniel **McGilvary** and the Rev Jonathan Wilson and wife arrived in Bangkok in 1858. In 1860 the Rev Daniel McGilvary married Sophia Bradley, daughter of Dr Dan Beach Bradley (Starling 1911:113). Two years later the Rev and Mrs. S G **McFarland** and the Rev and Mrs. Noah A McDonald followed (Wells 1958:29). Dr Samuel **Reynolds** House planned to go north and work among the Laos⁸ people in 1854 but was prevented by the restriction on travel by the government. "In 1861 he went to Phetchaburi to open the first mission station outside Bangkok."

He was unable to go to work in Phetchaburi because of a bad injury from a horse-riding incident (Wells 1958:30). In his place, the McFarlands and McGilvays moved to Phetchaburi and opened a new mission station under the auspices of the Siam Mission of the PCUSA in 1861. They met with the Laos and got a positive response in Phetchaburi. The McGilvays continued to pursue their vision for the Laos until they withdrew from Phetchaburi in 1866 (Swanson 1991:5).

The Siam Mission of the PCUSA opened new mission stations outside Bangkok when they obtained workers. The **Ratchaburi** Station was started by Dr and Mrs. James Thompson in 1889 (Wells 1958:119). The **Phitsanulok** Station was started by the Rev Boon **Itt**, Dr Walter B Toy, and **Kru** Tien Pow in 1899 (:113). Mr. Eckels and Guy Hamilton established a permanent mission station in **Nakhonsithammarat** in 1900 (:122). The **Trang** Station was set up by Dr L C Bulkey, **Kru** Thoon, and **Kru Juang** in 1910 (:126). They started an educational ministry as well as medical work in each mission station. The Siam Mission was able to launch a new mission station beyond Bangkok in Ratchaburi twenty-nine years after they had commenced the Phetchaburi Station in 1860.

⁸ Laos refers to North Siam. The name seems to have been borrowed from the Lao country. It is different from the Lao country that came under the dominion of France by a treaty with Siam in 1893 (Dodd [1923] 1996:230-231).

The year 1867 was a memorable year in Thai church history. The Rev Daniel McGilvary and the Rev Jonathan Wilson, the graduates of the Princeton Theological Seminary, made a trip to Chiangmai⁹ in 1863 (Swanson 1984:7). The Rev Daniel McGilvary, "The Apostle to the Lao," (Wells 1970:7) formally opened a mission station in Chiangmai on 3 April 1867. The Rev Jonathan Wilson and family followed in 1868. The missionaries received a warm reception from all classes (McGilvary 1894:373). Nan Inta, who was well-known and widely-respected, became the first convert in north Siam when McGilvary correctly predicted an eclipse in August 1868. Nan Inta received baptism on 3 January 1869. Several Lao people were baptised in 1869: Noi Sunya and Nai Boon Ma in May; Saen Ya Wichai in June; Nan Chai, Pu Sang, and Noi Kanta in August (Swanson 1984:10-12). Herbert R Swanson asserted that Nan Inta, Noi Sunya, Saen Ya Wichai, and Nan Chai came from the "middle class" of Chiangmai of those days. "In just a little over two years, the Chiangmai mission accomplished far more than the Siam Mission in Bangkok achieved in twenty long years" (:12).

The bright hope of the mission was soon clouded by the changed attitude of the prince of Chiangmai, Chao Kawilorot and the martyrdom of Noi Sunya and Nan Chai on 14 September 1869 (McGilvary 1894:373; Wells 1958:55; Swanson 1984:12-15). Herbert R Swanson (1984:20) gave a noteworthy evaluation of the martyrdom:

Kawilorot, in fact, took decisive and effective action to secure his power in the face of the threat of the new religion. He stopped the spread of Christianity, killed some of its best leaders, and destroyed the attractiveness of this alternative faith. He did all of this before the church grew large enough to embrace martyrdom as a means of strengthening the faith. The martyrs did not become the seed of the church.

In 1878 the eldest daughter of Nan Inta was to marry a Christian young man studying for the ministry. According to the custom of the Lao, the head of the family had to pay the spirit-fee for furnishing a feast for the spirits. If the Christians were to pay the spirit-fee at the first Christian wedding in northern Siam, it would mean surrender of a Christian principle and would become an obstacle for Christian mission in the future. The Chao Uparat refused to help, suggesting that there was a need to petition the king of Siam in this matter. The Rev Daniel McGilvary appealed to King Chulalongkorn for a pronouncement on religious toleration (McGilvary 1912:207-215). The king released the Edict of Toleration on 8 October 1878 (:215-217):

⁹ Sometimes it is written as Chiengmai or Chiang Mai.

**I Praya Tep Worachun...gave the following Royal Command in reference to the same: —
That religious and civil duties do not come in conflict. That whoever wishes to embrace any religion after seeing that it is true and proper to be embraced, is allowed to do so without any restriction... That there is nothing in the laws and customs of Siam, nor in its foreign treaties, to throw any restriction on the religious worship and service of any one.**

To be more specific:—If any person or persons wish to embrace the Christian religion they are freely permitted to follow their own choice. This proclamation is to certify that from this time forth all persons are permitted to follow the dictates of their own conscience in all matters of religious belief and practice....Proclamation made...October the Eighth, Eighteen Hundred and Seventy-Eight.

The proclamation of the Edict of Toleration became the turning point for the church (McGilvary 1912:217). The Christians welcomed the Edict with joy (:219). Chiangmai became the base of the Laos Mission (Wells 1958:84). "Chiangmai presbytery was organised in 1883" (:75). The Laos Mission opened mission stations in **Lampang** in 1885, in Lamphun in about 1891, in **Phrae** in 1893, in **Nan** in 1894 (Ellinwood 1896:340), and in Chiangrai in 1897 (Wells 1958:103). The missionaries became involved in tribal work among the Lahu, the **Khamu** (Swanson 1984:49-51), and the Karen (: 143) tribal groups as well as the Chinese (: 144). In 1895, the Laos Mission had 1,841 communicant members in twelve churches whereas the Siam Mission had 292 communicant members in seven churches (Ellinwood 1896:340). In only one year, 1895, the Laos Mission added 305 communicant members more than the total of all the communicant members of the Siam Mission during the sixty-seven years from 1828 to 1895. In 1903, the Laos Mission had sixteen churches and 2,738 communicant members (Wells 1958:89).

In the latter part of 1911, an epidemic of malignant malaria started in northern Siam (Swanson 1984:139). Smallpox appeared in Lampang in March 1912 (Personal and Otherwise 1912:50). The epidemic was over by 1916 (Swanson 1984:139), but plague had brought about an amazing numerical church growth. *The Laos News* (Personal and Otherwise 1912:43) reported:

In Chiengmai province alone over TWELVE HUNDRED PERSONS have renounced the worship of the spirits and entered the Christian religion as direct spiritual returns from the work done during these epidemic days. During the month of March (1912) there were FOUR HUNDRED AND THIRTY-SIX baptisms in the Chiengmai Churches. Every week witnesses new accessions.

The Laos Mission employed many Christians to distribute quinine to the people. Large numbers died although many others were as converted to Christianity because of the efficacy of the medicine. The churches in the Laos Mission grew from 4,038 members in 1910 to 5,218 members in 1912. The numbers soared to 6,934 in 1914 (Swanson 1984:170).

The Laos Mission merged with the Siam Mission in 1920. The only reason, in fact, for the existence of two Presbyterian Missions in Siam was the difficulty of communication between Chiangmai and Bangkok. The completion of the railroad between the two cities solved that problem (Wells 1958:84). Nevertheless, as alleged by Alex G Smith, the preoccupation of the missionaries with educational work seriously diminished church growth between 1914 and 1937. There were only 469 new members in nine years between 1914 and 1925 whereas 131 members were lost in twelve years between 1925 and 1937 (Smith 1982:163).

1.9.3 The period of the formation of a national church (1934-1941)

Even though the new national church, the Church of Christ in Siam (CCS), was established as the only national church in 1934, the thought and movement towards establishing a national church had appeared before that time. The idea of organising a national church appeared for the first time in 1902 when Arthur J Brown, the Secretary of the Board of Foreign Missions of the PCUSA, visited Thailand (Pongudom 1984:41). In about 1925 a Thai Christian leader, the Rev Pluang Sudhikam, as well as Chinese church leaders expressed the desire of taking over the leadership from the missionaries (:42-44).

But Pongudom insists that these were only some of the factors which delayed the commencement of a national church in Thailand. There were also the social and political factors. The social circumstance related to a patron-client system which was passed down in Thai society, a system of mutual help between overlord and vassal. Under the patronage of the missionaries, Thai Christians were willing to accept the authority of the missionaries and to depend upon the missionaries for help. Secondly, regionalism in Thailand which divided two different cultures and languages prevailed between northern Siam and south Siam. The Laos Mission in the north and the Siam Mission in the south were related to the regionalism in Thailand. An important political factor was the growth of nationalism during King Rama VI's reign (1910-1925). This movement affirmed to the Thai that Christianity was the religion of foreigners and that Buddhism was the religion of the Thai (Pongudom 1984:45-50). On the other hand there were

some other elements which accelerated the movement to establish a Thai national church. The union of the Laos Mission and Siam Mission in 1920 became an impetus for the movement. In 1921 the Board of Foreign Missions of the PCUSA held a meeting to promote a national church movement. There was also an awakening among Chinese church leaders in Thailand in 1925 when Cleland McAfee visited Thailand (:51-52). Internally, in 1923, the Thai tried to set up a primary school and a church that could be self-supporting in the north. The celebration of the centenary of Protestant church in Thailand in 1928 fostered the movements also (:53-58).

Between 1929 and 1934 there were more important developments which encouraged a national church movement. In February 1929 John R Mott gave guidelines for establishing a Thai national church when he had meetings with Thai church leaders and missionaries to discuss the outcomes of the Jerusalem Conference of the International Missionary Council (Wells 1958:138-139). The economic depression which began in America in 1929 contributed to the coup d'etat on 24 June 1932 in that the Thai government was changed from an absolute, to a constitutional monarchy. The risk of a world war enhanced the efforts of those Thailand missionaries who would form an indigenous church. The Siam National Christian Council was formed on 6 January 1930. The National Christian Council asked the Synod of New York to relieve the north Siam and the south Siam Presbyteries in order that they might form a national church and the request was granted on 19 October 1932 (:142-143).

The first General Assembly of the new church held in Bangkok on 7-11 April 1934, accepted a constitution and chose the name: The CCS¹⁰ which afterwards was changed to the CCT in 1940, following the Government's decision to use "Thailand" instead of "Siam" from 1939 on (Pongudom 1984:79-80). This constituted the Presbyterian and American Baptist (Chinese) churches as the only members of the CCT. They elected the Rev Pluang Sudhikam as the Moderator, Mrs. G B McFarland as the General Secretary, the Rev Boonmark Gitisarn as the Assistant General Secretary, and teacher Leck Taiyong as the Treasurer (:65-67). The church was divided into seven districts and three committees for evangelism, education and medical work (:80-81). The long endeavors of establishing a Thai national church from 1902 to 1934 became a reality in the setting up of the CCT.

¹⁰ Because of the change of the official name of the country from Siam, to Thailand in June 1939, the Church of Christ in Siam (CCS) was renamed the Church of Christ in Thailand (CCT) in 1940. Both names have been employed indiscriminately for the sake of variety.

A general overview of the status of the CCT from 1934 to 1941, from its establishment up to the outbreak of the Second World War in Thailand when the Japanese army invaded Thailand in December 1941, shows that the church did not have real authority over administration and finance. Even though the original aim of a national church was to establish churches to be self-supporting, self-governing and **self-propagating**, nevertheless the CCT did not reach that goal (Pongudom 1984:71). The CCT still had to depend for its missionary work on funds from overseas and on other important activities. The status of the national church in many ways was the same as it had been in the past. The American Presbyterian Mission attempted to delegate responsibility for the missionary work on the Thai Christians, but they were not able to carry out this work independently. The second General Assembly of the CCT was held in Chiangmai in April 1937 (:72-75). They elected almost the same officers as in 1934 except for the exchange of the position between Mrs. G B McFarland and the Rev Boonmark Gitisarn (:81).

Table 2. The Increase and Decrease of the Communicant Members of the CCT between 1934 to 1940.

Year	Communicant members
1934	9,412
1935	9,124
1936	9,062
1937	8,408
1938	8,413
1939	8,906
1940	9,399

Source: Office of C.C.T. (Smith 1982:183, 197)

If we look at the increase and decrease of the communicant members of the CCT between 1934 to 1940, as depicted in Table 2, there is enough evidence to show significant decline in the growth of the church during the period.

On the other hand we can see the clear evidence of the rise in church membership in 1939 and 1940 because John Sung, a Chinese evangelist, visited Thailand and conducted meetings in every mission station during 1938 and 1939 (Smith 1982:197). The Japanese army, requiring the right of transit for its troops to attack Burma and Malaysia from Thailand, landed in Thailand on 8 December 1941. The Thai government had agreed to the Japanese demand (Jumsai 2000:419).

All the missionaries exiled from the land and the Thai church became the responsibility of the Thai Christian leaders (Pongudom 1984:90-94).

1.10 Sources

Firstly, English, Thai, Korean, and Chinese language sources will be used. The writer, as a Korean has used English as the official language in the Overseas Missionary Fellowship for twelve years. He has also used the Thai language for eleven years as a missionary of church planting and as a Bible teacher at a Bible College. He understands Chinese because the Korean language incorporates a large number of words borrowed from the Chinese language.

Secondly, many valuable materials were found in South Africa. The materials relating to American church history, revival and Thailand, available from the library of the Stellenbosch University, were investigated. Regular use of interlibrary loans through the inter-loan system was made. Important Journals which are related to Thai church history like *Missionary Review of the World* and *International Review of Missions* and other periodicals at the Theological library and the main library of the University of Stellenbosch regarding church history, world missions, sociology and religious studies were consulted.

Thirdly, abundant resources were collected in Thailand. The Payap University Archives, Chiangmai, Thailand, has a large collection of materials relating to the history of Protestant missions and churches in Thailand. There are many primary and secondary sources which consist of the correspondence of the missionaries, photographs, books, articles, missionary records, theses, microfilm records, church records and interviews on tape recordings. The library of the Office of the History of the CCT, Chiangmai, Thailand, has some materials relating to the American and European cultural sources of Protestant missionary activity and the **sociocultural** and religious setting of Protestantism in Thailand. The theological library of the McGilvary Faculty of Theology, Chiangmai, Thailand, provides many resources regarding Thailand, the Thai churches and theology. The **Cross-Cultural** Training Centre, Chiangmai, Thailand, holds key information on Thai Buddhism and Thai culture. The three main bookstores in Thailand with many branches all over Thailand *i. e.* **Duang Kamol** Bookshop, Surawong Bookshop and Asia Bookshop, retain many English books on the subjects of the economic and political history of Thailand, Thai Buddhism, Thai culture and Thai society. The mission home libraries of the Overseas Missionary Fellowship in Bangkok, Chiangmai, **Chiangrai**, **Prajuapkhirikhan**, the

library of the **Manorom** Christian Hospital and **Lopburi** Language Centre all contain good sources on mission work, mission history, biographies of missionaries, Thai Church, Thai Buddhism and Thai culture. The libraries of the Phayao Bible College, the Bangkok Bible College and Seminary, the Bangkok Institute of Theology contain materials concerning the history of the Thai church, Thai Buddhism, Thai culture and theology in Thai and English.

Fourthly, the writer interviewed several Thai witnesses of John **Sung's** campaigns in 1938 and 1939 and four Thai church leaders together with two missionaries who heard about the campaigns indirectly from the Thai witnesses. He interviewed them in south Thailand (Trang Province), central Thailand (Bangkok and Chainat Province) and north Thailand (Nan Province, Chiangmai Province, Phayao Province and Mae Sai) in February 1998, in April, September, October, and December 1999 and in January 2000.

Fifthly, through University Microfilms International a list of the dissertations which are related to the Thai church and revival movements in other countries was obtained.

Sixthly, it was possible to find several Korean books that related to Thailand.

Seventhly, several taped interviews which were conducted in northern Thai language were obtained from the Payap University Archives, Chiangmai, Thailand, and translated into central Thai language by the students of Phayao Bible College where the writer works. One of the best translators in Thailand is Dr Ursula Loewenthal who is a staff member of the Phayao Bible College. She translated the Thai materials into English.

Lastly, Liao Nai Fwei and Helen Young translated *Anecdotes and sayings of John Sung* (宋尚節言行錄) by Yee Ling Liu from Chinese into English. Winnie To translated a section of *The diary of his spiritual life of Dr John Sung* (靈歷集光: 主僕宋尚節博士的日記摘抄) (sic) (Sung 1995b) by Levi Tian-Zhen Song. Her translation covered John Sung's visit to Thailand in 1938 and 1939.

Chapter 2. The causes and effects of the varied understandings of revival among American Presbyterian missionaries to Thailand

2.1 Introduction

The aim of this chapter is to understand the different concepts of revival within the APM in Thailand. The American Presbyterian missionaries in Thailand were deeply involved in the Thai revival of 1938-1939 which accompanied John Sung's campaigns. John Sung, a Chinese evangelist, visited Thailand for just over three months altogether in 1938 and 1939. To analyse the above data we need to understand the ecclesiastical background of the missionaries. We will first briefly investigate the history of the division within the Presbyterian Churches in America. Following this we will consider the theological controversy over revival within the churches. Lastly, we will focus on the different concepts of revival within the APM in Thailand as exemplified by a representative protagonist of John Sung's campaigns, the Rev Loren S Hanna, and a representative antagonist, the Rev Carl Elder.

2.2 A brief history of the division within the American Presbyterian Church before the Second World War

In the beginning, Presbyterian congregations flourished in Scotland more so than in England (Smylie 1996:29). John Knox (1514-1571) spent three years in Geneva with John Calvin during which time he organised a church in Geneva for the English-speaking refugees. He returned to Scotland in 1559 and laid the groundwork for the establishment of a Presbyterian form of church government (Lingle & Kuykendall 1978:39). "[M]any Presbyterian Churches in the emerging nations can trace their ancestry to the Church of Scotland." Thus the heritage of John Calvin which was communicated to the Scots through John Knox has spread throughout the world (:45). The Presbyterian Church in Scotland had considerable influence on developments in England, Ireland, and America (Smylie 1996:31).

It is generally accepted that the settlers of the United States were predominantly immigrants who were committed to the Reformed heritage from a rich diversity of European backgrounds (Lingle & Kuykendall 1978:64). Many of the earliest settlers of the first American colony, Virginia, were Presbyterian Puritans in conviction (Loetscher 1978:57). Queen Elizabeth allowed the Protestant exiles to return from Geneva and the other refuges on the Continent. Many of them

were not satisfied with the Reformation in England. They thought that the Church of England needed to have a purer form of church government, doctrines, worship, and standards of morality. As a result of this zeal for purity, they were nicknamed Puritans (Lingle & Kuykendall 1978:48).

The largest single group of Presbyterians (Lingle & Kuykendall 1978:65) were the people of Ulster in the northern section of Ireland. Normally known in America as **Scottish-Irish**, they have deeply influenced American Presbyterianism (Loetscher 1978:42). James I wanted to bring Ireland under control and to that end, implemented a plantation system (Smylie 1996:37). That programme induced the rural tenants of England and Scotland to immigrate to the Irish province of Ulster. Most of the early settlers came from the lowland counties of Scotland and the nearby English border counties (Lingle & Kuykendall 1978:56-57). According to the change in the political situation in the British Isles a great deal of hardship was experienced by the Ulster Presbyterians. Under such difficult circumstances, large numbers of the Scottish Presbyterians in northern Ireland began to emigrate to the British colonies in North America. They formed the strong backbone of Presbyterian Churches in the colonies (:61-62). In fact, the contributions of the Scottish Reformed Church exerted more direct influence on American Presbyterianism than all the Continental churches combined (:37).

While Charles I was still king the Westminster Assembly met in Westminster Abbey in the years between 1643 and 1648. One hundred and twenty-one Commissioners from various religious backgrounds including some very capable and influential Scottish Presbyterians, met to reform the Church of England. The Commissioners composed several major documents dealing with worship, theology, and discipline, all extremely important for Presbyterians, including the Directory for Public Worship, the Westminster Confession of Faith, and the Westminster Larger and Shorter Catechisms together with the Form of Government which became known as the Westminster Standards (Smylie 1996:33-34). Ironically, the Confession eventually became the official creed of Scottish, Irish, and American Presbyterians but was never adopted in England (Moorhead 2000:20)

Francis **Makemie** from the presbytery of **Laggan** in Ireland has been called the "Father of American Presbyterianism." He organised Presbyterian Churches at Rehoboth and Snow Hill, Maryland in 1683, and later several others nearby (Loetscher 1978:60-61). He organised the first presbytery in Philadelphia in 1706 (Smylie 1996:39). In 1717 the presbytery reorganised the Synod of Philadelphia that comprised four member Presbyteries (Lingle & Kuykendall 1978:67)

which consisted of all those congregations from the British Isles (Smylie 1996:42). It was at this time that the first theological controversy arose as to whether ministers should be required to subscribe to the Westminster Confession and Catechisms as the formal expression of their beliefs. They agreed to what was called the Adopting Act in 1729 by which the Westminster Confession and Catechisms were established as the official doctrinal statements of American **Presbyterianism**. (:45). In general, ministers of Scottish and Scotch-Irish descent were in favour of strict adherence to those standards. Those of English background were typically opposed to it (Lingle & Kuykendall 1978:67).

In the late 1720's, Jacob Frelinghuysen, pastor of the Dutch Reformed Church at Raritan, New Jersey, asserted "the necessity of conversion and visible evidences of new spiritual life in professing Christians." His influence extended to Gilbert Tennent, son of William Tennent, founder of the Log College at Neshaminy, Pennsylvania. Gilbert Tennent's work began to show genuine signs of revival in 1728 at New Brunswick, New Jersey (Loetscher 1978:67). Many other ministers caught the revival spirit. This "Great Awakening" was not restricted to the middle colonies, or to any one denomination but was influential across denominational lines all over the country (Loetscher 1978:68). Gilbert Tennent preached a sermon entitled "The Danger of an Unconverted Ministry," which was a rather harsh criticism of all pastors who opposed the revivals in 1740. The sermon proved to be a catalyst in the division that happened between the Old Side and the New Side. The Old Side was opposed to what they perceived to be emotional revivalism and potential disorder in the revival movement. On the other hand the New Side understood Old Side people to be in danger of spiritual decline and atrophy. At the meeting of the Synod in 1741, the Old Side majority declared that the presbytery of New Brunswick, of which most of the New Side revivalists were members, was no longer a part of the Synod of Philadelphia (Lingle & Kuykendall 1978:68). We shall study the division in more detail in Chapter 2.3. Not long after the division, reunion was achieved between the Synod of Philadelphia of the Old Side and the Synod of New York of the New Side on the basis of the Westminster Standards in 1758 (Loetscher 1978:70). The reunited church called itself the Synod of New York and Philadelphia (Lingle & Kuykendall 1978:69). The Synod organised the General Assembly in 1788 with the four subordinate Synods of New York and New Jersey, Philadelphia, Virginia, and the **Carolinas**. The church now took as its official name "The Presbyterian Church in the United States of America (**PCUSA**)" (Loetscher 1978:76-77). They amended portions of the Westminster Standards in order to apply it to the American context. In

May 1789, the first General Assembly of the PCUSA was held in Philadelphia (Lingle & Kuykendall 1978:71).

There was a remarkable revival of religion during the last years of the eighteenth century (Lingle & Kuykendall 1978:72). In the early years of the 1800s, Presbyterians carried on revivals and organised presbyteries and synods wherever they went (Smylie 1996:70-72). The revival which was often called the Second Great Awakening spread north and west and soon became almost nationwide (Loetscher 1978:79). In 1801, the General Assembly of the PCUSA and the Congregational Association of Connecticut agreed to a Plan of Union in order to cooperate in church planting on the frontier. As the revival movement proceeded steadily, both denominations cooperated with one another through mission societies at home and abroad (Smylie 1996:72-73). During the thirty-five years after the Plan of Union was adopted, Presbyterianism experienced remarkable growth (Lingle & Kuykendall 1978:72). This rapid growth was partially due to the great frontier revivals of the Second Great Awakening. Even the united efforts of Congregationalists and Presbyterians could not provide sufficient pastors to care for the new converts. Some Presbyterians tried to lower the level of education for the ministers and loosen the connection between American Presbyterianism and the Westminster Standards. Out of this a serious controversy arose, which resulted in the withdrawal of some Presbyterians to form the Cumberland Presbyterian Church in 1810. Even after the Cumberland split, other points of disagreement continued to plague the Presbyterian community in the early decades of the nineteenth century (Lingle & Kuykendall 1978:73). These centred round developments in worship, theology, governance, finance for missionary efforts (Smylie 1996:83) and, especially, on the controversy over slavery (:78).

The strain between the confessional and pietistic factions in the Presbyterian Church remained and reappeared in the New School-Old School schism of 1837 (Guelzo 1990:821). The Old School that had many adherents in the south was **doctrinally** more conservative than the New School (Smylie 1996:78-79). They advocated a rigid adherence to the Calvinism of Westminster Standards, a rigid control of missionary activity by the denomination and the defense of slavery as a positive good. On the other hand, the New School who had most of its support from the north favoured interdenominational cooperation in missions and identified with the anti-slavery cause (Lingle & Kuykendall 1978:73-74). New Schoolers were exploring fresh ways of expressing their Reformed theology through God's gracious love shown in Jesus Christ. "The

Old School considered itself the Reforming Party. It thought this division was the right move because of the theological and governance issues which were at stake" (Smylie 1996:79).

The breach between the two parties became wider when the Old School constituency controlled the General Assembly in 1837. They declared that the 1801 Plan of Union with the Congregational Church had been unconstitutional from the beginning (Lingle & Kuykendall 1978:74) and voted to abrogate the Union. The four Synods of Western Reserve, Utica, Geneva, and Genesee which had been organised under the Plan of Union cut off from the church. "The one church had now become two separate denominations" (Loetscher 1978:97). Both of them retained the original official name of "The Presbyterian Church in the United States of America." During the years of division from 1837 to 1869, the two churches were popularly known as New School and Old School (:98).

"The larger Presbyterian Church divided again, this time into four denominations." The New School split in 1858 when their members were dealing with the issue of slavery. "In 1858 New Schoolers in the south who favored slavery formed the United Synod of the Presbyterian Church in the United States of America." The Old School remained united until May 1861 (Smylie 1996:88). In the midst of the Secession Crisis, the General Assembly of the Old School decided to support the Federal Government. Therefore Southern Presbyterians protested and organised the General Assembly of the Presbyterian Church in the Confederate States of America in Augusta in December 1861 (:89). Later in 1866 they took the name of the Presbyterian Church in the U.S. (Weeks 1990:932). In 1869 the Old and New School Presbyterians in the north were reunited (Loetscher 1978:123) on the basis of the Westminster Standards. The name of the reunited church was the Presbyterian Church in the United States of America (:129). Meanwhile the Old and New School Presbyterians in the south had reunited in 1864 (Smylie 1996:91). In the end the four denominations consolidated into two denominations by 1869, one reunited in the north and one reunited in the south. This remaining division sustained for more than a century (Loetscher 1978:129).

As Presbyterians were encountering problems such as industrialisation and urbanization, scientific and intellectual ferment, and international expansion (Smylie 1996:94), the Presbyterian Church in the U.S.A. enacted some moderate revisions to the Westminster Confession of Faith in 1903 (Lingle & Kuykendall 1978:75). The Cumberland Presbyterian Church reunited with the Presbyterian Church U.S.A. in 1906 on the basis of the revised Confession even though about

one-third of the members of the Cumberland Church refused to go into the union (:76). Differing responses to the intellectual and social changes of the late nineteenth and early twentieth centuries produced sharp divisions especially among American Presbyterianism especially through the Fundamentalist-Modernist controversy. This controversy was an extended conflict between compromising liberals and uncompromising theological conservatives. The former pursued the goal of preserving Christianity by accommodating the traditional faith to modern culture while the other tried to save evangelical Christianity from the advances of Modernism and Darwinism (Marsden & Longfield 1990:466). Bradley J Longfield (1991) in his book *The Presbyterian Controversy: Fundamentalists, Modernists, and Moderates* examined the Fundamentalist and Modernist controversy of the 1920s and 1930s.

From 1922 until 1936 the Presbyterian Church in the U.S.A. was wracked by conflict. Sparked by a sermon of Dr Harry Emerson Fosdick, a liberal Baptist preaching in a Presbyterian pulpit, the Presbyterian controversy raged for fourteen years over such issues as ordination requirements, the mission of Princeton Seminary, and the orthodoxy of the Board of Foreign Missions. Though at the height of the conflict in the mid-1920s the church managed to hold together, the controversy resulted in a loosening of the church's ordination standards, the reorganisation of Princeton Theological Seminary, the creation of Westminster Theological Seminary, and the eventual founding of the Presbyterian Church of America (:4).

The Fundamentalists, most prominent of whom was J. Gresham Machen, stressed the need for accurate doctrine in order that the church would survive in the midst of a secular culture. The Modernists placed more stress on the unity of the church and less on doctrine. In the end the church chose pluralism in the 1920s and 1930s at the expense of doctrinal purity (Heuser 2000:107). When J. Gresham Machen, a proponent of the conservative Princeton Theology, started an Independent Board for Presbyterian Foreign Missions in 1933 (Longfield 1991:206), the General Assembly asserted the organisation was illegal (:209). The 1936 General Assembly suspended him and he moved on to found the Presbyterian Church of America in 1936 (:212). It has been known as the Orthodox Presbyterian Church since 1939. "A group withdrew from that body in 1937 to form the Bible Presbyterian Church" (Weeks 1990:932).

Figure 1 in the next page helps us to understand the Presbyterian family connection with regard to the history of the division within the American Presbyterian Church.

Figure 1. Presbyterian Family Connection *Photo credit: Presbyterian Historical Society*

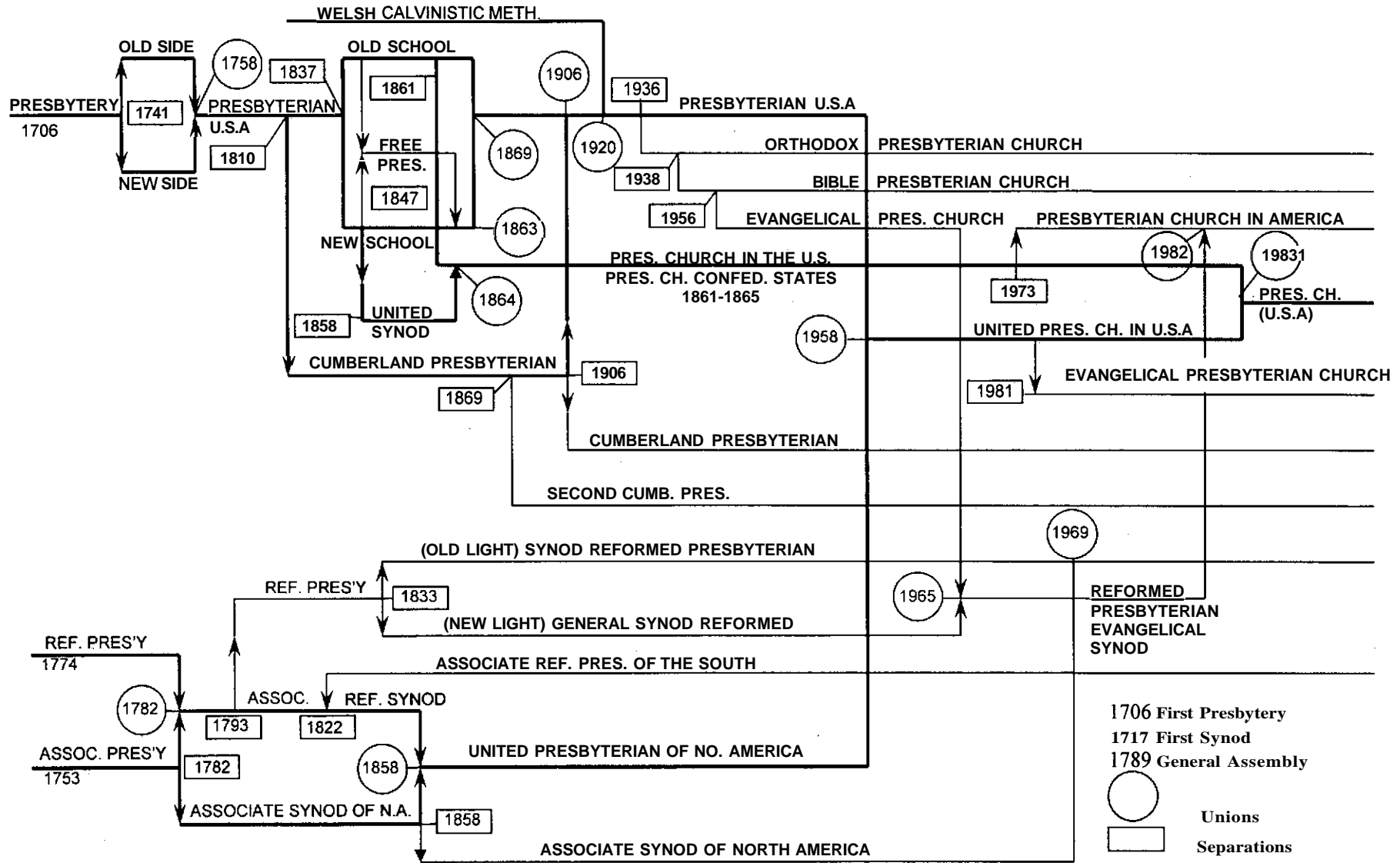

2.3 The theological controversy over revival within the American Presbyterian Churches

2.3.1 The Old Side-New Side Controversy

It is going too far to say that the theological controversy over revival within the American Presbyterian Churches had a direct impact upon the theology of revival of the American Presbyterian missionaries in Thailand in 1930s. Although the distinction between Old School and New School had become meaningless by 1870 (Swanson 2002), it is quite probable that the theological controversy over revival within American **Presbyterianism** indirectly influenced the American missionaries in Thailand at that time. Therefore we will examine the theological controversy rather briefly.

"On the surface **revivalism**¹¹ and Presbyterianism would not appear to be a likely combination." Nevertheless, since the revivals of the First Great Awakening in the eighteenth century, American Presbyterians have been associated closely with revivalism. There were Presbyterians among the leaders of the revival in the American colonies. Nevertheless these associations have also caused a number of theological controversies (Hart 1999:216).

As the revival movement progressed, the colonial church experienced controversy before the institution of the Adopting Act in 1729 by which the Westminster Confession and Catechisms were established as the official doctrinal statements of American Presbyterianism (Lingle & Kuykendall 1978:67). For instance the Synod of Philadelphia had already overcome three major problems in 1722. Firstly, the nature and authority of polity was debated. One group preferred a hierarchical system of congregations and the others did not. Secondly, adherence to the Westminster Confession was required of all clergymen as a guarantor of orthodoxy within the church, which had been disturbed by the arrival of unsound ministers from abroad. There were numerous complaints from the opponents of the requirement. Thirdly, the controversy over the preaching of Samuel Hemphill set the Presbyterians as a church against his latitudinarian opinions, thus uniting those who opposed adherence with the more traditional defenders of orthodoxy (Westerkamp 2000:3-4).

¹¹ Revivalism "means a concerted effort to win the unconverted to Christ and awaken believers from spiritual slumber" (Hart 1999:216).

As the American Presbyterians took root in the American colonies, they experienced significant spiritual awakening between the 1730s and the American Revolution¹², it was during this time that they built institutions and developed leadership (Smylie 1996:47). During the previous ten years of spiritual revitalization, the two parties had battled in the presbyteries and synods over the best ways to spread the gospel and serve the people (Westerkamp 2000:3). James H Smylie analysed this (1996:47) as follows:

Presbyterians had their hands full helping immigrants adjust to life. In their synod and presbyteries, they had to sort out tensions that grew from spiritual ferment and that led to what was called the New Side—Old Side division. They began to develop their own educational, mission, and charitable institutions, out of which grew remarkable indigenous leadership.

Even before the division of 1741 between New Side Presbyterians and Old Side Presbyterians, they had begun to build various institutions of education, missions, and charitable causes (Smylie 1996:49). During the first few decades of revival movements in the eighteenth century, three big problems emerged which related directly to ministerial qualifications, different understandings of genuine revival, and the nature of true faith (Westerkamp 2000:16). We will examine the three issues separately.

As conversions brought more people into the churches, the provision of adequate pastors became a major concern. Therefore William Tennent (1673-1746) began a school called the Log College in 1727 to train ministers (Lingle & Kuykendall 1978:68). Ordained by the General Synod of Ulster in Ireland in 1701, Tennent had immigrated to New York in 1718 and moved to Neshaminy, Pennsylvania in 1727 (Hardman 1994:58-59). Within his first year, he started the Log College as an informal and private institution (Westerkamp 2000:6). By the time the College closed some years before his death in 1746 about eighteen students had graduated from this institution (Loetscher 1978:66). Although he was proficient in the classical languages, he emphasized the personal experience of God to his sons and his students. The graduates of the Log College were to become enthusiastic supporters of the Great Awakening (Westerkamp 2000:6). The Tennents and their disciples believed that the essential requirement for ordination was an experiential knowledge of the love and mercy of God (:9).

When we investigate the 1741 breach between the Old Side and the New Side, we find that there

¹² "The overthrow of British supremacy in America by the War of Independence, 1775-81" (Brown 1993:66).

was one key person in the middle of the schism. That key person was Gilbert Tennent (1703-1764), the eldest son of William Tennent. Gilbert studied at Yale and received his Master of Arts degree in 1725. In the same year he was licensed by the presbytery of Philadelphia and in 1726 he assumed a pastorate in New Brunswick, New Jersey. In New Brunswick Gilbert met the Dutch Reformed minister, Theodore Jacob Frelinghuysen (Logan 1999:257). He was impressed by Frelinghuysen's evangelistic preaching and learned a great deal from his methods (Smylie 1996:48). Theodore Jacob Frelinghuysen (1692-1747) was born in Germany, studied at the University of Lingen in Holland from 1711 to 1717 when he was ordained. He was deeply influenced by Pietism¹³. He arrived in New York in January 1720 and started his work at the Dutch Reformed Church at Raritan, New Jersey (Hardman 1994:52-53). He emphasized the necessity of conversion and the resulting visible evidence of new spiritual life in professing Christians (Loetscher 1978:67). He has been recognised not only as a distinct source of the Great Awakening but also as the leader of an earlier revival throughout the Raritan Valley (Hardman 1994:59-60).

In 1729, the Freehold congregation which was ministered by John Tennent, William Tennent's second son, became the first New Jersey community to experience regeneration as a community, asserting that "regeneration is absolutely necessary in order to obtain eternal salvation" (Westerkamp 2000:5). During the following decade the Tennents and other Log College graduates began to experience the results of revival with great enthusiasm.

As the decade progressed, such phenomena occurred more frequently, until challenges were waged in presbyteries and carried to the synod. By 1738, many of the Log College men had organised themselves (or were set apart, it is a difficult call) into the new presbytery of New Brunswick. Throughout the next seven years, the New Brunswick presbytery would boast the most active preachers of the communion as they travelled huge distances as itinerants, organised new congregations, intruded into settled parishes, and generally, in their own terms, furthered the work of the gospel (Westerkamp 2000:7).

As the frontier community continually acquired immigrants from Ireland, Scotland, and England, the problem of too few ministers became worse and worse (Smylie 1996:47). Itinerancy was the only means by which they spread the gospel. In these poor circumstances the New Brunswick men were much heralded for their efforts. They also preached within the boundaries of other

¹³ "Pietism can be described as orthodox Christianity that emphasizes 'a heart warm toward God' rather than doctrine" (Hardman 1994:52).

presbyteries and congregations with settled ministers. The ministers of the settled areas were not happy when the New Brunswick preachers intruded among their own congregations. At the same time probationers with questionable qualifications who could not **find** a place in Scotland or Ireland migrated to America. The colonial congregations eagerly welcomed them but the probationers experienced many problems. The Synod decided that all probationers who had not finished their education in New England or a recognised European college would be **subject** to Synodical examination to test their basic academic knowledge. As the tensions increased between the New Brunswick presbytery and others in the Synod, students of William Tennent were not happy because the Log College was regarded as a private institution and therefore the graduates would be required to take an examination. In **1738**, the New Brunswick Synod decided to license Log College graduate John Rowland without this examination. **Rowland's** preaching at the congregation of Hopewell and Maidenhead, New Jersey, split the congregation (**Westerkamp 2000:7-8**). The presbytery of New Brunswick first ignored the resolution as not applicable to them and later protested against the **1738** act at the 1739 Synod. They defended themselves as a presbytery and strove to maintain their own authority in the field.

Gilbert Tennent raised the question of ministerial qualifications and as a result, transformed the concept of examination. He understood that academies were corrupt and that the church should encourage private schools under the governance of the experienced Christians (**Westerkamp 2000:10**). He asserted that the Presbyterian ministers did not know Christ. He censured the clergy by calling them Pharisee-teachers and dead dogs who were like the blind leading the blind (**Smylie 1996:48**). He called people fools for staying with unconverted ministers and encouraged people to leave their congregations to join other congregations. He even suggested that people leave good ministers who were evidently less capable. People misunderstood that they were therefore free to choose whosoever they pleased. This threatened the traditional Presbyterians' theology of vocational calling and ordination (**Westerkamp 2000:10**). **Tennent's** sermon provoked animosity between the Old Side and the New Side and contributed towards the division of 1741 (**Logan 1999:257**). In conclusion, the Old Side was convinced that the ministers should be educated in the fashion which had become traditional in the Universities of the Old World and New England. They focused on the importance of erudition as a qualification for the ministry. On the other hand, the New Side adherents asserted that experiential piety and an experiential knowledge was more important than academic ability for ministerial qualifications. They felt that the academic education was both slow and to some extent irrelevant, so they had begun to build schools for the education of ministers (**Lingle & Kuykendall 1978:68**). Jonathan

Dickinson succeeded to William **Tennent's** Log College by securing a charter from New Jersey to form a College in his home in Elizabethtown, New Jersey. This institution moved to Princeton in **1746**, where it became the College of New Jersey (Smylie 1996:50). Although it was not officially a continuation of the Log College, it did for some time perpetuate its spirit. After being briefly located in Elizabethtown and Newark, it moved to Princeton in **1756** and became Princeton University in **1896** (Loetscher 1978:67).

There is no doubt that the New Side and Old Side differed with regard to their understanding of revival. The first Presbyterian ministers in the American colonies were Scottish and Scotch-Irish ministers sent to the Presbyterian immigrants in Pennsylvania and Maryland. The scarcity of these ministers compelled the Presbyterians to accept Congregational clergy, principally from New England. "They differed from the immigrant ministers over the degree of adherence to the Westminster Confession of Faith." The New Englanders were deeply influenced by Continental Pietism and their own Puritan origins, believing that personal religious experience was more important than confessional subscription as the primary qualification for church membership and ordained ministry (Guelzo 1990:821). The New Side group made use of the revival to bring new souls to Christ. They awakened people to a sense of their own sins, not only in the privacy of their hearts, but in large, emotional, communal ceremonies of revivalism and piety. They claimed that the Holy Spirit had brought true transformations of individuals and communities through revival (Westerkamp 2000:4).

The intention of the Old Side Presbyterians was to organise Scottish and Scots-Irish immigrants along with Presbyterian-minded Puritans from New England under an authoritative Synodical government. They argued against the methodologies of the New Siders claiming them to be disorderly and contrary to Presbyterian principles. They criticised the New Side for using the psychology of revival and attacked the New **Siders'** association with George Whitefield who they believed was misleading people by his overemphasis on conversion (Guelzo 1999:182). The Old Side was opposed to revival because of the perceived emotionalism and potential disorder of the movement (Lingle & Kuykendall 1978:68). "Old Siders were disturbed by incidents of weeping, screaming, fainting, bodily commotions like '**epileptic fits**,' which indicated loss of control, accompanying some awakening preaching." They claimed that this kind of behaviour did not manifest the gracious work of God's Spirit (Smylie 1996:49).

On the other hand, the advocates of the New Side understood the essence of true faith to be **the-**

religion of the heart and were convinced the revivals to be the work of the Holy Spirit. They described their opponents as legalists (Westerkamp 2000:8). Jonathan Edwards (1703-1758) was a Congregational preacher and theologian (Edwards 1999:90). But his first pastoral work was done at a Presbyterian Church in New York before he served as a Congregationalist in Massachusetts, first in Northampton and later **Stockbridge** (Moorhead 2000:20). His influence on Presbyterians was great through his extensive preaching and writing on revivals. Even though formal ties did not exist, New Side Presbyterians selected him for leadership (Edwards 1999:90). He became President of the unofficially recognised Presbyterian College of New Jersey in 1758 only weeks before his death (Moorhead 2000:20). He shifted the focus of attention away from the head to the heart or the affections (Stout 1990a:816), while the Old Side found the essence of true faith in right reason and intelligent orthodoxy or the religion of the mind (Westerkamp 2000:8). They denied the Great Awakening as a work of God, claiming instead that it damaged the peace and unity of the church by sending "enthusiastic lay people and itinerant preachers against the established clergy of New England" (Stout 1990b:841). Francis Alison, John Thomson, and John Ewing were renowned leaders of the group (Guelzo 1999:182).

2.3.2 The **Old** School-New School Controversy

The schism of 1741 between the Old Side and New Side differed in essence from the schism of 1837 between the Old School and New School. The main cause of the former was revival while this was not the main factor of the breach of the latter. Nevertheless "the tension between the confessional and Pietist factions in the Presbyterian Church remained apparent and surfaced again in the New School-Old School schism of 1837" (Guelzo 1990:821). In the eighteenth century, the Congregational ministers who were largely from England refused to subscribe to all the doctrines of the Westminster Confession of Faith and Catechisms. Conversely, the Presbyterians who were mostly from Ireland and Scotland, were in favour of strict subscription to those standards (Lingle & Kuykendall 1978:67). New England Congregationalism and Scots—Irish Presbyterianism played an important role in the Old School-New School division of 1837 (Guelzo 1999:182).

It was apparent to all that there was a remarkable revival of religion during the last years of the eighteenth century which was called the Second Great Awakening. The revival movement certainly influenced the Presbyterians (Lingle & Kuykendall 1978:72). All at once the nation's westward expansion began with thousands of emigrants from the older settlements (Moorhead

2000:20). Walter L Lingle and John W Kuykendall (1978:72) explained the Plan of Union in their book *Presbyterians: Their history and beliefs*:

In 1801 the Presbyterian and Congregationalist Churches entered into an official policy of comity and cooperation in new areas of work, which was known as the Plan of Union. Ministers from each denomination would be accepted as pastors in congregations belonging to the other, and some congregations were allowed to hold a sort of joint membership in both denominations at the same time. The purpose of the plan, of course, was to enable both of these Reformed denominations to keep abreast of the needs for missionary work among the settlers in the rapidly growing area beyond the Appalachians. Thousands of people were emigrating from the older settlements along the Atlantic seaboard to "the West": Ohio, Indiana, Kentucky, Tennessee, and western New York. Neither denomination had a sufficient number of ministers to keep up with the explosion of new settlement by itself, so the two willingly joined hands.

Although the Plan of Union between Presbyterians and Congregationalists worked well, problems began to emerge that threatened the continuation of the cooperation. Some of the Congregational ministers annoyed Presbyterian Churches because of their different theological standpoint from the Presbyterians which they even preached in Presbyterian Churches. In addition to this theological disagreement, "there were numerous conflicts within the denomination over the best ways to organise, regulate, and finance the missionary effort." Once more, division developed within the American Presbyterian Church known as the Old School and the New School schism (Lingle & Kuykendall 1978:73). In the end the Old School majority voted to expel four predominantly New School Synods in the 1837 General Assembly. The Old and New School Presbyterians existed in separate denominations until 1870 (Moorhead 2000:19).

The two groups, New School and Old School, had the complicated history of cooperation and disagreement that had marked the relationship between Congregationalists and Presbyterians. Congregationalists, largely from England, settled initially in New England after 1630. Presbyterians, some of them from England but mainly from Ireland and Scotland, came to America in the eighteenth century and chiefly inhabited the middle colonies such as New York, New Jersey, Pennsylvania, and Delaware. Of course the two groups disagreed over polity. They also held on to the memory of religious struggles they had in England, Scotland, and Ireland that had previously made them sometime foes as well as allies (Moorhead 2000:19-20). The Old School supported a rigid adherence to the Calvinism of Westminster and a tight rule of all missionary activity by the denomination itself (Lingle & Kuykendall 1978:73). They were

doctrinally more conservative than the New School and had many adherents in the south (Smylie 1996:78-79) and who sought to avoid the controversy of the problem of slavery (Lingle & Kuykendall 1978:73). The New School did not have to subscribe to the Westminster Confession (Smylie 1996:79), and believed in a measure of theological latitude, favouring interdenominational cooperation in missions. They were also abolitionists and thus had most of their support in the north (Lingle & Kuykendall 1978:73-74). Theologically the Old School viewed the New **Schools'** theology with great suspicion and claimed that New Schoolers denied orthodox teachings about the total depravity of humanity and imputed righteousness of the redeemer as the sole ground of redemption (Moorhead 2000:30). The Old School preferred the division of the church along theological lines and governance rather than sectional lines (Smylie 1996:79). In the end the Old School majority abrogated the Plan of Union and expelled the New School at the General Assembly of 1837 (Moorhead 2000:30). "This division illustrates how difficult it was for Presbyterians to seek the peace and unity as well as the purity of the church" (Smylie 1996:80).

Even though the division of 1837 between the Old School and New School was not caused by revival itself, the revival of the Second Great Awakening did influence the schism indirectly, because the conflict between the two groups began on a full scale from the Plan of Union in 1801. In the main, the Plan of Union was created as a result of the Second Great Awakening.

2.4 The different concepts of revival within the American Presbyterian Mission as exemplified by a representative protagonist and a representative antagonist of John Sung's campaigns

The old categories of Old Side and New Side in the eighteenth century, or Old School and New School in the nineteenth century in American church history, do not have any direct connection with the Thai revival of 1938-1939 through John Sung's campaigns. It is generally accepted by the church historians that the distinction between Old School and New School had become more or less meaningless by 1870 (Swanson 2002) because the American Presbyterian Church came to tolerate the positions of both sides. Nevertheless we cannot deny that the tendency of the theological interpretation of the nature of genuine revival until 1870 in American Presbyterianism, lay behind the stance of the American Presbyterian missionaries in Thailand even in the 1930s. Unfortunately it is not possible to collect material regarding the theological conviction of individual missionaries concerning their understanding of revival. Furthermore it

is virtually impossible to fully understand the theology of revival of any specific missionary because such information is not available. However, the writer will attempt to analyse the different concepts of revival of a representative protagonist and a representative antagonist of John **Sung's** campaigns which has been gained from what material is extant.

It is known for instance that the Rev Loren S **Hanna** was the most ardent supporter of John **Sung's** campaigns among the American Presbyterian missionaries. On the other hand the Rev Carl Elder was reputed to be the most bitter antagonist of the campaigns. We will first analyse the Rev **Hanna's** understanding of revival. We shall then investigate the Thai revival of 1938-1939 in Chapter 5 and analyse and evaluate the revival in Chapter 6. Here, we will consider the theology of revival of the two missionaries respectively by using existing materials. It is quite remarkable that the tendency of the division of 1741 between Old Side and New Side Presbyterian in America exactly manifested the same pattern two-hundred years later in the Thai revival of 1938-1939. The three problems of the schism of 1741, namely, ministerial qualifications, different understanding of the nature of true revival, and the nature of true faith, once more **reoccurred** in Thailand. There was intensification in the Fundamentalist-Modernist controversy between Hanna and Elder during the revival in Thailand. We will observe the four problems one by one.

Firstly, the problem of ministerial qualifications.

John **Sung**, a Chinese evangelist, paid a visit to Thailand in September 1938 and had a six-week evangelistic campaign. His second trip was in May 1939 and set off two months of meetings. The campaigns brought about the biggest general spiritual awakening Thailand has yet experienced. After John **Sung's** meetings a confused state of affairs arose in the CCT because the campaigns led to people coming to repentance and faith, and backsliders were restored to faith again, leading to a rate of increase higher than any seen before. The communicant church membership increased in 1939-1940 just after the revival. The sudden increase of church members became a burden for the Thai church leaders and the missionaries who had to help them (**Pongudom** 1984:84).

John **Sung** led the last twelve days of evangelistic meetings in Bangkok in July 1939 after more than two months of continuous itinerant ministry. Night meetings took the form of normal evangelistic meetings but the day meetings consisted of Bible study (**Singhanetra** 1939a:165). On

the last day of the meetings that was on 2 August 1939, one hundred and sixty-six Christians signed and asked the APM to establish the Bible College. It is not clear whether the idea came from John Sung himself or from the Thai church leaders (Bible Conference Bangkok 1939) but it is certain that it was done without the missionaries' initiative (Bassett 1939). They requested that the Bible College be started within the building of the McGilvary Theological Seminary, the only official theological institution to produce ministers in the CCT. They also asked for the Rev Loren S Hanna, one of the most enthusiastic protagonists of John Sung's campaigns, to teach them the Bible (Seigle, A G 1939:163). In the end the Board of Directors of the McGilvary Seminary and the Rev Carl Elder who was the principal of the Seminary refused to accede to the suggestion of the group advocating the setting up of the Bible College (Elder 1939a). In any case, it changed into the conflict between Hanna and Elder.

In about 1923, long before John Sung visited Thailand Loren S Hanna ([s a]) evaluated evangelistic work in Thailand. He suggested the following regarding the development of the national work for the completion of the self-supporting church: to install a pastor with full authority; if there was no ordained man, an elder could be installed as assistant to the missionary-pastor and after a few years of training in this capacity, such a person may be fit for ordination; the missionary must make it publicly known that he is an assistant and not have authority over the pastor; the missionary may give the national workers advice but he could not have control over them. His recommendation was an epoch-making proposal at that time (Hanna [s a]:5-6). By contrast, Carl Elder had a traditional view of the qualifications of the minister. He (Elder 1940a) wrote a letter regarding the matter to his friends on 10 July 1940:

"It is highly injurious to the honor of the Church and to the teaching of the Gospel to have the ministry fall into the hands of ignorant and unlearned men." Moreover, the Presbyterian Church has never recognized the right of any excepts those in the ministerial office to examine and ordain others into the office. To speak in Episcopalian terms, "Only bishops can ordain bishops." This, I say, is the standard of our Presbyterian Church, and is the standard received and accepted by the Church in Thailand from us. I believe this standard, is right.

Carl Elder expected a very high standard of ministerial qualifications whereas Loren S Hanna wanted to lower the standard according to the situation in Thailand at that time. The Chiangmai First Church accepted as the pastor of the church Mr Bunmi Rungrueangwong who was never prepared as a full-time minister at the Seminary, instead of choosing Mr Suwan Chaiwan who had finished his studies at the McGilvary Theological Seminary under Carl Elder (Pongudom

1984:86-87). After this incident, Carl Elder complained that the decision of the church was in fact "the degradation of the sacred office of the ministry" (Elder 1940b). He also accepted the decision of the church as a direct blow to the standing of the Seminary (Elder 1940a).

Loren S Hanna considered that secular scholastic ability or qualifications were not essential for the minister who had more need of the knowledge of the Bible and the experience of the Holy Spirit. Conversely Carl Elder expected that ministers had to have theological education as well as a high scholarly attainment. Elder's position over the proper mode of education for the ministry was the same as that of the Old Side group namely, that ministers should be educated in the traditional Universities (Lingle & Kuykendall 1978:68). Hanna's perception of the qualification of the minister was similar to the New Side adherents' viewpoints that stressed experimental piety rather than erudition (Westerkamp 2000:6).

Secondly, there was a different understanding of revival.

The Rev Loren S Hanna (1939b) firmly believed that the Holy Spirit manifested his mighty power through John Sung's campaigns. He was thrilled to see the backsliders come back and join the church. There had been evidently a real change in the lives of the Christians. He was also deeply impressed by John Sung's prayer life and his preaching by the power of the Holy Spirit. Carl Elder (1940b) understood the revival totally different from Hanna. He claimed that John Sung used highly emotional methods in his preaching. The witness bands which John Sung started in the churches disturbed the perceived church order and did not fall under the control or the authority of the church. He was confrontational enough to evaluate the campaigns as of "the devil and so must be completely eradicated" (Cort 1940). Just as Old Siders were disturbed by weeping and loss of control of the New Siders in American Presbyterian Churches (Smylie 1996:49), in the same way Carl Elder was upset by the same phenomena which accompanied John Sung's campaigns.

Thirdly, the nature of true faith.

Carl Elder saw the followers of John Sung as unbalanced Christians (Eakin [s a]:1). Carl Elder's two co-workers of the McGilvary Theological Seminary, **Banchop Bansiddhi** and **Prasert Intaphantu**, wrote a letter to the Executive Secretary of the APM on 25 October 1939 stating that John Sung used psychological methods to persuade his hearers in his evangelistic meetings.

There is no doubt the two Thai co-workers of the Seminary were influenced by their leader, Carl Elder. Elder and his co-workers denied the revival as a work of God, claiming that it damaged the unity of the church. They understood that intellectual understanding of the Bible was the essence of true faith. Hanna had a balanced attitude toward the nature of true faith. Hanna ([s a]:7-9) emphasized intensive Bible study for the missionaries and national workers. He honored God's Word and stressed the importance of the Bible. He also took much account of the experience of the Holy Spirit (Hanna 1926:22-24). In conclusion, Hanna admitted the importance of the heart as well as intelligence as the essence of true faith. Generally speaking, the supporters of John Sung's campaigns were criticised by the other parties for a tendency toward emotionalism (Elder 1940b).

Lastly, we consider the Fundamentalist-Modernist controversy between Loren S Hanna and Carl Elder.

This controversy is not related to the Fundamentalist-Modernist controversy of American Presbyterianism in the 1920s. It concerns the relationship between Hanna and Elder only. After John Sung's second visit of 1939 in Thailand, Hanna raised questions about the theological orthodoxy of Elder. He was suspicious of Elder's liberal tendency in his theology and afraid that his theology might influence the ministerial candidates of the McGilvary Theological Seminary. Hanna (1939a) wrote a letter to Elder regarding two books that were assigned to a Thai student. He stated to Hanna, "you are headed directly for a terrible tragedy, and I will do anything I can to save you from it." He was convinced that the two books were of a liberal nature and that he was deliberately leading his students astray by liberal theology. Elder (1939c) complained that Hanna had discredited him and the McGilvary Theological Seminary by spreading a groundless rumor. Elder said "it is not a matter fundamentally of belief but of ethical practice." Elder did not admit his theological fault. He (1940b) in return criticised Hanna's wrong accusation that the Seminary did not teach the truth. But Paul Eakin (1939), the Executive Secretary of the APM, strongly recommended to Elder that the Fundamentalist-Modernist controversy between them should be kept out of the revival issue. It seems clear that Elder's theology may not have been as liberal as the Modernists in American Presbyterianism in 1920s. It seems safe also to assume that there is room for doubting Elder's theology as perceived from Hanna's fundamentalist viewpoint.

We can find a very interesting point here that although Hanna was a strong protagonist of revival he was nonetheless a fundamentalist. It would not be a mistake to suppose that even so, Elder

was one of a fervent anti-revival group but his theology was not conservative as was the Old Side or Old School American Presbyterians.

2.5 Summary and conclusion

In this chapter we briefly studied a history of the split within American Presbyterianism before the Second World War. Presbyterians mainly from Ireland and Scotland settled in the middle colonies and became the backbone of American Presbyterianism. Congregationalists who were largely from England settled in New England. According to American Presbyterians deeply rooted in the colonial frontier, they experienced the revival of religion.

When we studied the theological controversy about revival within American Presbyterianism, we came to the conclusion that Congregationalists generally favoured revival, but that Presbyterians generally resisted it. Ironically revival was the main reason for the schism of Old-New Side Presbyterianism of 1741. William Tennent and his son Gilbert Tennent were in the middle of the breach. They experienced three main problems, that is, regarding ministerial qualifications, different understanding of revival, and the nature of true faith. The two groups were reunited in 1758 but they broke off relations again in 1837. This time so called Old-New School Presbyterians had trouble with more complicated problems than the schism of Old-New Side of a century ago. Revival was one of the reasons of the division but was not the main factor. Old-New Schoolers reunited in 1869. American Presbyterians once again returned to the cycle of schism and reunion.

When we investigated the concepts of revival within the APM in Thailand in 1930s, we found that the same kind of obstacles, namely, ministerial qualifications, different understanding of revival, and different understanding of the nature of true faith became the main reasons of the conflict and became important issues in Thailand two centuries later. It is nearer to the truth to say that a remarkable resemblance existed between the schism of Old-New Side of 1741 in America and the Thai revival of 1938-1939. Between the Rev Loren S Hanna, a representative protagonist and the Rev Carl Elder, a representative antagonist, they had almost the same problems as American Presbyterianism even though these differed in certain respects.

It follows from what has been studied thus far that the American Presbyterian missionaries did not actually learn the lessons of history. They repeated the same mistakes that their forefathers

had made two-hundred years before in America. We hope **the** future Thai church and missionaries can learn a vital lesson from the past and that they will not make the same mistakes when **in** God's grace, future revivals occur.

Chapter 3. Three factors which impinged upon and affected the result of the revival in Thailand

3.1 Introduction

Thailand became known as one of the least fruitful countries in mission work. An American missionary, Budgett Meakin (1896:43), expressed his discouragement at his unfruitfulness in Thailand in 1896 thus: "I believe there is no country more open to unrestrained missionary effort than Siam, but I believe that there can hardly be a country in which it is harder to make an impression." He continued, "It is like bombarding an earthwork, one's shots are buried, and nothing is seen. It would be a relief even if one's hearer got mad about it." Samuel Kim (1980:vii) stated that despite the "heroic work by sacrificial missionaries and national Christians, the growth rate of the Thai Church is one of the slowest in the world. Thailand can be compared to wet firewood which does not easily burn."

In 2000, after 175 years of church history Protestant Christians comprises only 0.47% of the more than sixty million inhabitants (Johnstone, Mandryk & Johnstone 2001:619). Why is the gospel work at such a low ebb in Thailand? Also, what are the reasons that the Thai respond to the gospel so slowly? The writer would like to investigate some factors which have influenced the result of the gospel work in Thailand. These factors unquestionably exercised an influence over the results of the 1938-1939 Thai revival. Human beings do not exist in a vacuum. Charles L Chaney (1984:28) described the importance of cultural factors in communicating the gospel to a man as a social being:

It is impossible to communicate with him except through his own cultural channels...Our goal is not to tear down and destroy the structure of culture, but to seek an incarnation of Christ in each and every particular culture, to see the character and beauty of Jesus manifested in each distinct cultural world.

Not only do cultural elements but also historical, social, and religious factors play an important part in conveying the meaning of the gospel to the recipients. These same factors, have also helped to shape the Thai. So in a sense the people are both by-products of and governed by those factors.

By extension then, we may ask how much was John Sung's ministry directed from outside of the subculture of the church that was already there?

The specific focus of Chapter three is on the historical, **socio-cultural**, and religious factors which impacted upon the result of revival in Thailand. A **diachronic** approach will be used to investigate the factors. This is not a comprehensive explanation of the three factors, since the purpose here is to look at some facts which anticipated the context of the Thai revival of 1938-1939. The political, economic and religious situation which influenced the Thai church during the period of John Sung's campaigns will be portrayed. A synchronic approach will be used to analyse the conditions.

3.2 Historical factors

Thailand was known as **Siam**¹⁴ until June 1939 (Kim 1980:5). Thailand means *land of the free* because it has successfully retained its freedom since the thirteenth century whereas surrounding countries came to be ruled by Western powers. The constitutional monarchy, with the popular king, Bhumibol Adulyadej or Rama IX, had a strong unifying and stabilizing function. When we look at the present composition of the population we note that out of 61,399,249 people in 2000, 80.4% are Thai, 10.5% are Chinese, 3.8% are Malay, 3.4% are Mon-Khmer, 1.1% are Tibeto-Burman, 0.2% are Meo-Yao, and 0.6% comprise the other ethnic groups (Johnstone, Mandryk & Johnstone 2001:619). We will first investigate the prehistoric era of the Thai and then divide Thai history into four periods.

"The early history of the Siamese of prehistoric time has been vague and shadowy" (Dodd [1923]1996:275). Historians still do not know for certain how Thai people came to live in their current land, Rong **Syamananda** (1988:7) summarized that "the Thais originated in western or northwestern Szechuan 4500 or 5000 years ago." Due to Chinese aggression in their area, the Thai migrated south. Eventually they were scattered all over the area known as the Golden Triangle, from southern China to the Malay peninsula. Many groups of Thai joined together to form the Nan Chao Kingdom in order to withstand the Chinese (**Phuttharaksa** 1981:214). The Nan Chao Kingdom was conquered by Kublai Khan of China in 1253 and the wandering people went down to the extreme south of Southeast Asia. The people called the Shan or Thai Yai went

¹⁴ "For centuries the Thai have called their Kingdom Mueang Thai, i.e., Thailand...In modern times, the official name was Siam up to 1939 and again between 1945 and 1948" (Skinner 1957:vii).

westward to the Salween River of Burma and some of them migrated to the west and established the **Ahom** Kingdom in the Assam area of India. The group that migrated to the east stayed around the Mekong River, Tongking and Laos. Another group advanced along the Chao **Phraya** River were called Thai Noi and became the ancestors of the present Thai (Kim 2000:75).

Rong **Syamananda** (1988) divided Thai history into four periods, namely, the Sukhothai period (AD 1238-1438), the Ayutthaya period (AD 1350-1767), the Thonburi period (AD 1767-1782), and the **Ratanakosin** period (AD 1782-present time). We will look at a brief history of each period and certain legendary rulers whose fame and influence have continued up to this day.

3.2.1 The Sukhothai period (AD 1238-1438)

The first king of the Sukhothai Kingdom was King Sri Inratit. A further nine kings ruled for over 200 years, from AD 1238-1438 (Kim 2000:77). The dynasty that ruled Sukhothai Kingdom is known as the Pra **Ruang** dynasty (Syamananda 1988:21). King Sri Inratit was at first called Bang **Klang** Thaw. His kingdom was more powerful than the other smaller kingdoms of Thai so that he was able to unite the other minor kingdoms and to form one large kingdom of the Thai people. That kingdom was then able to take Sukhothai from the Cambodians (**Phuttharaksa** 1981:214). The Kingdom of Sukhothai covered a small area near the **Yom** River (Syamananda 1988:22). At the time of the third king, King Ramkhamhaeng, the Sukhothai Kingdom was the most prosperous in the kingdom (Kim 2000:77). "He was a valiant warrior, a wise man, a far-sighted scholar and a brilliant diplomat" (Syamananda 1988:22). In 1283 he invented the Thai alphabet, using as its basis the Mon and Khmer scripts which derived from a south Indian script (:26). He began relations with foreign countries, sent sailing vessels to China, and brought Chinese artisans, skilled in the production of glazed ceramics, to Thailand. The inscription on a stone pillar of King Ramkhamhaeng is the oldest first-hand source of evidence on Thai history. This inscription gave information about the Sukhothai Period. Thus under King Ramkhamhaeng the borders of Thailand expanded greatly, expanding southward as far as the tip of Malaysia, and he was able to control almost all of Laos and Cambodia as well (**Phuttharaksa** 1981:215). During his **rule**, the role of the king was characterised by the paternal relationship with his people (Syamananda 1988:24).

The Sukhothai Kingdom ebbed away after King Ramkhamhaeng. During his son, **Loethai's** reign most of the vassal states threw off their allegiance to the Sukhothai Kingdom and declared

themselves independent. The royal family suffered from internal dissension over succession to the throne. In 1378 the Sukhothai Kingdom surrendered to the Ayutthaya Kingdom when King **Thammaraja II** ruled. After King **Thammaraja IV**'s death the Sukhothai Kingdom was absorbed by the Ayutthaya Kingdom (Kim 2000:78).

3.2.2 The Ayutthaya period (AD 1350-1767)

There were thirty-three kings from five different dynasties which lasted 417 years during Ayutthaya period (Kim 2000:78). Ayutthaya perhaps marks the most prosperous period of Thai history (**Jumsai** 2000:84). "Ayutthaya was a thriving town before it was founded as the capital of Siam by King **Ramatibodi I** in 1350 and was already a trading centre" (**Syamananda** 1988:32). During **Ramatibodi**'s reign the government had the form of an absolute monarchy with strong Cambodian influences. The king became an autocrat and was regarded as the "Lord of Life." "The whole land in the country belonged to him and a court language grew up to designate anything concerning himself or his possessions" (**Syamananda** 1988:33). King **Ramatibodi I** laid the solid foundation for his successors (:34). He had distinguished himself as the prince of Utong (032).

King **Trailok**, the fifth king of Utong's line, is the most important king of this line (**Phuttharaksa** 1981:215-216). He is famous for establishing the military and civil administration (**Syamananda** 1988:37). The *Sakdinaa* or rank system was introduced by King **Trailok** to distribute certain amounts of land assigned to each class of people (**Phuttharaksa** 1981:216). The officials received no salaries but did obtain an income from the system of land tenure (**Syamananda** 1988:38).

The Ayutthaya Kingdom was attacked by the Burmese twenty-four times and the capital was taken twice (Kim 2000:82). "The first time the Thai lost the capital to the Burmese was in the reign of King **Chakkraphat** in the year 1563" (**Phuttharaksa** 1981:217). Queen **Suriyothai**, the wife of King **Chakkraphat**, and her two daughters disguised themselves as the men went out to the battle with Burmese. When the elephant of King **Chakkraphat** and the elephant of the Burmese general clashed head-on, the Thai elephant was in the losing position. Then Queen **Suriyothai** drove her elephant between them and received the sword blow herself instead of the king (**Phuttharaksa** 1981:219-220). She has been regarded as one of the greatest heroines of Thai history (**Syamananda** 1988:47). **Naresuan** was held hostage, at the age of nine, for seven years in Burma. When he became king he expelled the Burmese and enlarged the kingdom (Kim

2000:83). During the reign of King **Narai** the Ayutthaya Kingdom was at its peak. The kingdom collapsed at the hands of the Burmese in **1767** which was the most horrible blow to Thailand as most of her cultural treasures were lost (Syamananda 1988:91).

3.2.3 The Thonburi period (AD 1767-1782)

The Thonburi period has only one, ruler, that of King Taksin. After the capital was established in Thonburi, there were many wars with Chiangmai, the Cambodians and the Burmese. King Taksin had outstanding generals, Phya Mahakasatsak and his younger brother, to help him. While Phya Mahakasatsak was away fighting against Laos, the people began to think that King Taksin was mentally unbalanced. A group in Thonburi captured the king and put him to death. The Thonburi period came to an end (Phuttharaksa 1981:224).

3.2.4 The Ratanakosin period (AD 1782- present time)

When Phya Mahakasatsak heard the news, he returned to Thonburi and was able to bring the rebellion under control. The people made him king because of his ability to organise the situation (Phuttharaksa 1981:224). He was the first king of the Chakri Dynasty and was given the posthumous title of Rama I by his great-great-grandson in the 1920s (Syamananda 1988:100). Rama I (1782-1809) moved the capital from Thonburi to Bangkok, in Thai **Krung** Thep, in 1782. King Rama I is notable for his efforts to restore the glories of the Ayutthaya Kingdom. He tried to compile the Buddhist scriptures and all legal texts, and he revised numerous literary works. The king's son, King Rama II (1809-1824), succeeded to the throne. He was interested in poetry and the arts. "The Second Reign is generally considered to have been an interlude" (Terwiel 1991:46). King Rama III (1824-1851) was a stern and strong administrator. He has received relatively little attention from the historians for various reasons. During the final years of his reign economic stagnation was the problem facing the Thai government. His distrust of Europeans exacerbated the danger of outside intrusion (Terwiel 1991:47).

King Rama IV or King Mongkut (1851-1868) was called to the throne when he was forty-six years of age. He had spent twenty-seven years in the monkhood (Terwiel 1991:47). During that time "he studied Pali, Sanskrit, Cambodian, Mon, Singhalese, the histories of the Western nations, mathematics, Latin, science, the Bible and astrology" (Jumsai 2000:353). He encouraged contact with Europeans and accepted modern science. He also accommodated new

ideas from Europe and respected their customs (Terwiel 1991:47). King Rama V or King **Chulalongkorn** (1868-1910) succeeded to the throne (Jumsai 2000:387) and was called "The Greatly Beloved Sovereign." He freed the slaves and sent people to study abroad using his own personal funds in order to develop the country like other countries (Phuttharaksa 1981:225). King Chulalongkorn is, however, regarded as having been in his later years the most autocratic king in Thai history (Terwiel 1991:48).

Two of King **Chulalongkorn's** sons followed him to the throne, namely, Rama VI or Vajiravudh (1910-1925) and Rama VII or Prachathipok (1925-1935) (Terwiel 1991:48-49). King Rama VI was the founder of modern nationalism in Thailand (Vella & Vella 1978:xiii). He started the Wild Tiger Corps in order to build nationalism in 1910 (:27-28). He also introduced many European sports and changed the national flag (Terwiel 1991:49). He joined the Allies in the First World War in July 1917 in order to make the country better known abroad and to stimulate nationalism (Vella & Vella 1978:112). King Rama VI pursued the Buddhist nationalism movement. The king emphasized in 1914 that it was not natural for an Asian to become a Christian just as it is unnatural for a European to become a Buddhist. He was very emphatic about the importance of Buddhism as part of a national identity and said that conversion to Christianity was a sign of weakness, vacillation and opportunism (Hughes 1989:28). During King Rama VII's reign a coup d'etat broke out on 24 June 1932 (Terwiel 1991:49). The revolution led by the **People's** Party whose leading members were educated in Europe, changed the regime from an absolute monarchy to constitutional government (Syamananda 1988:162). Before the Japanese army entered Thailand in December 1941, Buddhist nationalism was strengthened. Government officials forced Christians to revert to Buddhism on the grounds of patriotism and political expediency (Hughes 1989:28). During King Rama VIII or **Ananda Mahidol** (1934-1946) the War of Greater East Asia broke out in December 1941 and was merged into the Second World War. The Thai government concluded an alliance with Japan and declared war against the U.S.A. and Great Britain (Syamananda 1988:173). Immediately after the War Thailand repudiated the declaration of war on the U.S.A. and U.K. (:175). In June 1946, King Rama VIII had been found dead in his bed and his younger brother King Bhumibol Adulyadej succeeded the throne as King Rama IX (1946-to the present) (Terwiel 1991:49-50). King Rama IX is the longest-living king in Thai history and is widely respected by the Thai (Kim 2000:53). "Although the king has very little real power in his own right in the structure of the constitutional monarchy, all power is still exercised in his name" (Kim 1985:10). At times of national crisis he solved the problems effectively (Terwiel 1991:50).

These historical factors helped create within the Thai psyche a national spirit of devotion and allegiance to royalty. While under the Edict of Religious Toleration—issued on 8 October 1878 by King Chulalongkorn (McGilvary 1912:207-215)—the very idea of acceptance of something as alien as another belief system would predictably find little response in the heart of an average Thai person.

3.3 Socio-cultural factors

Undoubtedly the socio-cultural elements exercise an influence upon the results of Christian witness in Thailand. We shall therefore investigate the unique characteristics of Thai personality and their understanding of and resistance to both Christianity and other European influences.

3.3.1 Characteristics of Thai personality

This section is concerned with understanding the Thai value systems and behavioral patterns which influenced the fruits of the gospel work. It is reasonable to assume that these elements are important in relation to the results of the Thai revival of 1938-1939. Many attempts have been made by foreign scholars to analyse Thai behaviours and social systems. It is difficult to find satisfactory research results despite their strenuous efforts. **Suntaree Komin** is a Thai Fulbright scholar who spent ten years researching the psychology of the Thai people. Her book, *Psychology of the Thai people: Values and behavioral patterns*, Komin (1991) offers nine value clusters which are characteristic of the Thai (Komin 1991:132-213). Her research is the first systematic study of the Thai value systems ever conducted in Thailand (:1). She is considered to be the foremost authority on the characteristics of Thai personality. After explaining seven different existing interpretations of Thai social systems and behavioural patterns (:3-16), she provides an important source to help us to understand the value system and characteristics of Thai personality. She defines values as "core conceptions of the desirable within individuals and society. They serve as standards or criteria to guide human thought and actions" (:26). The writer would like to use Komin's research results and to add his own experience as a missionary who engaged in church planting and Bible teaching.

By characteristics are meant the common national traits in the Thai culture. These are sometimes called Thai national traits even though not every person in the culture would display all the characteristic dimensions in the same order of importance (Komin 1991:132). Komin (1991:133) enumerated the nine value clusters of the Thai; Ego orientation, grateful relationship orientation, smooth interpersonal relationship orientation, flexibility and adjustment orientation, religio-psychical orientation, form over content orientation¹⁵, interdependence orientation, fun-pleasure orientation, and achievement-task orientation. Let us look at each of the eight value clusters only.

3.3.1.1 Ego orientation

The Thai are primarily ego oriented, and place the highest value on being independent or being oneself (*Pen tua khong tua eng*). Self esteem is also very highly valued (Komin 1991:133). Thai people have a powerful ego, a deep sense of independence, pride and dignity. The Thai have "a genius for independence" (Siam, a Presbyterian responsibility [s a]:1). The fact is well founded and can be illustrated, when we consider the Thai history of the twentieth century. When the First World War broke out in 1914, the Thai government declared itself neutral. In July 1917 the government entered the War on the side of the Allies who became victors in 1919, and they thus profited by the War (Syamananda 1988:151-152). During the Pacific War which merged with the Second World War in 1941, the government went over to Japan and as soon as the War was over it sided with the Allies. Thailand gave full play to her diplomatic skill and was also able to pursue her own interests after the War (Syamananda 1988:173-175).

A central trait is that the Thai cannot usually endure any attack on the ego or self. Usually tranquil, their emotions can be easily aroused, if the self or a close family member or friend like one's father or mother, is insulted (Komin 1991:133). **Kukrit Pramoj**, ex-prime minister of Thailand, testified that there are three institutions which the Thai highly respect, i.e., Buddhism, the king, and parents. They are highly insulted by any criticism of those three institutions (Beek 1983:163). The writer had a bitter experience touching the ego orientation of a Thai when doing church planting in Bangkok, Thailand in 1995. After he told a Thai Christian lady "you should choose between God and your father," she chose her father and renounced her faith. They do not permit foreigners to touch what they perceive to be their three fold self namely Buddhism, the

¹⁵ Suntaree Komin (1991:133) used the terminology of education and competence orientation. In fact she referred to "form" over "content" orientation.

king, and parents. In fact, the propagation of the gospel must needs have an influence on their ego but they do not want to be subjected to the influence of new things from outside, especially Christianity.

This apparent obsession with the ego is the key to various habits of the Thai, like face-saving, criticism-avoidance, and the *Krengjai* attitude which is more or less the desire to respect another's feelings and privacy (Komin 1991:135). The *Krengjai* concept affects the everyday interpersonal behaviour of the Thai. It means "to be considerate, to feel reluctant to impose upon another person, to take another person's feelings (and "ego") into account, or to take every measure not to cause discomfort or inconvenience to another person." *Krengjai* behaviour is followed by everyone regardless of rank and position, and operates in all relationships, even that of husband-wife, and close friends, differing only in degree. A Thai knows the extent to which his or her *Krengjai* can apply in each situation, status difference or relationship (: 136). The *Krengjai* concept becomes an obstacle to sharing the gospel with the Thai, because this attitude becomes a barrier to true dialogue and communication (Kim 1985:43). They do not like to be coerced by other people into doing something. The parents even feel reluctant to persuade their children to believe in God.

The face-saving value is a most important trait for the Thai. They keep the ego at all costs, even when their lives are in danger. Public confrontation is particularly shunned regardless of the status of the other person. A person must never be made to lose face, regardless of his or her rank (Komin 1991:135). Compromise becomes a necessary tool, therefore, so that face-saving can be accomplished and a superficial peace enjoyed (Mejudon 1997:54). This trait is often misunderstood by foreigners when they proclaim the gospel to the Thai. When missionaries or Thai Christians share the gospel, the Thai do not reject the gospel outwardly and even accept Jesus Christ as their personal saviour. In fact, in many cases the Thai accept the gospel because they do not want to cause the other person to lose face. At the same time they are very proud of their history in that they have never been colonised by a European power. They have retained their national pride as Thai people. Their attitudes towards maintaining their dignity concerning their religion, Buddhism, and their culture make it extremely difficult for them to accept Christianity.

3.3.1.2 Grateful relationship orientation

The Thai value sincere and deep relationships, the deepest being the *Bunghun* (goodness, favours, etc) relationship, a psychological as opposed to an etiquettical or transactional relationship. This indebted goodness is an emotional bond between two people who have given and received help with pure kindness and love, and who then experience a relationship defined by reciprocal gratitude and kindness. Reciprocity, particularly in terms of gratitude, is an important and characteristic trait in Thai society. The Thai have been taught to value this grateful (*Katanyuu*) quality in a person. A person should show gratitude to one who renders *Bunghun* to him, although this is not expected by the giver. Nevertheless the obligated person must be grateful and *Bunghun* must be returned, continuously and variously though never measured materially. It is ongoing and binding. The Thai, then, is brought up to value this process of reciprocity of goodness done, and continually reciprocated. Time and distance do not count (Komin 1991:139). In practice, *Saang Bunghun* (creating gratitude) is often used to make opportune or expedient connections (: 141). Nantachai Mejudhon (1997:55-56) analysed the phenomena thus:

This fact reveals why a missionary who taught science and English to a Thai king for only eighteen months, received numerous gifts and rights such as a place to teach Christianity in a Buddhist temple, lands, and the Edict of Religious Toleration in return. At the same time, this fact also reveals why missionaries who served as medical doctors and helped [to save] many Thai people from sickness and death could not convince them of the love of Christ.

Mejudhon continually said although missionaries may have contributed great *Bunghun* to the Thai, their superior attitude towards Buddhism and idol worship disturbed their strong ego. The Thai people saw the grateful relationship turning into a power dominated one.

When the Thai received help from missionaries, they experienced anguish of heart between the *Bunghun* of the missionary and the ego or self of the Thai. The *Bunghun* concept has also sometimes enabled the Thai to accept Christianity. Yet, when they think about the *Bunghun* which includes the indebted goodness of the parents, relatives, friends and colleagues at the work place who are mostly Buddhist, they are not easy to convert to Christianity. The Thai Christians feel the pressure all around them in that, if they receive the gospel, non-Christians see them as traitors to their own country. Generally speaking, Thai people think that to be a Thai is to be a Buddhist and that Buddhism is the religion of the Thai whereas Christianity is a religion of the Westerner. Wan Petchsongkram (1975:13) testified that even non-believers mistakenly believe that Thai Christians are enticed by money to engage with foreigners and foreign religions.

3.3.1.3 Smooth interpersonal relationship

This orientation is shown by their preference for people who are humble and polite and their need for gentle and tactful interaction. Indeed, foreigners are charmed by their affable and pleasant aspect (Komin 1991:143). The Buddhist influence is often cited as shaping certain Thai characteristics, such as *Jai yen* (calm and easy-going nature and not easily excited), *Maipen rai* (being contented and imperturbable), and *Arom dii* (ever-smiling, even-tempered, without extreme emotional expression). Such characteristics accord with the Buddhist teaching which discourages external expression of inner feelings. "Buddhism encourages self-control that maintain coolness regardless of circumstances" (Kim 1985:39). *Jai yen* and *Maipen rai* concept make the Thai cover up their real intention and abhor both extremes. The concept makes them conceal their real desire and expectation so that outsiders struggle to understand them. The tendency becomes an impediment to Christian witness.

Suntaree Komin (1991:159) claims that there is an obvious absence of strong prejudice against other religions, different beliefs or different races, because the Thai would rarely show a condescending attitude toward another human being. We do not take the position that her assertion is correct as we have shown in Chapter 3.2.4. On the surface the Thai do not reject different beliefs directly but they did virtually in Thai history.

These social values dictate that a person must take care not to hurt another person's feelings and not to criticise or reject another person's kind deeds, even though this may be contrary to one's own feelings (Komin 1991:145-146). Herbert P Phillips (1966:66) described this double-minded personality as "social cosmetic." Alex Smith (1977:75) commented that "face to face conflict is avoided, and feelings masked in diplomatic ways". Nantachai Mejudhon (1997:58-59) insists that these traits of the Thai are cultural features as well as the result of the long history of Buddhism. "This characteristic makes it extremely difficult to determine the sincerity of a person's attitude" (Kim 1985:40). From these characteristics of the Thai, they are not seriously concerned about their religious life (:41). At the same time that kind of mindset prevents the Christians from actively preaching Christ's message. In many cases, when missionaries are planting a church, some Thai people come to the church. But when the missionaries go back home nobody goes to church. The social smoothing values cause missionaries to misunderstand the Thais and think they are not trustworthy.

3.3.1.4 Flexibility and adjustment orientation

Obviously the Thai are flexible and situation-oriented (Komin 1991:161). There is nothing so serious as to be **unbendable** or unalterable for the Thai. Everyday use of the language of the Thai portrays the flexible characteristic of the Thai people. This flexibility value orientation is somehow correlated with not being rigorous in principle, and consequently reflects a "decision-shifting" behavioural pattern quite common for the Thai. They might even alter their principles (Komin 1991:164-165). Philip J Hughes (1989:45-46) gave a good example of this disregard for principles and doctrines among the Thai. He did research among Christian and Buddhist students who were studying at Payap University in Chinagmai, Thailand in 1981, investigating why they responded to the gospel. There were a few students who accepted the gospel because of its message of salvation and the forgiveness of sin. Forgiveness of sin was seventh out of ten reasons for becoming Christians among the Thai Christian students. In contrast, forgiveness of sin was the primary reason for the importance of Christianity among the missionaries in the CCT.

Sometimes they renounce their faith in God. "The Thai view missionaries themselves and what they do in various situations as more important in their conversion to Christianity than dogma or doctrines" (Mejudon 1997:60). One of the biggest frustrations of the missionaries and Christian workers in Thailand is not being able to see numerical growth in the Thai churches but being unable to see many strong Christians who are in the faith on the ground of sound biblical doctrines.

3.3.1.5 Religio-psychical orientation

Buddhists account for more than 90% of Thailand's population. Unquestionably the religion has exerted a strong influence on the people's everyday life. The Thai are constantly engaged in religious rituals which are performed all year round at home, at work, and in the community, on such occasions as merit-makings on one's birthday, the formation of a new company, opening of a new building, celebrations of anniversaries, etc., not to mention festivals, customs, and religious days (Komin 1991:171-172). While the Thai are outwardly deeply devout and seem to be practicing Buddhism in their lives, most of them have little real knowledge about it. In general, the Thai do not consciously try to reach nirvana, and neither do they clearly believe in reincarnation. The average Thai does not normally think of reaching ultimate enlightenment. Thai Buddhists do not take seriously "other-worldly" doctrines such as rebirth, nirvana, and to a

lesser extent, karma. They are more of a “this-worldly” orientation (Komin 1991:176). Their beliefs and behavioural patterns are very superstitious. In practice they believe in spirits, astrology, and magic. Psychology plays an important role in popular Buddhism. No correlation has been found between educational level and the practice of superstitious rituals, and even the Western educated Ph.D. scientists refuse to think through the scientific implications of their behaviour in times of crisis. They wear their charms and amulets when they travel, for example. Buddhism serves, therefore, as a psychological cushion rather than as a doctrinal belief system (Komin 1991:181-185).

Generally speaking, Thai Buddhists are not interested in the content of the gospel. The writer has experienced numerous cases in his evangelism that show more interest in worldly blessings than the world to come. They ask very often, "If I believe in Jesus Christ, can he give me money, good health and success now?" The lack of a deep spiritual awareness in the Thai Buddhists has contributed to their slow discovery of the truth in Christ. Indeed, most of the testimonies of the Thai Christians in the local churches are related to material prosperity more than to spiritual well-being.

3.3.1.6 Form over content orientation

Generally, **knowledge-for-knowledge's** sake is not considered important in the cognition of the Thai. Education has been treated more as a means of climbing up the social ladder than as an end value in itself. The Thai people give importance to form more than to content; that is, they embrace "form" over "content" values. **Suntaree Komin (1991:186)** found that when politicians acquire a degree, they celebrate this in parliament.

Since the Thai place highest value on the "ego" self, the "face", and social relations, these decorative external labels, degrees, decorations, etc, are important, for the possession of them would identify the owner with the respected class of the society.

The Thai make much of good form and appearance, and behaviour that emphasizes material possessions is evident at all levels of society (Komin 1991:188). **Nantachai Mejudhon (1997:62)** stated that the Thai are not interested in the content of **missionaries'** teaching but they would like to benefit from them in finding jobs, learning English, and enjoying a better life. For these

reasons they might consider being Christian. If being a Christian means to suffer affliction, they will not accept Christianity.

The "form" over "content" value may contribute towards producing nominal Christians rather than building up strong Christians who have personal fellowship with God.

3.3.1.7 Interdependence orientation

The interdependence orientation reflects the spirit of community collaboration, and in a sense the importance of co-existence and interdependence (Komin 1991:189). Cooperative behaviour in the community can be found especially in times of crisis, when a family falls ill, suffers a death, or has a wedding. They bind their relationship through reciprocal services, assistance and exchanges of food. This other-oriented community value of interdependence and mutual help promotes the value of co-existence (:190-191). In times of crisis this value has more relevance than the Western individualistic life style.

Conversely speaking, this value system may pressure the freedom of individuals in the society so that they have difficulty in choosing their own religions. They feel restrained by the norms of the society. To make matters worse the *Kreng jai* concept, to be considerate, to feel reluctant to force upon another person, to take much account of another person's feelings, or to take every measure not to cause discomfort for another person (Komin 1991:136) in Thai society aggravates the difficulty in changing from Buddhism to Christianity. In short, the interdependence orientation value can possibly be an obstacle to Christian witness in Thai society.

3.3.1.8 Fun and pleasure orientation

The Thai enjoy life with a happy carelessness, for they see life as something to be enjoyed not endured, and avoid anything that is not *Sanuk* (to have fun, to enjoy oneself and have a good time) (Komin 1991:191). An outcome of the *Sanuk* life style is *Saduak* (convenience) and *Sabai* (ease, comfort, satisfied) traits (Smith 1977:76). To a Thai life itself is one long relaxation and must never be taken too seriously. This approach to life naturally leads to a kind of happy temperament (Beek 1983:163). The fun-leisure aspect can be explained as resulting from the need to keep pleasant and smooth interpersonal interactions. Consequently, most Thai social relations are pleasant, light, hearted and humorous. Joyful behaviour can be observed in any Thai

party in their small talk and jokes. They are kind and generous and show sympathy towards other human beings, strangers and foreigners included (Komin 1991:192);

As a result of these related attitudes toward life, they do not want to suffer for the gospel. The fun and pleasure trait make it difficult for the Thai to be serious when they need to be serious. They lack soberness even during a funeral service. The gospel message needs to be taken seriously for it deals with eternal life. The superficial and light tendency of the Thai can also interfere with the ability to have a deep relationship with God.

3.3.2 Thai understanding and resistance to Christianity and European influences

These days Christianity has already become a minority religion in the West (Lee 2002:51). Nevertheless Christianity is still recognised as the religion of the Westerners for the Asians (Lee 2002:48). The truth is that Western society has become post-Christian society. Christianity is not the religion of the Westerners anymore. On the one hand the numbers of the Christians are declining, and on the other hand, Christianity is not the norm which controls the thinking of Westerners. Christianity is a **post-Western** religion, spread across the world (Lee 2002:49). Nevertheless, in one sense the problem of the **foreignness** of Christianity is the most serious obstacle to the mission in Thailand. The foreignness of the gospel for the Thai has caused them to give a wide berth to the gospel. Carl E Blanford (1975:84) explained the foreignness of Christianity in Thailand as follows:

Christianity has been introduced into Thailand by Westerners and is generally regarded as a "foreign religion." Its institutions are foreign. The architecture of its buildings is foreign. Its music is foreign. Its emphasis on individual conversion and the separation of its members from their original social relationships also cause people to regard it as foreign. This foreignness of Christianity as introduced and practiced in Thailand constitutes a difficult barrier for the present-day missionary to overcome.

Although Christianity is no longer identified with Western religion, the Thai church and missionaries are still the victims of this wrong presupposition today. The presumption was not moulded in one night. It is the fruit of the long mission history in Thailand. Let us observe the historical reasons for this in Thai history.

Thailand was the only country in Southeast Asia that allowed missionaries to come in and spread Christianity officially without driving them out during the whole period from the sixteenth century to the present (Lee 1996:1). The Thai's responses to European powers and to Christianity are intertwined. Therefore it is difficult to separate the two elements from time to time.

We can distinguish three periods in Thai history: from 1511 to 1828; 1828 to about 1938 and from about 1938 to the present. In brief, the missionaries depended upon the power of the West during the first period. During the second period they relied on Western civilisation. They made use of Thai Christians who had been compelled to follow the example of Western Christians for the last period. The first period is related to the spread of Roman Catholicism. The second and the third periods are connected with both Roman Catholic and Protestant mission (Lee 1996:68-69). Let us examine the Roman Catholic mission for the first period. Then we will study the second period which related with the Protestant mission only. We will view the third period, which related to John Sung's campaigns, separately in Chapter 3.5.

3.3.2.1 During the first period, from 1511 to 1828

The Roman Catholic mission of the first period is not unrelated to the second period of the Protestant mission. This is because the mission strategy of the Roman Catholic Church for the first period affected the Thai's understanding of the second period of the Protestant mission directly afterward. Here a brief summary will suffice.

The two Catholic countries, Portugal and Spain, became keen rivals in search of new lands and trading interests. They were eagerly assisted by missionaries engaged in the propagation of the religion also. By the Treaty of Tordesillas in 1494, the world was divided into the eastern hemisphere and the western hemisphere (Syamananda 1988:41). The eastern hemisphere became the Portuguese field, while the western hemisphere was reserved for the Spanish. Alfonso d'Albuquerque, the first Portuguese envoy, travelled by Chinese junk to Ayutthaya and was well received by King Ramatibodi II in 1511 (Syamananda 1988:42). In 1516, Duarte de Coelho concluded a treaty of friendship and commerce which was the first one between Siam and Portugal. The Portuguese agreed to supply Thailand with guns and ammunition and gained the right to reside and trade at many places in the Kingdom of Ayutthaya. Additionally they were granted permission to practice their religion (Syamananda 1988:43). In 1555, two Dominican

priests arrived. In 1607, the first Jesuits came to Thailand. Most Catholic mission work focused on the Portuguese and Christians of foreign origin rather than on Thai people. During the reign of King Narai (1656-1688) Constantine Phaulkon was a government minister. He tried to convert the king and in this attempt ignited a violent anti-foreign revolution. He was tortured and beheaded and Catholic priests were banished or imprisoned. The event became a hurdle for Protestant mission, too (Smith 1982:9). The missionaries misunderstood the willingness of Thai leaders to accept Christianity. In fact, they accepted missionaries and gave freedom of religion for diplomatic purposes of building up friendship with the missionaries, that is, foreigners who had power, in order to pursue their own security and political power. The Thai had Buddhism as their national religion and were content with their own religion (Lee 1996:84).

During this period the entry of Christianity had to depend on the power of the West, such as the power of trade, power of politics and the power of armed forces. Therefore the response of the local inhabitants was that Christianity represented the Western powers (Lee 1996:64). The Thai look on the Christian religion as belonging to foreigners, and on Buddhism as their own religion. During the first wave the Thai saw Christianity as representative of the Western powers, so those in positions of leadership in Thailand tried not to let Thai people believe in Christianity while at the same time accepting Western power and letting missionaries come to Thailand. All this was done to save themselves (Lee 1996:68-69). "The colonial enterprises and missionary work went hand in hand with each other" (Chaiwan 1985:245). Thai leaders were happy to welcome missionaries from the point of view of politics, not religion. Thai leaders did not look on Christianity as a religion but as something attached to politics and trade.

3.3.2.2 During the second period, from 1828 to about 1938

The second period covers the time from the beginning of the Protestant mission in Thailand in 1828 to about 1938. Thai understanding and resistance to European influences and Christianity are different from the first period. We shall examine the Protestant mission work, especially the work of the APM because most of the mission work was carried out by this mission. In brief, the missionaries depended upon the power of the West during the first period but during the second period they relied on Western civilisation.

The missionaries during this period had no direct connections with Western political power or trade. The missionaries' method of spreading Christianity was to teaching modern Western

knowledge by building schools, hospitals and printing-houses. During the second wave of propagation of Christianity, the response of the Thai was to obtain its benefits first. Even though the Thai people did not believe in Christianity, they did not **reject** it. The leaders opened the door to all the missionaries to come and spread the religion even more, because missionaries were **leading** the way already in Western education due to the state of world politics, and Western policy and thinking was willing to separate Christianity from the power of politics and trade, but stressed Western culture. So missionaries had to work hard as teachers, doctors, printers, social workers and other professions, but were not able to get Thai people to believe in the Christian faith as much as they ought to, even though they helped Thai society to develop. We could summarize this by saying, the missionaries did much work but had little results (Lee 1996:100). Let us look over Thai understanding and resistance to European influences and Christianity according to the time of each Thai king during the second period.

During King Rama III's reign (1824-1851) the Siamese knew that the British had gained a victory over the Burmese in February 1826, so that their attitude immediately changed (Wyatt 1984:169). In June 1826, a treaty of friendship and commerce between Siam and Britain was signed. They agreed that Siam would not interfere with British trade in the Malay States, while Britain accepted Kedah, Kelantan and Trengganu as being under her suzerainty. Then in 1828 permission was given for two Protestant missionaries, Jacob Tomlin who was an Englishman and Carl Gutzlaff who was a German, to come in to do Protestant evangelistic work with the Chinese in Thailand (Syamananda 1988:115). Much suspicion was aroused when they talked of religion to everyone indiscriminately. King Rama III and many people in Bangkok thought they were merely spies from England (Breazeale [s a]:3). They distributed Chinese tracts when they worked among the Chinese. "They were thus suspected of being spies sent to organise the Chinese community to assist an English attack." An edict was issued prohibiting anyone to accept the tracts from the missionaries (Breazeale [s a]:4). Because of European expansion the king was suspicious of foreigners and kept missionaries under strict surveillance (Smith 1982:22). The United States entered into treaty relations with Siam for the first time in the Far East in March 1833 (Syamananda 1988:116).

The most important medical missionary and a remarkable physician, Dr Dan Beach Bradley, arrived in Bangkok in 1835 and worked for thirty-eight years until he died in 1873 (Syamananda 1988:23). "As preacher, teacher, physician, author, diplomat, translator, printer and colporteur, his record is one of untiring devotion" (:25). The Thai appreciated the kindness and practical

assistance that he demonstrated through his works, technology, science, and lifestyle. He was successful in all these works, but when he preached the gospel to the Thai he failed. “[T]he internal organs of the Thai responded to Western medicines immediately, but the internal worldview of the Thai turned against spiritual medicines” (Mejudon 1997:36-37). King Rama III was conservative and traditional (Smith 1982:22). At the end of his life, the king said to Phraya Si Suriyawong about the future of Siam (Wyatt 1984:180):

[T]here will be no more wars with Vietnam and Burma. We will have them only with the West. Take care, and do not lose any opportunities to them. Anything that they propose should be held up to close scrutiny before accepting it: Do not blindly trust them.

These things help us to see that the king saw missionaries in the first wave of propagation of Christianity as being inseparable from Christianity and Western power. Siam did not have to grant the foreigners any special rights or privileges (Syamananda 1988:117).

King Rama IV or King Mongkut (1851-1868) built the foundation for the stability of Thailand in the modern era by a policy of opening up the country to missionaries, as a tool for developing the country (Wyatt 1984:176). The policy of making adjustments to the Western powers by accepting Western developments was deliberately begun by King Rama IV in the 1850s (Vella & Vella 1978:xiv). He used the missionaries as an important instrument for communication and building relationships with the West. He studied the Pali language in order to read the original Buddhist Scriptures (Wyatt 1984:176). He learned English from American missionaries, studied Latin with Roman Catholic Bishop and specialized in astronomy and astrology (Syamananda 1988:119). The king entered into a treaty with Britain in 1855. The British were given religious freedom (Syamananda 1988:120). He also concluded treaties with America and France in 1856, with Denmark and Portugal in 1858, with the Netherlands in 1860, with Sweden, Norway, Belgium, and Italy in 1868 (Syamananda 1988:121). He was not an enemy of Christianity but would not accept it. He knew that as long as the king still believed in Buddhism, the majority of Thai people would not accept Christianity. So he opened the door to missionaries because he wanted to escape the threat of the Western powers, but at the same time he supported Buddhism to make it stronger in order to protect Thai culture (Lee 1996:130). King Rama IV admitted that Christian teaching had helped him to weed out his own superstition (Chaiwan 1985:260-261).

During the reign of King Rama V or King **Chulalongkorn** (1868-1910), "Siam was saved from the dangers that threatened her by two factors" (**Panikkar 1970:172**). The first factor was that Britain determined not to have a common boundary with France therefore Siam was maintained as buffer state. The second factor was the wisdom, tact and ability of the king who was wise in overcoming all the complicated diplomacy situations (**Panikkar 1970:173**). He travelled widely to all the colonial states (**Mejudon 1997:34**) and Western countries to learn their sources of strength. He did much to modernise Siam by building railways, telegraphs, telephones, reforming the coinage, establishing a modern postal system, etc. (**Panikkar 1970:173**). He accepted Western culture and scientific knowledge that did not conflict with the customs and culture of Buddhism. The king affirmed the truth and correctness of Buddhist moral principles which were real and pure. Even though close to missionaries and granting freedom of religion, the king did these things to develop the country in the core beliefs of Buddhism, and passed on these guidelines to the new generation through educational establishments (**Lee 1996:131**). "He believed that it was necessary to adopt western techniques in order to preserve Siam's political independence, its society, its essential culture" (**Vella & Vella 1978:xiv**).

King Rama VI or Vajiravudh (1910-1925) was indeed the founder of modern nationalism in Siam (**Vella & Vella 1978:xiii**). "If the nineteenth century has earned the name in history of the era of nationalism, the opening twentieth century may be designated the era of imperialism" (**Kohn [1932] 1969:49**). Nationalism derives from the belief that one's own ethnic or national tradition is especially precious and needs to be protected at any price through creation or extension of its own nation or state (**Hastings 1999:4**). Nationalism attempts to unite the members of one nation, politically and territorially. Imperialism inflames the nationalism of the oppressed peoples. "Thus imperialism and nationalism are interlocked" (**Kohn [1932] 1969:49**). Nationalism "arises chiefly where and when a particular ethnicity or nation feels itself threatened in regard to its own proper character, extent or importance, either by external attack or by the state system of which it has hitherto formed part" (**Hastings 1999:4**). Nationalism in Asia and Africa, it is now generally agreed, is the natural consequence of European exploitation of these areas which goes by the name of Imperialism, in other words, it is a reaction against European domination (**Kedourie 1970:1**). Religion has produced the dominant character of some nationalism (**Hastings 1999:4**). Nationality is not decided by language alone but also by religion (**Kedourie 1970:197**). Nevertheless we cannot deny that language is the basis of social life and the foundation of culture and civilisation (**Kedourie 1970:202**). "As language plays a part in

deciding religious affiliation, so religion plays a part in determining membership in a nationality" (Kedourie 1970:200).

Buddhism played an important role in the nationalism of King Rama VI while he was more anti-Christian than King Rama V (Mejudon 1997:28). He was a paradoxical blend of traditional autocrat and modern nationalist (Vella & Vella 1978:xiv). He was the first Siamese king to have been educated abroad and travelled widely. He received special military training with several British infantry units and studied history and law at Oxford (Vella & Vella 1978:2). He established the Wild Tiger Corps in 1911 to build nationalism for the task of defending the country which was patterned after European nationalism (Vella & Vella 1978:27-31). He fostered a spirit of nationalism which involved devotion to nation, religion, and king and was inspired by the British idea of God, king, and Country (Vella & Vella 1978:33). He also focused more attention on the monarchy than ever with the intention of building national unity (Vella & Vella 1978:77). He coerced the people by saying that anyone who was not ready to sacrifice his life for the king, country, and his religion leave his motherland (Vella & Vella 1978:91). He was a genius of diplomacy. At the start of the First World War, Siam was neutral. But when Germany was clearly losing (Vella & Vella 1978:107-108) he joined the Allies in the First World War in July 1917 to make the country better known abroad and to stimulate nationalism (Vella & Vella 1978:111). In 1919, Siam attended the Peace Conference of Versailles as one of the victors, gained their point, and revised all kinds of unfair treaties through skilful negotiations with other countries (Syamananda 1988:152-158). He also utilised the occasion for stimulating nationalism (Vella & Vella 1978:112). He not only used the West as model (:126-175) but also focused on developing historiography, Buddhism, and traditional arts for nationalism (:202-242). He utilised the media to the fullest extent such as direct speeches, plays, essays, letters, poems, songs, films, various celebrations, campaigns, and royal visits (:244). King Rama VI said that religion and nation are inseparable. He also emphasized that if a Thai became a Christian he or she won the favour of no one except the missionaries. He effectively persuaded the Thai to become Buddhists (:221). He modernised Siam along Western lines and planned to enhance national prosperity and defence by using models from the past and the West. He stressed that to be a Thai was to be a Buddhist. He made the best use of Western civilisation and Christianity to develop his country and retain Buddhism.

During the reign of King Rama VII or Prachathipok (1925-1935) Thailand ushered in the new

era of a constitutional monarchy instead of an absolute monarchy by a coup d'etat on 24 June 1932 of the People's Party which consisted of fifteen members, most of whom had been were educated in Europe (Syamananda 1988:162). The king was weak by nature and did not occupy an important position (:159). He pursued Rama V in politics and religion, but still kept to a nationalism that held firmly onto Buddhism (Lee 1996:133).

Rev C G Callender who returned to Siam from Yunnan for a few months' work in Thailand before retiring in 1937, wrote a personal letter stating that (Class III. Force list (Siam Mission) [s a]:2) "[t]he comparatively great success of the other two departments of mission work, the medical and the educational, seems to be running very efficiently." When we analyse the statistics of the APM for the year ending on 31 March 1939, we note the distribution of the national worker's forces. Among a total of 436 workers 79 nationals (18.1%) were hired for evangelistic work, 268 (61.5%) for educational work, 85 (19.5%) for the medical work, and 4 (0.9%) for work of other. Only about 18% of the nationals were employed for evangelistic work whereas about 82% of them were hired for educational, medical and other work (Eakin & Mitrakul 1940:62). The APM had 37 schools with 5,509 students (Eakin & Mitrakul 1940:64) and at the same time operated 9 hospitals, 10 dispensaries, and 38 itinerant clinics in Thailand (Eakin & Mitrakul 1940:65). From these statistics we discover the reason why the APM was applauded by the Thai people. It is no exaggeration to say that the American Presbyterian missionaries played a very significant role in the field of education and medicine. They identified Western civilisation with the propagation of the gospel. Thai leaders made use of the benefits of Western science via the missionaries for developing nationalism and Buddhism. The missionaries worked hard but their work bore little fruit.

3.4 Religious factors

"Thailand must be counted as one of the pre-eminent Buddhist countries in the world" (Keys 1987:416). According to the 1998 census there are 265,956 monks, 87,695 novices and 30,678 temples in Thailand (Kusalasaya 2001:3). Buddhists comprised 92.34% of the total population of 60 million in 2000 (Johnstone, Mandryk, & Johnstone 2001:618).

"Is there any shortcut to propagate the gospel to the Thai?" is one of the most frequent questions to the missionaries in Thailand. In his book *Poles apart?* John R Davis (1993:9) further expressed the frustration in communicating the gospel as follows:

Anyone who has spent time in Thailand attempting to communicate the "Good News" must come up against the exasperating fact, that no matter how brilliant a linguist one may be, how sincere in presenting the Gospel, how totally saturated in the local culture, one's message seems to fall on deaf ears.

A more elaborate example can be found in his book (Davis 1993:10-11). There was an enthusiastic young missionary who memorized Jn 3:16 with perfect Thai pronunciation for sharing the gospel with a Thai Buddhist. When the missionary communicated the gospel through the Bible verse to the Thai Buddhist, he heard the meaning of the verse according to the Buddhist point of view. There was an unmistakable lack of communication to the recipient which went unnoticed by the new missionary.

The Thai are saturated with Thai Buddhism from childhood. The influence of Buddhism sinks deeply into their minds long before they hear the Christian message. Even though a Christian witness might eagerly try to explain the dissimilarity between Christianity and Buddhism, most Thai Buddhists would respond, "Oh! The two religions are the same." This was a writer's experience as a gospel messenger in Thailand. Why do they misinterpret the content of the Bible message in this way? It is commonly agreed that the sophisticated philosophical belief system of Buddhism is the main reason that the Thai Buddhists misconstrue the substance of the Christian message. It demands the scrupulous study of Buddhism before we transmit the gospel to them. It is our conviction that Thai Buddhism has caused the Thai to distort the meaning of the gospel. It seems safe to assume that Thai Buddhism had a general influence on the result of John Sung's campaigns in Thailand. Therefore it would be valuable to consider the introduction to Buddhism before tracing the history of Thai Buddhism.

3.4.1 Introduction to Buddhism

We cannot deny that Buddhism is one of the world's major religions (Palmer et al 2002:110). Siddhartha Gautama, the founder of Buddhism, lived in India from 563 to 483 BC (Prebish 1988:669). He was the son of the king of the tribe of the Sakyas in present-day Nepal (Palmer et al 2002:100). At the age of approximately twenty-nine, he had an encounter with the aging, the sick, and the dying which changed his life. He decided to find the truth through meditation and

the ascetic way of life (Wagner 2001:25). At the age of thirty-five, he experienced Nirvana which means awakening or enlightenment (Palmer et al 2002:101).

The precepts of the Buddha are the three fundamental principles, the four noble truths, the eight-fold path, and the moral code. The three fundamental principles comprise the **impermanence** of all existence (*annica*), the inborn sorrow in everything (*dukkha*), and the non-reality principle of soul or self that is immortal (*anatta*). The four noble truths stated that all life is suffering, suffering originates with desire or excessive craving (*tanha*), there will be cessation of suffering, and nirvana can be attained by following the eight-fold path. The eight-fold path consists of right understanding, right thought, right speech, right action, right livelihood, right effort, right mindfulness, and right concentration (Landon 1939:224-225; Mole 1973:28-33; Wagner 2001:29-30). There are five moral precepts for everyone, three more are added for nuns, and two more are added for novices (Landon 1939:29).

As soon as the Buddha¹⁶ died at the age of eighty in 483 BC (Davis 1997:23), the first conference was held at Rajagaha (:29-31). The second council of Vesali was held in 383 BC (Davis 1997:31-32) and the third council of Pataliputta was held in 253 BC (Davis 1997:32-34). In its early history four major forms of Buddhism developed (Wagner 2001:27). Theravada or Hinayana¹⁷ Buddhism that claimed to follow 'the Teaching of the Elders' and was called 'the Lesser Vehicle' (Davis 1997:37). The adherents of this Southern school of Buddhism which maintain the Pali Canon, known as the *Tripitaka* (:53), can be found in Sri Lanka, Myanmar, Thailand, Laos, and Cambodia (Zürcher 1962:31). Theravada Buddhism claims to be most original and the oldest form of Buddhism (Wagner 2001:27), severe, strict, conservative and offering salvation to only a few. Theravada Buddhism accounts for about 150 million adherents (Smith 2001:9). Mahayana Buddhism which was known as 'member of great community' or 'the Greater Vehicle' (Davis 1997:37) is found in Tibet, China, Mongolia, Vietnam, Korea, and Japan (Palmer et al 2002:106). There are approximately 850 million Mahayana Buddhists all over the world (Smith 2001:9). The Northern school of Buddhism which uses Sanskrit Scriptures (Davis 1997:61), called *Sutras* (:59), is a less strict and rigorous system than the Theravada system and salvation is open to all (:37).

¹⁶ The term Buddha is a descriptive title meaning 'Awakened One' or 'Enlightened One' (Harvey 1991:1). We will use this term instead of the name of the founder of Buddhism.

¹⁷ The literal meaning of Hinayana is small or lesser career or vehicle of salvation (Humphreys [1962]1976:88). This term of reproach has been coined by the Mahayanists. The meaning of Theravada is 'the Doctrine of the Elders.' For the Theravada Buddhists this term, Theravada, is more accurate and less discourteous for them (:197). We will use this terminology rather than Hinayana from now on.

Vajrayana or Tibetan Buddhism (Davis 1997:40) has become better known in the West due to the influence of the Dalai Lama. This type of Buddhism focuses on mysterious practices (Palmer et al 2002:107) and the occult (Davis 1997:40). There are about 16 million followers (Smith 2001:9) in Tibet, **Sikkim**, Bhutan, Mongolia, Japan, Korea and China (Wagner 2001:28). Zen Buddhism which emphasizes extensive meditation in order to reach enlightenment was improved in China during the sixth century AD (:29). When Zen which is the Japanese form of the Chinese **Ch'an** reached Japan where it became more organised (Palmer et al 2002:108). Zen Buddhism had an impact on all aspects of Japanese life such as calligraphy, painting, the tea ceremony, flower arranging and music (: 109).

3.4.2 A brief history of Buddhism in Thailand

The history of Buddhism spans nearly 2,500 years from its origin in India (Harvey 1991:1). Buddhism has used a variety of teachings through time. The teachings of Siddhartha Gautama were handed down by the Theravada school which encapsulates the ancient or primordial path of the Buddha. On the other hand, the Mahayana school is distinguished by devotion to a number of holy saviour beings, expanded by several sophisticated philosophies including the basic doctrines from the earlier teachings (Harvey 1991:2). Buddhism came to Southeast Asia via the missionary movement of King Asoka who was an emperor Magadha in India (Kromamun Bidyalabh 1965:1) between 270 and 230 BC (Humphreys [1962]1976:36). King **Asoka's** brother, Mahinda (Davis 1997:34), and the monks, Sona and **Uttara** (Kromamun Bidyalabh 1965:1), introduced Buddhism to the Sri Lankan king, **Devanampiya** Tissa. Because of increasing pressure from Islamic forces the centre of Theravada Buddhism had moved from India to **Ceylon**¹⁸ by the seventh century AD (Davis 1997:34). However, a detailed history of the propagation of the Theravada and Mahayana Buddhism will be omitted on account of limited space.

About the first century BC, the Mahayana movement arose in southern India (Zürcher 1962:32). The Thai who lived in the Kingdom of **Nanchao** in south China (Kromamun Bidyalabh 1965:3) adopted Mahayana Buddhism which had already pervaded China from India (Syamananda 1988:25). "From the sparse and ambiguous records it can be determined that Buddhism came to what is now Thailand from India and Ceylon." Despite the fact that the Thai people had

¹⁸ "Former name of Sri Lanka" (Brown 1993:366).

interacted with Mahayana Buddhism, they did not adhere to its teachings (Deininger 1991:11). In the middle of the twelfth century AD, King **Parakrama** Bahu brought about a revival of Theravada Buddhism in Ceylon or Lanka. A delegation of Mon, Thai and Khmer monks went to Ceylon to study the recently revised Buddhist Scripture. When the Thai monk came back to his native land, he preached Lanka Buddhism at **Nakhonsithammarat** in south Thailand. When King Ramkamhaeng of the Kingdom of Sukhothai visited that city, he accepted the teachings of the Ceylonese school, namely Theravada Buddhism (Syamananda 1988:25). After the Kingdom of Sukhothai became independent from Khmer which had followed Mahayana Buddhism (Syamananda 1988:22), King Ramkamhaeng accepted Theravada Buddhism in order to eradicate the influence of Khmer (Kim 2000:132). The king adopted Theravada Buddhism as the state religion (Davis 1997:36). Sukhothai kings fully supported Theravada Buddhism (Lorgunpai 1995:174).

Throughout more than four centuries which marked the age of the Ayutthaya Kingdom (1350-1767), Theravada Buddhism was expressed not so much as doctrine or philosophy but rather in rites and ceremonies (Gustafson 1970:30). At the same time, the Ayutthaya Kingdom showed strong **Brahmanic** influences in court traditions from Angkor (Cambodia) especially after the fifteenth century (Keys 1987:417). This Hinduism travelled from India to Cambodia and then to Thailand especially to the Kingdom of Ayutthaya (Tambiah 1970:252). The Kingdom of Ayutthaya depended on a Brahman priesthood to conduct the royal rituals of installation and coronation including first ploughing, the sowing ceremony and top-knot cutting (Tambiah 1970:253). The Buddhism in Thailand thus came from India to Ceylon and thence to Thailand whereas the Hinduism in Thailand moved from India to Cambodia and thence to Thailand (Tambiah 1970:252). "King **Chulalongkorn** (1868-1910) restored many Brahmanic state rites in an effort to enhance the image of monarchy" (Keys 1987:417). The conception of kingship was borrowed from Hindu ideas (Tambiah 1970:252). On account of the decline of Buddhism in Ceylon near the end of the age of Ayutthaya Kingdom during the reign of King Boromkot (1733-1758), King **Kirtisri** (1747-1781) of Ceylon asked for a Thai delegation of Buddhist monks. King Boromkot complied by sending a batch of Buddhist monks. The Siamese Sect of Buddhism is still a major sect in that country (Kusalasaya 2001:21).

Theravada Buddhism has flourished without hindrance from the beginning of the Chakri Dynasty of the **Ratanakosin** period until now (Shin 1990:30). During the reign of King **Ramatibodi** or Rama I (1782-1809), the first king of the Chakri Dynasty of the Ratanakosin

period (Syamananda 1988:100), started a literary renaissance after the destruction of Ayutthaya (Syamananda 1988:105). He tried to reform the Buddhist order, *sangha*¹⁹ He set out a code of morality through which the conduct of the clergy as well as his lay subjects was standardized. This supported the administration which upheld the power of the ecclesiastical authorities (Kromamun Bidyalabh 1965:23-24). In the first two years of his reign he had issued seven of a series of ten royal decrees that aimed to clear the clergy of moral depravity (:24). He also financed the completion of *Tripitaka*²⁰ of the Buddhist Pali Canon. In 1788, a council was summoned to revise and collate whatever texts could be found in Siam or the neighbouring countries. This revision consisted of forty-five volumes each comprising an average of 500 octavo pages (:22).

Mongkut became King Rama IV (1851-1868) after having spent twenty-seven years as a Buddhist monk. He outdid his predecessor in the support of Buddhism (Syamananda 1988:107). While he was a Buddhist monk, he had a restless and inquiring mind. He was disquieted by the Buddhism he found in Bangkok. Even though he studied meditation to enhance his concentration, he was not satisfied with that (Wyatt 1984:175). Therefore he began seriously to study the Pali language in order to learn the original Buddhist Scriptures. When he had an oral examination in 1826, he demonstrated not only great linguistic facility but also considerable knowledge of the religious text. He plunged himself not into high ecclesiastical office like other royal princes but into the textual study of the core of Buddhist teachings and the original practices of the religion. In the end he was dissatisfied with the current state of Buddhism in Siam. He met the chief monk of the Mon sect in Siam and became convinced of the validity of the rigorous Mon discipline. In 1833, he founded *Thammayutika Nikaya*²¹ the "Order Adhering to the Dhamma"²², which are the teachings of the Buddha. He referred to *Maha Nikaya*, the older order which had been sustained in Thailand for a long time, as the "Order of Long-Standing Habit" (Wyatt 1984:176). "It became adopted by the new intelligentsia." The sect spread to Cambodia and Laos too (Kromamun Bidyalabh 1965:32). The older one contains far more monks than the new one, the ratio between the numbers of monks of the two sects being 35 to 1 (Kusalasaya 2001:25).

¹⁹ "The monastic order founded by the Buddha, the member of which are called *Bhikkhus*(m) or *Bhikkhunis*(f)" (Humphreys [1962]1976:167).

²⁰ "*Tripitaka*s interpreted as 'The Three Baskets' because the original documents were written on palm leaf and were kept in three baskets. Each basket contained different elements of teaching" (Davis 1997:53).

²¹ *Nikaya* means religious orders. Sometimes *nikai* has the same meaning (Kirsch 1981:148).

²² *Dhamma* is the Pali form. The Sanskrit form is *Dharma* (Humphreys [1962]1976:65). That means natural law which including moral law. "A word that occurs in many ways in Buddhism but with the primary meanings of doctrine, righteousness, condition, phenomenon. The sense of that which is ultimate underlies all its uses" (Petchsongkram 1975:207).

The development of a reformist Buddhist tradition that embodied Rama IV's ideals brought about further changes in the monastic order through his son, King Rama V or King Chulalongkorn (1868-1910) (Swearer 1987: 396). Another son of King **Mongkut**, Prince **Wachirayan**, was given effective authority over the whole monastic order during the reign of King Chulalongkorn. The religious reforms instituted by the prince became the basis for the officially sanctioned orthodoxy in contemporary Thai Buddhism (Keys 1987:418). At the same time King Rama V initiated policies that pursued the incorporation of all Buddhists within Thailand into a single national organisation. As a result of monastic discipline, a standard monastic curriculum, and the quality of monastic education improved throughout Thailand. Moreover two Buddhist academies for higher studies were launched in Bangkok (Swearer 1987: 396).

"Since 1932, successive governments have made use of a unified *sangha* and a statewide system of compulsory education to inculcate in the populace the idea that Thai nationalism is rooted in what is taken to be a common Buddhist heritage." Both the reformation of Buddhism and the emergence of Thai Buddhist nationalism served to enhance a self-consciousness in many Thai about their religion (Keys 1987:418). A new scripturalism in the area of text and doctrine has emerged by the new redaction of the *Tripitaka* in connection with the general Buddhist council held in Burma in 1956 and 1957. Doctrinal reinterpretation has followed in three areas, that is, an emphasis on the ethical dimensions of the tradition, a rejection of magical elements of popular thought and practice, and a rationalization of Buddhist thought in terms of Western scientific methods. Buddhist apologists have attempted to demonstrate that Buddhism is more scientific than other religions, particularly Christianity (Swearer 1987: 396). "All the Thai kings in the recorded history of present-day Thailand have been followers of Buddhism. The country's Constitution specifies that the king of Thailand must be a Buddhist and the Upholder of Buddhism" (Kusalasaya 2001:22). Historically, Thai kings played important roles in protecting and promoting Buddhism. Buddhism was identified with nationalism in order to strengthen national identity and protect the country from Western colonial powers as we have seen in Chapter 3.3.2 and will see in Chapter 3.5. The **every-day** life of a Thai from the cradle to the grave together with other elements of his or her life are based upon and moulded by this one common factor, that is to say, the spirit of Buddhism.

3.4.3 Characteristics of Thai Buddhism

Alex G Smith (2001:9) stated emphatically that “[t]ruly there is little pure Buddhism on earth, except among some dedicated intellectual Buddhists and long-term committed priests.” There are about a billion Buddhists, but many of them would be classified as folk Buddhists (Smith 2001:8). "Thai Buddhism as it is lived and practiced is actually a conglomeration of many religions and beliefs. It is a syncretistic mix that is flexible, accommodating and dynamic" (DeNeui 2002:3). Even though the average Thai would say that to be a Thai is to be a Buddhist (Marks & Mewhinney 1981:36), Thai Buddhism is neither pure nor orthodox Buddhism. "Thai folk religion is modified Animism, combining spirit cults, **Brahmanism**, and Buddhism into one integrated composite whole" (Smith 1977:78). As A T Kirsch (1981:147) has pointed out, the three basic **subsystems**—**Theravada** Buddhism, **Brahmanism** and **Animism**—of Thai religion are "functionally specialized so that they mutually support each other and rarely conflict." Despite the obvious inconsistencies among the three religious systems, the Thai view their syncretistic composition as one integrated whole (Smith 1977:92). Samuel Kim (1980:16) has also asserted that all sorts of religious and superstitious factors can harmoniously amalgamate in the syncretistic environment of the Thai society. Thus it seems that the Thai understand that there is no necessity for segregating any religion, and the more religions mix together, the more effective they will be in pursuing salvation. We must, then, study Thai folk Buddhism²³ or village Buddhism. Let us examine separately Animism, Brahmanism and Thai Theravada Buddhism.

3.4.3.1 Animism

Animism is not only the religion of tribal societies but is also prevalent in every continent and is part of every culture (Rheenen 1991:11). "Animistic practices have existed since long before Bible times. Animism flourished in the days of the early church and many of the believers came from an Animistic tradition" (DeNeui 2002:23). Gailyn V Rheenen (1991:20) defined Animism as follows:

[T]he belief that personal spiritual beings and impersonal spiritual forces have power over human affairs and, consequently, that human beings must discover what beings and forces are influencing them in order to determine future action and, frequently, to manipulate their power.

²³ The combination of Theravada Buddhism, Animistic practices, and Brahmanistic beliefs can be labelled Thai Folk Buddhism (DeNeui 2002:6).

The Thai adapted themselves to Animism before they ever heard of Buddhism or Brahmanism (Landon 1939:237).

Animist ceremonies and beliefs have a tendency to solve primarily **this-worldly** problems and concerns. They may also fulfill certain political and economic functions as well. The Animist subsystem seems to indicate a high degree of uncertainty, irrationality and capriciousness. Nowadays the influence of the Animist specialist is viewed with much scepticism "[a]s a guide to action, or a cure for ills, the Animist sub-system is generally a last resort." The principal Animist religious specialist tends to be a woman called *moo phii*²⁴ who is the spirit doctor (Kirsch 1981:153). The spirit doctor is chosen by some spirit. Once selected by a certain spirit, the person must become a *moo* or die. Sometimes *moo phii* do not want the role and actively fight against it until it is impossible to resist. The participants of the Animist subsystem tend to be of the client type. For the most part Animistic ceremonies tend to be private and are performed according to the demands of each individual situation. However, some ceremonies have public functions as well. They also tend to be highly localised (Kirsch 1981:154).

The spiritual beings of Thai Animism can be divided into two kinds viz., *phii*, and *phra khryang*. The *phii* spirits embrace a wide range of meanings (Smith 1977:78). There are both benevolent and malevolent *phii* (:79). The *phii* of ancestors are called *phii banphaburutor phii puyatayai*. The Thai believe that the souls of the ancestors become *phii* and look after the well-being of their descendents for the time being. The central Thai people perform ancestral sacrifices through the Buddhist system while on the other hand the northern Thai build spirit houses for the ancestors and make sacrifices of chickens and pigs every year. The property spirits called *san phra phumm cao thii* are found everywhere across Thailand (Kim 2000:155). The Thai build the spirit houses on the top of city buildings, in house compounds, and even in Buddhist temple grounds. They are invoked for safe journeys, and in family disasters of all kinds. "Offerings of flowers, incense, and sometimes food or figurines are made to those spirits." The guardian spirits of prominent men of the past are called *cao pau* such as the founder of a city or a province, or a pious monk. Some spirits guard sections of roads and the surrounding districts. Very often drivers of the cars honk their horns at them as they pass (Smith 1977:79). The Thai also believe in the spirits of nature (Kim 2000:156). "Spirits are believed to be in certain trees, rivers, mountains and other nature phenomena (Smith 1977:80). The most feared malevolent *phii* are the spirits of persons

²⁴ Sometimes this is spelt *phi* (Davis 1993:35).

who meet sudden or violent death, or die in childbirth because they believe that these spirits cause injury to people (Kim 2000:156).

There are numerous kinds of supernatural objects known as *phra khryang*. Many of these objects are sacralized which means they are purported to be infused with supernatural power by the magical manipulation of priests or other worthy people. When Alex G Smith (1977:80) surveyed the different types of images and objects with a Thai, he noted that there are powerful sacred objects (*khong khryang*) like the images of Buddha which are kept on worship shelves in the house or office called *phra bucha tang to*. Another group consists of small objects which are kept on the body of the person. The meaning of *phra* is "the honorific title of power used for the king, the Buddha, his images, the priests, and certain supernatural objects." There are cloth materials which are magically sacralized by Buddhist priests in order to infuse special powers into them (Smith 1977:81). Holy strings (*daajsai sin*) are mainly used for protection on different occasions: they are tied around the wrists of sick children; wound around the heads of the bride and groom in the marriage ceremony; placed on the coffin and strung around the funeral pyre; tied around the top of the first post of a house under construction; and used in the blessing of the household ceremony (Smith 1977:83). In addition to these holy strings, the tattoo (*sak*) involves a sacred incantation which is used to invoke supernatural power and it is used by both villagers and special practitioners. Holy water (*nam mon*) is used by priests and spirit practitioners for healing exorcism, and at Buddhist festivals (Smith 1977:83-84).

3.4.3.2 Brahmanism

Alex G Smith (1977:84) depicted the process of the introduction into Thailand of Brahmanism:

When the Thai immigrated southward from China they had extensive contact with the Brahman religion prevalent among the Khmers. During the Ayuthaya²⁵ period the Thai defeated the Khmers and brought some of the leading people back as captives to Thailand. Teachers among them introduced Brahman concepts to the Thai.

Brahmanism developed alongside with Buddhism in Thai history. Since King Mongkut or King Rama IV started *Thammayutika* *Nikaya* in order to eliminate the superstitious elements in Thai Buddhism, it attempted to exclude the mystical components of Brahmanism in Buddhism. Also,

²⁵ Normally the name of Ayutthaya is used in English.

the number of Brahman priests decreased after the revolution of 1932 (Kim 2000:145). Nowadays most of the Brahman priests are under the control of the royal family of Thailand (:146).

The structure and function of Brahmanism in Thailand is quite different from that of the Brahmanism in India. The Brahmanism in Thailand is composed of two elements: one associated with the royal court which can be referred to as "court Brahmanism" and "folk Brahmanism" that can be found widely diffused among the whole population (Kirsch 1981:150). A T Kirsch (: 150-151) explained the function of court Brahmanism thus:

A number of "brahmanistic" rituals were adopted specifically around the person of the King, as well as a number of rituals which symbolized the government's concern for and control over the rest of the society, e.g. rituals of "divine-kingship," the "first-plowing" ceremony, etc. Many of these rituals have been retained to the present. This addition of court brahmanism had important influences on the rationalization of political control, and the extension of the limits of the kingdom.

As we can see from the above, Brahmanism in Thailand contributed towards the strengthening of the monarchy and the concept of the divine rights of kings.

The goals of folk Brahman religious ritual can be characterised as **this-worldly**. The ceremonies are occasioned by illness, travel, marriage, and special occasions in the year or life cycle when requests are made for good health, long life, some special favour or some specific knowledge of the future on which to base a course of action (Kirsch 1981:151). The folk Brahmanism also has a political element like court Brahmanism. The key concept of folk Brahmanism is that of the *khwan* or soul, and the key religious ritual revolves around the *baisii*, a ceremony of "well-wishing" involving "tying the *khwan* to the body" (*su khwan*). This ritual is habitually performed for any well-known visitor who is to be honoured by the village. "On these occasions, the Brahman religious specialist (*moo su khwan*) can be seen as performing a politico-religious function." Folk Brahman ceremonies are usually private. There are a number of religious specialists who tend to be males in folk Brahmanism. The *moo su khwan* ("soul-tying doctor") and the *moo duu* ("looking doctor," i.e. fortune-teller, astrologer) are important. Frequently they are persons of some reputation in the village, honoured for their expertise. Monks may also perform some of the functions of Brahman specialists (: 152).

Ruth-Inge Heinze (1982:17) explained the *khwan* of human beings:

Insubstantial and indestructible by nature, the *khwan* is supposed to reside in a physical body, which it can leave during sleep, illness, or death. Without a *khwan* a person would not be complete. As a child grows, its *khwan* will also become stronger and more attached to its body.

The Thai understand that there are thirty-two *khwan* to a person. Celebrating the essence of life is called *thamkhwan* ceremonies. There is no standard practice and these ceremonies vary from one family to another (Heinze 1982:xvi). The ceremony is performed for a four-day old child and for a one month-old child (Kim 2000:157). For an adult, *tham khwan* ceremonies are performed before and after a long journey and when participating in a war, after a long sickness, and when changing one's social status. The ceremonies can be extended to apply to domestic animals, grain, house, and vehicles that are closely connected man (Kim 2000:158).

3.4.3.3 Theravada Buddhism

We have studied the route of the introduction of Thai Buddhism in Chapter 3.4.2. Now let us go on to sketch certain key characteristics of Thai Buddhism. For the purpose we will bypass any extensive explanation of its philosophy and analyse instead the monastic life of the religious specialists who are monks and novices and the life of lay followers.

The *Sangha*, the Buddhist monastic order, is very important to Buddhists whether monks or laity. For it constitutes the third part of the Three Jewels of Buddhism²⁶. "The *Sangha* are composed of *bhikkhus* (*bhikkus-sangha*, assembly of monks), *bhikkhunis* (nuns) and *savakas* (disciples), and *samaneras* (male novices) and *samanevis* (female novices) (Shin 1990:79). The most important Buddhist religious specialist is the monk. The different religious specialists may be distinguished on the basis of age and sex, and the number of religious precepts which they are expected to follow is graded (Kirsch 1981:148). A monk, for example, follows 227 precepts, a novice ten (Davis 1997:125) and the nuns eight (Kim 2000:140). A T Kirsch (1981:149) continues thus:

It is important to note that the most significant and respected Buddhist religious roles are in the hands of males. All Buddhist religious specialists are set off from the rest of the population by

²⁶ The first is Buddha and the second is *dhamma*(Shin 1990:79).

special clothing, shaved heads, dietary regulations, and special domiciles. The separation of the monk from the general run of mankind is so extreme that he is not counted as a "person" (*khon*) but is reckoned as falling into a class of "mana-filled objects" (*ong*) which includes Buddha image and royalty.

The Thai call the monks as *phra* which is a title of high power. They are treated as asexual like a kind of third person. They also play an important role in the social and religious events of the village or area (Smith 1977:91). Entrance criteria are defined by age, sex, health, and education, etc. Entrance into the monkhood is entirely voluntary and involves some formal training. The monks are free to leave their roles at any time. All men are encouraged to spend some time as a monk in the Buddhist temple (*wat*) (Kirsch 1981:149). Generally this is socially accepted as a pre-requisite for adulthood in Thai society. Nowadays some of the young men go into the monkhood for only three to seven days. Many young men enter the monastery at the beginning of the Buddhist lent (*wan khaw phansa*) (Kim 2000:139). Sons entering the monastery bring considerable merit to their mothers. Entering service to the priesthood (*buad naak*) is an important occasion for a family and community solidarity (Smith 1977:91). The monks not only follow an ascetic regime, learning Pali, Buddhist scriptures, praying, meditating, and improving their own personal salvation positions but also practice folk medicine, fortune telling, certain crafts and other tasks (Kirsch 1981:149).

In a wider sense, lay followers also consist of groups of the *sangha* including *upasakas* (male lay devotees) and *upasikas* (female lay devotees). They are closely connected with the monastic life even though they do not expect to attain nirvana, because the monastic life of the monks depends on the support of lay followers (Shin 1990:92).

We will now investigate the characteristics of the normal lay followers in Thai Buddhism. The layman is obliged to keep five precepts but, particularly on holy days, the devout laity may voluntarily follow eight precepts (Kirsch 1981:148). The five precepts for normal laities are: do not destroy life; do not defraud; do not commit adultery; do not deceive; do not take intoxicants. Three more are added for nuns: do not eat solid food after noon; do not dance, sing, or attend plays; do not use ornaments, perfumes, or oils. Two more are added for novices: do not sleep on a high bed; do not accept gold or silver (Landon 1939:225).

The Thai term for nirvana²⁷ is *nippan*, the state that signifies "release from the limitations of existence" (Humphreys [1962]1976:138). "Nirvana for the Buddhist is described not as a place, but as a state of being, or perhaps a state of non-being" (Davis 1993:77). Nirvana is "the state that one enters upon breaking out of the cycle of rebirth" (Johnson [s a]:11). Generally speaking the Thai do not deliberately try to reach nirvana (Komin 1991:176).

The essential concern of all Thai religious activity is the individual's attainment of merit (*bun*). The aim is to accumulate as much merit and reduce as much demerit (*baab*) as possible (Smith 1977:89). Alan R Johnson ([s a]:11) analysed the reality of the Thai Buddhist:

The majority of the practitioners can be considered *karmatic* Buddhists for whom the essence of their religious practice is the collecting of good merit in order to be reborn into a better state in the future. Here the focus is not so much upon the actual practice of Buddhism as adherence to the ritual elements of making merit. For these people the goal of liberation from their karma²⁸ to reach Nirvana is too difficult and impractical with all the demands of daily life. The goal of improving their karma through making merit via a variety of means becomes the core of their practice. This is the orientation of the folk Buddhist, mixing both Buddhist and Animistic practice without any sense of incompatibility.

Thai Buddhists do not take seriously other-worldly doctrines such as rebirth and karma (Komin 1991:176). The Thai are continuously engaged in merit-making (*tham bun*), and numerous other religious ceremonies (Komin 1991:171) in order to improve their fate both in this life and the next (Johnson [s a]:12). The lay followers of Thai Buddhism do not have a real hope in rebirth, nirvana, karma, and other-worldly doctrines but their belief helps to reduce psychological pressures only (Komin 1991:176-177). Thus Alan R Johnson ([s a]:13) writes as follows:

In a practical sense, people are interested in bettering their present lives or succeeding ones by the collection of merit and the avoidance of demerit (*baab*). The other-worldly aspects of true Buddhism, though expressed through Buddhist ritual and understood at least to a degree by the general populace, tend to be pursued only by those who are older and who have the time to expend in religious pursuits. Those who have families and jobs can only concern themselves peripherally with the gaining of merit through ritual means.

²⁷ Nirvana is the Sanskrit form whereas Nibbana is the Pali form (Humphreys [1962]1976:138).

²⁸ Karma in Sanskrit and *kammā* in Pali is the law of causality in the ethical sphere. It transmits both the good and bad of the past and present. "Thus according to karma, there is nothing which can stop or turn aside a particular fate once it has been set in motion" (Mole 1973:36).

Apparently the doctrines of Thai Buddhism are used by the lay Thai Buddhists as psychological consolation or a mental buffer.

The temple (*wat*) is the heart of the Thai community and the focus of many social and religious functions. The temple still plays a dominant role in the life of the Thai as a centre for worship, a community chest, a counselling agency, town hall, and sports playground (Smith 1977:90). In his book, *Thai Buddhism: its rites and activities* Kenneth E Wells (1960:85-134) gave examples of ten kinds of ceremonies which are temple-centred. If people do not participate in the communal religious ceremonies, they will be alienated. There are formidable community-centred activities which brush individualism away (Kim 1980:15). A T Kirsch (1981:157) summarized the three subsystems, Theravada Buddhism, Brahmanism and Animism which reciprocally amalgamated each other without conflict as in Table 3.

Table 3. Summary of the Three Religious Sub-System of Thai Religion

		Buddhism	Brahmanism	Animism
I.	Goal-Orientation	Other Worldly	This Worldly	This Worldly
	World-View	Rational-certain	Rational-certain	Capricious-uncertain
	Ritual	Standard-routine	Standard-routine	Individually-tailored
II.	Specialist	Predominantly male	Predominantly male	Predominantly female
	Recruitment	Universalistic achievement	Universalistic achievement	Particularistic ascription
III.	Participants	Laity	Client	Client
	Involvement	Constant	Intermittent	Intermittent
IV.	Attitudes Toward	Highly favorable	Favorable	Ambivalent
	Social Focus	Whole society	Bridging locality and society	Highly localized

Source: (Kirsch 1981:157)

3.4.4 Western world-view and Thai religious world-view

"A world-view is a set of presuppositions or assumptions which are held, consciously or subconsciously, about the basic make-up of the world around us" (Davis 1993:31). Paul G Hiebert ([1994] 2002:38) defines world-views as "the most fundamental and encompassing views of reality shared by a people in a culture." He continually states that people recognise the world differently because they make different assumptions about reality (1988:45).

John R Davis (1993:13) explains the dependence of Third World theologies²⁹ on Western theologies:

The fact is that the Third World churches are still saddled with Western theological systems, which in large measure confine and restrict their theological categories to Western presuppositions, and which in themselves are archaic and to some extent redundant even in the West.

"Western theologies are the products of the histories, cultures and realities of the West." Consequently they cannot adequately express the existential realities of Thailand (Yung 1997:2). The foreignness of Christianity is the most challenging hindrance for Christian witness in Thailand. Christianity has become known as in Thai *satsana farang* which means foreigner's religion. Insofar as the Thai recognise Christianity as the religion for the white, the Christian religion will remain a minority religion in Thailand in the future. Therefore we need to realise the limitations of Western theologies in Thailand.

Hwa Yung (1997:3) argues that the dissatisfaction with Western theology stems from the fact that it has been heavily influenced by the world-view of the Enlightenment. In his book, *Christianity with power: Your worldview and your experience of the supernatural*, Charles H Kraft (1989:27-34) explains the characteristics of Western world-view which was profoundly prejudiced by the Enlightenment. He analyses the Western world-view as naturalistic, which disregards the supernatural world; as dominated by materialistic values; as humanistic society which focuses on human accomplishments and abilities and where science takes the place of religion; as rationalistic in that all explanations are based on human logic and reason; and as valuing individualism and independence above community. Hwa Yung (1997:3) constantly

30

argues that Western theologies cannot understand the concerns of Two-Thirds World cultures which are much more holistic. The Thai culture does not distinguish sharply between the natural and the supernatural with its emphasis on the world of spirits. Therefore Western theology and Christianity are limited with regard to the genuine indigenization of the gospel in Thailand.

²⁹ Theologies that have emerged from area designated as the "third world" (McKim 1996:283). Third World "refers to those nations primarily in Africa, Asia, Latin America, and the Pacific which emerged from the colonial era after World War II" (McConnell 2000:955).

³⁰ "Synonym for terms such as "Third World," "Non-Western World," and "The South." It is intended to avoid any connotation of "third-rare" and instead to point to the poverty and size of the Third World" (Roxborough 2000:975).

Paul G Hiebert ([1994] 2002:196) used the term "the flaw of the excluded middle" which expelled the middle level of supernatural beings. He used a figure to explain the middle zone which Western science too often neglects.

Figure 2. **Western** Two-Tiered View of Reality

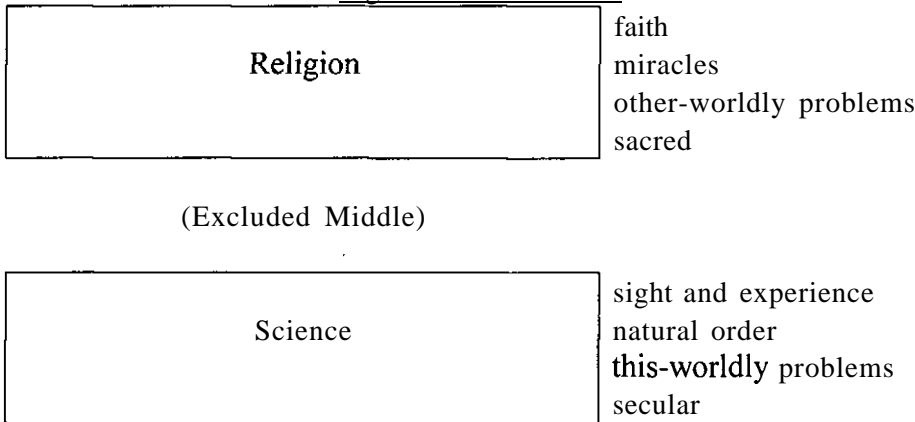

Source: (Hiebert [1994] 2002:196)

In Figure 2, the excluded the middle level of our perception of supernatural beings began to die in the seventeenth century and eighteenth century with the acceptance of a science based on materialistic naturalism. The outcome was the secularisation of science and the mystification of religion. Science regarded the empirical world in terms of mechanistic analogies but religion perceived other-worldly matter in terms of organic analogies (Hiebert [1994] 2002:196-197). Elmer S Miller (1981:70) designated the Western missionary "purveyor of a naturalistic world view as opposed to a **supernaturalistic** one." In the Western culture, the questions of accidents, misfortunes, and other unexplained events are left unanswered. When the Western missionaries went to the mission field of the Two-Thirds World cultures, they could not help the people to handle the crises and misfortunes of daily life (Hiebert [1994] 2002:197-198).

Paul G Hiebert proposed a holistic theology in order to deal with all areas of life both physical and spiritual in Figure 3. The highest level includes a theology of God in cosmic history since human history has meaning within a cosmic framework. The middle level includes a theology of God in human history. "This must include a theology of divine guidance, provision, and healing; a theology of ancestors, spirits, and invisible powers of this world; and a theology of suffering, misfortune, and death" (Hiebert [1994] 2002:198). The bottom level includes an awareness of God in his role of sustaining the natural order of things in natural history (Hiebert [1994] 2002:199).

Figure 3. A Holistic Theology

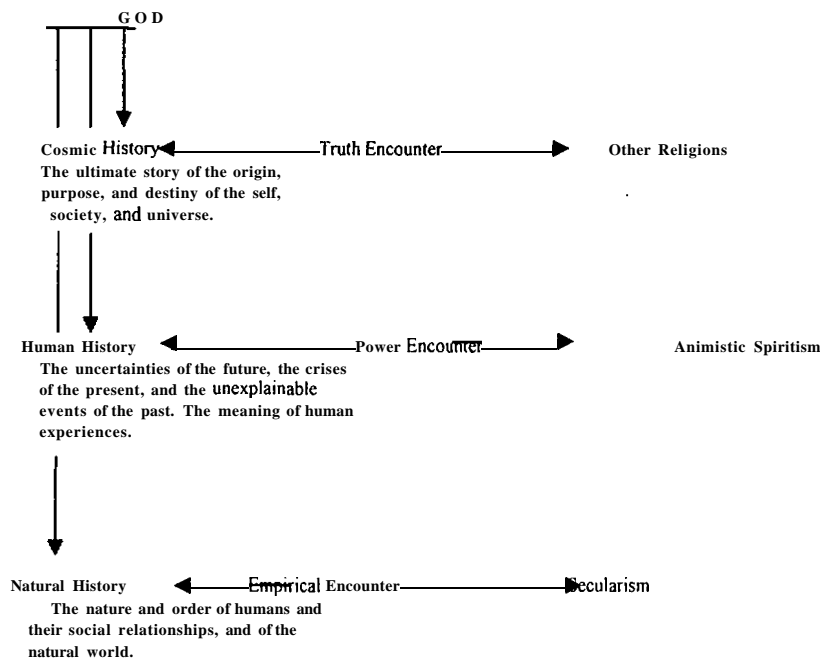

Source: (Hiebert [1994] 2002:199).

Instead of accepting a two layer world-view in which God is confined to the supernatural world while on the other hand the natural world operates automatically by scientific laws, the missionary needs to accept God who is working on the middle level also. At the same time they must avoid the dangers of secularism which denies the reality of the spiritual area and may engender a Christianized form of Animism (Hiebert [1994] 2002:199-200).

Thai people are engaging the spiritual realm in their daily lives from birth to death. Their world-view is **supernaturalistic**. They see all phenomena as an integrated whole and believe that the world or cosmos is controlled not only by human powers but by supernatural powers also (Davis 1993:35). Indeed, the unseen world is very real to the Thai people. John R Davis (:36) claimed both the Buddhist and Animistic character of the Thai world-view in this way:

Although others maintain that these are two opposing religious systems, the Thai people see no inconsistency between an organic Animistic world-view with its multitudinous gods and spirits, and a mechanistic Buddhist world-view; they marry conveniently and live harmoniously together.

The task of evangelizing the Thai is not easy. They have strong social solidarity through Thai folk Buddhism which includes the elements of Animism, Brahmanism and Theravada Buddhism. They constantly reinforce and maintain fundamental beliefs and assumptions derived from their

history. They also teach their world-view to their descendants without ceasing. Any change of their world-view is often resisted and ostracized because the whole society is unified in its beliefs. Nevertheless if we do not avoid the excluded middle level in the Thai situation, it may be possible to transmit Christian witness to them. The Christian message must be able to satisfy the spiritual desire of the Thai in these difficult circumstances.

3.5 Some factors which influenced the Thai church before, during and after John Sung's campaigns

In Chapter 3.3.2 we studied the Thai's understanding of European powers and Christianity during the first and second periods. This part is related to the third period of the Thai resistance to European influences and Christianity, from about 1938 to the present. It is generally accepted that during this period the missionaries made use of Thai Christians who had been compelled to follow the example of Western Christians. Although this period is connected with both Roman Catholic and Protestant mission, we shall concentrate on the Thai Protestant church only, and will restrict the period of this thesis to the events that occurred between 1938 and 1941.

John Sung visited Thailand for the first time in September 1938 and set off on a tour of about one and a half months. He visited again at the end of May 1939 when he toured for slightly over two months. The lives of the people who attended John Sung's campaigns in Thailand in 1938-1939 were affected by Phibun Songkhram's³¹ nationalism. We will, therefore, survey specifically the nationalism which impinged upon the lives of the hearers of John Sung's preaching at that time. Phibun Songkhram's nationalism programme exercised a direct influence on the lives of the Thai Christians during John Sung's campaigns. Therefore it is worth investigating the social situation of that time.

Phibun Songkhram received advanced military training in France and became a leader of the young military group responsible for the overthrow of the absolute monarchy in 1932 (Wyatt 1984:252). He became Minister of Defence in 1934 and Prime Minister in December 1938 (:253), and stepped down from the position in July 1944 (:260). He used King Rama VI's ideas as a nationalist model (Vella & Vella 1978:269). When we compare the two nationalisms, the king by and large relied on voluntarism, exhortation, and propaganda while Phibun Songkhram applied

³¹ The English spelling of his name differs such as, Phibul Songkhram, Phibun Songkhram, and Phibul Songgram etc. We will render his name as Phibun Songkhram.

compulsory measures. His nationalist programme can be summarized the three tendencies, to wit, militarism, economic nationalism, and cultural nationalism (:270).

His programme was militaristic and his power base was the army (Vella & Vella 1978:269). He followed not only King Rama VI's example but also the ultra-nationalism of the rising dictatorial regimes in Italy, Germany, and Japan (:270). Fifteen out of twenty-five of his cabinet members were military men (Wyatt 1984:253). The militarism partly derived from his military background and he borrowed heavily from Japanese warrior codes. He started the militaristic youth movement, *the yuwachon*, in 1935 (Vella & Vella 1978:270).

Phibunsongkhram's cultural nationalism was more resolute than that of King Rama VI. The name Siam was replaced by Thailand, or 'the land of the free' in 1939 to encourage the building up of a new nation (Kennedy 1968:58). He also stressed the linguistic kinship with Thai speaking peoples outside the borders of the country (Wyatt 1984:253). A series of twelve Cultural Mandates were issued by the Thai government between 1939 and 1942 to uplift the national spirit. The government required the people to salute the national flag and know the national anthem and use the national language. The cult of the leader was built up by slogans, newspapers, and radio (:255).

The cultural nationalism included the patriotic interpretation of Buddhism (Kennedy 1968:57). King Rama VI led a movement for the revival of Buddhism before Phibunsongkhram. Under his patronage an attempt was made to educate and strengthen the Buddhist clergy. He was the defender of the Buddhist faith in imitation of the British king's title (Panikkar 1970:272). Historically the Theravada Buddhism of the Thai showed remarkable strength in its social organisation, and was the great binding force which enabled their society to maintain their internal strength with outstanding success, from the disruptive forces of missionary activities and of Western ideas alike (:273). Phibunsongkhram's government emphasized Buddhism as a power for building the spirit of nationalism. *The International Review of Mission* (South-East Asia 1941:24) reported that the rise of a spirit of nationalism allied with the national faith which was Buddhism presented great difficulties to Christian evangelism. It had no small effect on Christian people because people were incited to use religion to persuade Christians strongly to apostatise their faith and accept Buddhism. It turned out that quite a number of Christians could not stand up to these constraints and to their exclusion from society resulting in the fact that they declared they were abandoning their faith. Most of the persecution took

place in the north, especially in the countryside where people did not know the law. When there were threats and persuasion they easily abandoned their faith (Pongudom 1984:89). On 8 February 1941 the head of Phrae Province, Paa Bpromkarn, sent an official letter to coerce the Christians to abandon their faith and accept Buddhism as follows:

On the 11th February 2484³² at 5 P.M. corresponding to the Third Month (Fifth Month in North), the 15th day of waxing of the moon, the authorized Changvat Committee, consisting of the Commissioner as chairman, will perform the ceremony for receiving Government officials and other citizens who held the Christian religion and voluntarily have changed and want to become Buddhists. Therefore it is hereby announced to all Thai people who hold to the Christian faith that they should voluntarily return to Buddhism, which is the indigenous religion of the Thai race, and when any one has such a desire to make the cha[n]ge of heart, let him give notice to me before the 10th of February of this year, I will then be glad to take such a person for the ceremony of conversion to Buddhism at the Bote at Wat Prabaht on the 11th of February 2484.

When we read that letter, it might appear that the head of the Phrae Province had given Christians the freedom to decide voluntarily whether to follow the guideline or not. Prasit Pongudom (1984:89) asserts that for the most part people feared the power of government officials, so when there were threats and persuasion they easily abandoned their faith. He continually gave evidence that the moderator of the CCT abandoned his faith and accepted Buddhism in 1941 because of severe pressure from the government (Pongudom 1984:90). *The International Review of Mission* (South-East Asia 1942) reports on the serious situation at that time:

The growth of a nationalist spirit has manifested itself in recent months in the pressure, sometimes amounting to social ostracism, applied to Christians to return to Buddhism... The majority of those renouncing their faith are reported to have been senior government officials (:20).

The reports also said that the nationalism which had exploited Buddhism was evidently inspired to some extent by outside totalitarian influences (South-East Asia 1942: 20)

On 8 December 1941 the Japanese invaded Thailand and on 12 December 1941 the Thai government agreed to a military alliance with Japan. In January 1942, the Thai government declared war against the United States and England (Wyatt 1984:256-257). The missionaries in the north fled to Burma while those in the south were confined in the prisoner of war camp

³² 2484 is the name of a Buddhist Era which is the same as 1941.

(Pongudom 1984:91-92). All the missionaries were repatriated and the Thai churches were left in the hands of Thai leaders only. The Rev **Boonmark Gitisarn** (1979), one of the representatives of the protagonists of John Sung's campaigns, testified that he had encouraged Christians to be steadfast in their faith during the war. Some other Thai Christian leaders who were strengthened by John Sung's campaigns, who also, were the Rev Sook **Pongsanoi** and the Rev **Tongkham Panthupong**, who also continued with their pastoral activities for the scattered Christians during the hard war years (Kim 1980:63). We shall look into this matter in Chapter 6.2.5.

The economic nationalism programme was closely related to the Chinese in Thailand at that time. Phibunsongkhram government's economic nationalism was "Thailand for the Thai" (Wyatt 1984:254) and "economic **Thai-ification**" (Skinner 1957:261-262). The programme was a fatal blow to the Chinese. It is generally accepted that the Chinese are experts in economics and control the economy of the East Asia. Today Thailand's population is 10.5% Chinese who control 85% of the Thai economy (Johnstone, Mandryk & Johnstone 2001:619). "The Thai turned against the Chinese as the major cause of their economic ills" (Buss 1958:57). Two elements fuelled anti-Chinese sentiment. The first was that the Chinese in Thailand remitted large amounts of money to their relatives in China which contributed to a drain on the Thai economy. The other element related to the political situation in China. Chinese nationalism flared up when the **Sino-Japanese War** began in 1937 and the Thai Chinese organised anti-Japanese movements although Japan was the major trading partner of the Thai at that time. When Luang Wichit gave a public lecture he compared the Chinese in Thailand to the Jews in Germany and implied that Hitler's policies toward them were worth considering (Wyatt 1984:254). "The government's program of economic Thai-ification, so intensively pursued during the twelve months beginning December 1938, completely stunned the Chinese community." The government helped the Thai rice company to buy several Chinese mills in Bangkok in December 1938. The government also took over the salt, tobacco, petroleum, and pork business of the Chinese in order to give the Thai control over their own economy (Skinner 1957:264). Chinese schools and newspaper companies were closed (:266) and several hundred Chinese arrested (:267). "[S]ome of its acts of economic nationalization affected Western multinational corporations as much as they affected Chinese enterprise" (Wyatt 1984:254). Certainly, restrictions applied to every nationality except the Thai. However the Phibunsongkhram government's economic nationalism in 1938-1939 primarily affected the Chinese (Skinner 1957:264). For them, Thailand was not a happy place in 1938 and 1939. It is

certain that they were pressured by nationalism in all areas of their lives. The persecution possibly contributed towards their accepting Christ more easily than Thai people. At the same time we can concur with the well-founded conjecture that the political and economic disorder of **Phibunsongkhrām's** government plus the war contributed to Thai people to provide more amenable circumstances for accepting the gospel more easily than before.

Thailand secured her independence from Japan in return for alliance with Japan (Wyatt 1984:257). After Japan's surrender on 15 August 1945, Thailand recovered the relationships with the Allies. They were fast to promote their own best interests thus evading possible danger. They settled their disputes diplomatically. After the war **Seni Pramoj**, Thai minister in Washington who was the leader of the Free Thai movement during the Second World War, apologised to the Americans that the Thai government had allied with Japan because of Japanese military pressure. They continually gave the poor excuse that Thai troops had not engaged in warfare against the Allies. In the end they persuaded successfully not only the United States but also England through the help of the United States (Wyatt 1984:261).

From these incidents we realise that the Thai are smart in retaining their liberty. They utilised the Western powers to the fullest for their interests and independence. They played off one Western power against another in order to benefit themselves. They are excellent at equidistance in diplomacy in times of crisis. The strangeness of Christianity still remains in Thailand. The foreignness of Christianity is one of the biggest obstacles in the propagation of Christianity in Thailand. **Nantachai Mejudon (1997:229)** concluded from his research that "the idea that Christianity is the religion of the whites made them hesitant to come to Christ." Let us take heed to the meaningful comment of **Supanni Kanjancatthiti (1964:iv)** as conclusion:

Thailand is the only country in Southeast Asia which has made full use of the benefits of Western civilisation and knowledge which missionaries gave, and which is the pathway to knowledge and thought that is up-to-date until we are able to adapt ourselves in time to events and continue to keep our independence in a way that ensures equal standing with Western countries in every way.

The country retained its independence by means of strong nationalism, playing one foreign power against another, together with the use of both the monarchy and Theravada Buddhism.

3.6 Summary and conclusion

Thailand has been known one of the least fruitful countries in mission work. Alex G Smith represented this in the metaphor "slicing a sword through a lake's water" (2001:21). Historical, **socio-cultural**, and religious circumstances played an important role in moulding the Thai. Those elements are crucial if we are to understand the reason why the Thai do not respond positively to the gospel. It seems safe to conclude that many factors influenced the results of John Sung's ministry.

William C Dodd referred to the original Thai race of the present time as being the Tai who are the elder brother of the Chinese. He claimed that the Tai race has more than 4,100 years of recorded history (Dodd [1923] 1996:19). Nevertheless, historians still do not know the place of origin of the Thais. It seems most likely, according to historians, that the ancestors of the Thai came from southern China. Thai history can be divided into four periods, the Sukhothai period (AD 1238-1438), the Ayutthaya period (AD 1350-1767), the Thonburi period (AD 1767-1782), and the **Ratanakosin** period (AD 1782-until the present). Certain legendary rulers are important in each era. King **Ramkhamhaeng** who invented the Thai alphabet in 1283 is the most prominent king in the Sukhothai period. The Ayutthaya period denotes the most flourishing period of Thai history. Thirty-three kings reigned during this time. The Thonburi period was very short-lived and in 1782 the Ratanakosin period was started by King Rama I. The present dynasty is the **Chakri** Dynasty which has reigned from that time until now. The present king Bhumibol Adulyadej, King Rama IX, has reigned since 1946. In 1932, Thailand changed from an absolute monarchy to a constitutional one.

Generally speaking, the Thai lacked interest in compiling historical accounts (Vella & Vella 1978:204). Thai historical records were sketchy and the people had only the most meagre knowledge of their history (:203), but Thai kings have put their heart into the production of historical accounts and preserving of old sites and ancient objects. King Rama IV (1851-1868), while he was still a Buddhist monk, was responsible for collecting a number of important stone inscriptions. King Rama V (1868-1910) collected many stone steles into the royal museum. King Rama VI (1910-1925) accumulated rubbings of inscriptions. The members of the royal family and high nobilities took the lead in visiting the ruins of old sites and encouraging the production of historical materials (:205). They persuaded the people to believe that the Thai had a proud past (:204). They also encouraged the people to erect monuments to commemorate the victories

recorded in old historical accounts and to erect statues of old heroes (:207-213). In summary, the Thai history played an important role for the people. The Thai kings and high nobles made use of Thai history to reawaken the Thai people's loyalty to their king, their devotion to Buddhism, and to promote national identity and their sense of unity.

Characteristics of Thai personality are a most important aspect of the socio-cultural factors. **Suntaree Komin's** analyses of value clusters of the Thai character have proved useful: ego orientation, grateful relationship orientation, smooth interpersonal relationship orientation, flexibility and adjustment orientation, religio-psychical orientation, form over content orientation, interdependence orientation, and fun-pleasure orientation. These characteristics govern their behaviours. Paul G Hiebert (1988:49) postulated that "the more integrated cultures are, the more stable they are—but also the more they resist change." Thai culture is basically eclectic in nature in that it has shown a strong power of absorption and has the capacity to melt together the cultures and belief systems of many racial groups including Chinese culture. Certain characteristics interact to protect and keep the identity of the Thai while on the other hand some elements contribute to the rejection of Christian witness.

It is not too much to claim that the unique Thai character was one of the reasons for the meagre fruit of the Thai revival of 1938-1939 through John Sung's ministry in comparison with the results of his work in other countries. Out of about one year and seven months of campaigning in the nine countries in Southeast Asia, he spent most of his time in Indonesia (five months), Malaysia (four months and two weeks), Thailand (three months and three weeks), and Singapore (two months and three weeks) (Sung 1995a:57-171). The percentage of contemporary Christians is the lowest in Thailand. Christians in Indonesia form 16 % of the population (Johnstone, Mandryk & Johnstone 2001:339); in Malaysia they form 9.21 % (:422); in Singapore, 14.6 % (:566); and in Thailand, 1.62 % (:619). These are the **relavant** facts of John Sung's success or lack of success in Southeast Asia. For Thailand the revival of 1938-1939 was the biggest that the country has experienced. However in comparison with results in other countries it was not as **big—this** can most probably be attributed to the Thai character. The self-sufficiency of the Thai character is discussed in subsection 3.3.1 of this thesis.

The Thai identify Christianity with the white people. They call Christianity *satsana farang* which means foreigner's religion. There is dualism in the Thai's attitude towards Christianity and European influences. On the one hand, there is resistance to Christianity and European

powers at the political level but on the other, acceptance of the technical power of the West to protect the independence of their country. They have a genius for keeping their independence and using equidistant diplomacy when engaging European powers to benefit themselves. During the first period from 1511 to 1828 the missionaries depended upon the power of the West. This tendency caused the Thai to misunderstand Christianity as a **foreigner's** religion. During the second period the missionaries still relied on Western civilisation in their mission work. J Verkuyl (1978:170) testified that "[t]he coryphées of cultural Protestantism in the nineteenth and twentieth centuries viewed missionary work as primarily a means of transmitting the values of Western culture." The American Presbyterian missionaries mainly used educational and medical avenues in the propagation of the gospel. Thai leaders made use of Western science in developing nationalism and Buddhism. Thus even though the missionaries worked hard their efforts bore little fruit in terms of gaining converts.

The Thai accepted Mahayana Buddhism first and then changed Theravada Buddhism into a state religion when King Ramkamhaeng ruled the Kingdom of **Sukhothai**. From that time Theravada Buddhism developed without hindrance until the present. It would be more accurate to say that Animistic practices existed long before Buddhism. During the Ayutthaya period the Thai adopted the Brahmanism of the **Khmers** including the court Brahmanism which was associated with the royal court and the folk Brahmanism which was found among the whole population. Thai Theravada Buddhism is not pure and orthodox Buddhism but folk Buddhism which accommodates Animism and Brahmanism without any sense of conflict. "The amalgamation of many religious elements under Buddhism produced a strong national, racial, and religious identity with Buddhism. This has become the strongest barrier to conversion and an obstinate obstacle to evangelization" (Smith 2001:21-22). Theravada Buddhism, Brahmanism and Animism are harmoniously combined with each other without conflict.

Generalization is often dangerous but it will not be far from the truth to say that Western theologies are not able to understand the necessity of the Two-Thirds World because they are heavily influenced by the Enlightenment. Paul G Hiebert argued that Western missionaries ignored the middle level of supernatural beings. He delineated the phenomena as "the flaw of the excluded middle." He suggested a holistic theology which could embrace a super naturalistic world-view. While Buddhism is a philosophy with no God, yet they do not hold a naturalistic world-view but a super naturalistic world-view. And they accept the whole idea of sacred things in the world. The whole area of the universe being pervaded with spiritual being is an important

part of their psyche. They learn more about demons in their childhood than about Buddhism. As John R Davis (1993:36) claimed, the organic Animistic world-view with numerous gods and spirits, and a mechanistic Buddhism can be dealt within a holistic theology.

The social climate before, during and after John Sung's campaigns, from 1938 to 1941, is permeated by Prime Minister Phibun Songkram's nationalism. His nationalism programme consisted of a militaristic, economic and cultural type of nationalism (Vella & Vella 1978:270). In particular, his economic nationalism which focused on economic Thai-ification in 1938-1939 primarily affected the Chinese. It would not be a mistake to suppose that the hardships enabled the Chinese to accept the gospel more easily than the Thai people. Concurrently the turbulence of nationalism and the Second World War helped Thai people to respond to the gospel more easily than the normal situation. As Supanni Kanjacnathiti (1964:iv) claimed, Thailand is the only country in Southeast Asia which made full use of the benefits of Western civilisation and knowledge and yet was able to continue to keep their independence and to have equal standing with Western countries.

In his book, *Waterbuffaloheology*, Kosuke Koyama (1974:129) says that as a missionary in Thailand what really matters is not the doctrines of Buddhism but *people* who are trying to live according to the doctrine of the Buddha. The writer remembers a Thai man once saying to him, "I have never sinned." It is difficult to help one who does not sense a need. Thai people generally insist that all religions are equally good and have the same goals which help make people good. More than that "all kinds of religious and superstitious elements can be harmoniously integrated in the syncretistic nature of the Thai society" (Kim 1980:16). Certainly their religions have an inclusive and relativistic character but they are unbelievably slow to accept the faith in one God. The more we understand the three factors, that is, historical and socio-cultural and religious elements which affected the result of Christian witness, the more we feel that sharing the gospel is tough work. The social solidarity among Thai Buddhists is extremely strong. Nonetheless, the writer prays that the merciful God can help the Thai Buddhists by his power. He completely agrees with Alex G Smith (2001:32) that only the Holy Spirit can open blind eyes to see the truth of Jesus Christ.

Chapter 4. John Sung

4.1 Introduction

John Sung made the greatest contribution towards revival in the history of the Chinese church. He is one of the big giants in the history of the Chinese church (Liu 1982:141). Leslie T Lyall ([1954] 1965:vii) designated him as "the greatest evangelist China has ever known." Out of a total of one million Protestants in China before the Communists took control in 1949, several hundred thousands of people were born again and filled with the Spirit under John Sung's ministry (Tow 1988:49). His life story is dramatic and unusual. He had unique characteristics that influenced his ministry. God used him as a powerful instrument for his glory both in China and in Southeast Asia. This chapter does not focus on John Sung's impact in China but considers his ministry in Southeast Asia.

4.2 A brief history of John Sung's life and his ministry

It would be valuable to divide John Sung's life into three periods. These are the periods of his childhood and boyhood in China, studying in America and five three-year periods.

4.2.1 Childhood and boyhood in China (from 27 September 1901 to February 1920)

John Sung was born on 27 September 1901 in Hinghwa in the Fukien Province. He was the sixth of ten children of a Methodist pastor. John Sung was the first child born after his mother was converted, so he was given the name **Ju-un** meaning "God's grace" (Lyall [1954] 1965:3). His father, pastor Sung, worked with the American Methodist Episcopal Mission all his life (:4). Pastor Sung served in the ministry for forty-four years. He was a good writer and speaker (Sung [s a], 4:1). Pastor Sung was appointed assistant principal of the Methodist Bible School in Hinghwa about 1907. At the church day school John Sung showed signs of exceptional ability. He experienced his younger sister's death so he faced the mystery of death at a young age (Lyall [1954] 1965:6-7). The Hinghwa revival broke out at John Sung's father's church in 1909 and there were about three thousand conversions when he was nine years old (:8-9).

John Sung's family was poor but the home had a warm spiritual atmosphere. They usually had family worship together. During the worship each family member played a musical instrument. In this way John Sung was able to develop musical capability from childhood (Sung [s a], 2:17). He helped with his father's work when he became a high school student. When his father could

not fill his position, John substituted for him. He had a good memory, so he could compose good Scriptural sermons as the "little pastor." He accompanied his father on preaching trips in the villages, through open-air preaching, giving out tracts, selling Bibles and conducting the singing (Sung [s a], 2:12-13). John Sung's father edited a magazine, *Revival*, and he became the assistant editor of the magazine. His father had many books and he enjoyed reading books from his father's library. From about 1917, he began to write a diary and kept up that habit for the rest of his life. When he finished high school, his eldest sister died suddenly so that he was once again reminded of the uncertainty of life (Sung [s a], 2:14-15).

John Sung once said "[w]hat I am today is all from my father" (Sung [s a], 4:1). It seemed that he inherited his father's hot temper (Lyall [1954] 1965:5). He also acquired many good things through his father, especially spiritual assets. He learned the habit of keeping a diary from his father and his father taught him how to preach from the time he was nine years of age. He thanked God for all the good seed sown in his heart while he was young (Sung [s a], 4:2). It is no exaggeration to say that God used his father for moulding him in many ways. During the formative period of his faith, his father's character was a great influence on John Sung.

4.2.2 Studying in America (from March 1920 to November 1927)

God heard John Sung's prayer about his need for money for travel expenses and a scholarship from Ohio Wesleyan University. He arrived in America in April 1920. He was supposed to study Theology but he changed his major to Chemistry. Even though he supported himself during his studying by getting many kinds of jobs, he received three academic degrees in five years and two months, these being B.Sc, M.Sc. and Ph.D. in Chemistry (Sung 1995a:6-13). He displayed such great ability in his studying that he was among the top four students in physics and chemistry to win prize money and a medal for his B.Sc. degree work (Sung 1977:58). He also demonstrated natural leadership and charisma when he led the International Students' Association (Lyall [1954] 1965:25). He was diverted from his faith by accepting a Social Gospel. At one time he "referred to the manhood of Jesus" (Sung 1977:67).

Having been reminded of God's call for him to return to China for full-time ministry, Sung enrolled at Union Theological Seminary in New York in September 1926, where he was deeply influenced by liberal theology. He lost his faith and joy in Jesus Christ. When he struggled to recover his first love for Jesus Christ, the preaching of a young girl impressed him (Sung

1995a:13-15). Following this, on 10 February 1927 he deeply repented and had a vision of the Lord standing before him. He felt intense release from his sins after hearing a voice saying to him, “[y]our sins are forgiven! Your name is changed to John” (Sung [s a], 4:6). He had a meaningful dream a few days after his conversion on 10 February 1927, which decided the direction of his remaining life. He had seen himself as a dead corpse dressed in academic cap and gown, and clasping a diploma in his hand in an open coffin. When a voice said, “John Sung is dead,” the angels began to weep. And a voice said, “[w]eep not, ye angels, I will remain dead here—dead to the world and dead to my selfish ambitions” (Tow 1985:85). He received the Lord's message that he was to witness to all nations. After he had experienced new birth, he began to praise God loudly and shared the gospel with people with eagerness. His unusual change of character caused the Seminary authorities to misunderstand him, and to think he had become a mentally unbalanced person (Sung 1977:77-81).

He was sent to Bloomingdale Mental Hospital where he was for one hundred and ninety-three days from 17 February to 30 August 1927. He read the Bible through forty times, following different key thoughts. He called the mental hospital his personal “Bible School” (Sung 1995a:17-19; Sung 1977:82-86). He said that his one hundred and ninety-three days in the hospital “comprised the most significant page of my life” (Sung 1995a:19). In the hospital, God trained him as a man of only one book, the Bible. He always looked back upon his days in the hospital as a significant time in his life. Through his conversion experience on 10 February 1927 and his one hundred and ninety-three days of retention in the mental hospital, God enabled him to turn away totally from liberal theology and Social Gospel.

Leslie T Lyall ([1954] 1965:40) delineated his decisive brave conduct most impressively:

Like Paul, he would renounce the world and its fame once for all: he would burn his bridges behind him. One day, as the vessel neared the end of its voyage, John Sung went down to his cabin, took out of his cabin trunk his diplomas, his medals and his fraternity keys and threw them overboard. All except his doctor's diploma, which he retained to satisfy his father...“There must be great renunciations...if there are to be great Christian careers.”

When John Sung recalled the dream of “an open coffin” after his conversion experience of 10 February 1927 on deck, he made a resolute decision to throw away all medals, gold

keys and diplomas except the Ph.D. diploma, which was saved out of filial piety for his parents, for the sake of Christ in **Phlp** 3:7-8 (Tow 1985:86).

4.2.3 Five three-year periods (from November 1927 to 18 August 1944)

John Sung came back to China in November 1927. When he refused to become a professor in a National University, his father was disappointed and suspected that he was deranged, observing him for a month (Sung [s a], 4:8).

John Sung told the Rev William E Schubert, John Sung's "closest and most esteemed missionary friend" (Sung 1995a:20), about the **five** periods of three years each of his life that Christ revealed to him in 1931. The five three-year periods (Lyll [1954] 1965:56; Tow 1988:46) are the water; the door; the dove; the blood and the tomb periods (Schubert 1976:23). The last period, the tomb, does not fit into three years exactly, but lasted for almost four and a half years.

The "Water period" covered the time from November 1927 to November 1930.

John Sung was employed part-time as a Chemistry and Science teacher at the Methodist Christian High School of his old school (Lyll [1954] 1965:46). He was against the nationalism of the nationwide practice of bowing to the portrait of Sun Yat Sen, Father of the Chinese Republic (1867-1925). The **Kuomintang**, the Nationalist party, pressured the School Board which made John Sung resign from the School. He was married to Jean Hsu on 18 December 1927 (Sung 1995a:20). He began itinerant preaching ministry and trained young people in groups as lay preachers (Tow 1985:91-92). He attended a Christian summer conference to listen and asked permission to give a testimony. The testimony was his introduction to the Chinese church on the whole. In the autumn of 1928 he formed an itinerant preaching band (Tow 1985:93). He visited many places in 1929 (Lyll [1954] 1965:51). He "formed an itinerant Theological School" and spent one whole year on the training of Christian workers in 1930 (Tow 1985:95-97). During the water period alongside a preaching ministry he was involved in many other works such as "religious education, family worship, youth work, literacy, social work, etc" (Tow 1985:108). These first three years comprised his solo ministry.

The "Door period" lasted from November 1930 to November 1933.

John Sung's wider ministry in China began in November 1930 through a special opportunity. "[T]here was a big Religious Education conference near Shanghai, and John Sung was sent as a delegate, not as a speaker, but to learn from others." When a noted lady missionary saw the materials which John Sung had prepared, she asked him to take her place as a speaker. After that meeting, John Sung was invited to preach in **Nanchang** by pastor Hsu who had heard his preaching at the Religious Education conference and shared thoughts about John Sung with Rev William E Schubert who also heard him there (Schubert 1976:25-26; Lyall [1954] 1965:60). Both of them had been praying for revival since 1 January 1931 for fifty days, and John Sung came to Nanchang in the middle of February 1931. On the night of 5 March 1931, he realised God's guidance and that he had to "attack the stronghold of sin in the human heart" and "deal with sin's power over men's lives" more than anything else. That kind of message was effective to bring people to repentance (Lyall [1954] 1965:61). The occasion of Nanchang "became the turning point in his whole ministry" (Tow 1985:108). The Holy Spirit fell in a new way on John Sung (Schubert 1976:38). He believed firmly that what the Chinese needed was Jesus Christ and his cross (Tow 1985:69). Five men including John Sung started the Bethel Gospel Band on 9 May 1931. "They travelled to many provinces to conduct evangelistic meetings" (Sung 1995a:20). John Sung preached with the Bethel Gospel Band in many places in Manchuria in 1931 (Lyall [1954] 1965:73-89), in south China in 1932 (:90-98) and in north China in 1933 (:99-111). In November 1933 an untrue rumor that John Sung intended to become a pastor in **Beijing** caused Miss Jenni Hughes, the Treasurer of the Bethel Gospel Band, to dissolve the band and form a new World Gospel Band. Miss Jenni Hughes dismissed John Sung from the band (Sung 1995a:21). Miss Betty Hu testified that John Sung "did the work of hundreds of preachers in those few short years" (Lyall [1954] 1965:120). Tens of thousands of people were converted through his ministry.

The "Dove period" continued from November 1933 to November 1936.

From 1934 until his death in 1944, John Sung ministered alone. "During this time the Holy Spirit was poured out on the church in China, and Dr Sung himself had some 100,000 converts" (Schubert 1976:23). On 1 January 1934 he prayed for one hundred thousand souls to be brought God. He "pleaded for a double portion of the Spirit that God gave to Finney, Moody, and John Wesley, that the fires of revival would be lit wherever I went and would never be extinguished"

(Sung 1995a:23). The fires of revival reached south China in 1934 (:36-46) up to the north and outside of China in 1935 (Sung 1995a:46-74). His preaching tours brought him to various countries in Southeast Asia such as the Philippines, Singapore, Malaysia and Hong Kong in 1935 and Taiwan, Hong Kong, Singapore, Malaysia in 1936 (Sung 1995a:57-95). His ministries changed the course of the gospel history in those countries. God opened a worldwide personal ministry for him during the Dove period.

The "Blood period" continued from November 1936 to December 1939.

During that time Japan attacked China and China bled. John Sung himself also bled on account of a fistula and bleeding bowels (Schubert 1976:23-24), but he continued his ministry within China and overseas that is, in Burma, Malaysia, Hong Kong, Vietnam, Thailand, Singapore and Indonesia. He left indelible traces of the gospel in these countries (Sung 1995a:96-171). His ministry in Southeast Asian countries will be discussed in detail in Chapter 4.5.

The "Tomb period" can be dated January 1940 to 18 August 1944.

Dr Huang diagnosed five anal fistulae in John Sung in Penang in December 1939 (Sung 1995a: 166). John Sung came back to his home in Shanghai on 18 January 1940 via Singapore (Sung 1995a:168) and Hong Kong (Sung 1995a:172). He underwent many operations but he never spared himself in his ministry. The Grace Church in Shanghai invited him to conduct meetings from 10 to 16 November 1940. During those meetings his old disease worsened (Sung 1995a:183). He got visas to visit Southeast Asia to finish his work there, but it was not possible to work any more because of his illness (Sung 1995a:190). In December 1940 he was found to have cancer and tuberculosis as well (Lyall [1954] 1965:184). He continued to lead worship and Bible study groups with his family members, friends, Christian workers of the hospitals and visitors (:185-187) because he firmly believed that God wanted him to deny himself completely and magnify the Lord (Sung 1995a:181). He admonished others that "to please God is more important than to do great ministry" (:180). He admitted that "intimate communion with God is of paramount importance" (:204) and prophesied "one day all the Western missionaries will leave China" (:183) and the nation of Israel would be reestablished (:185). He was a man of prayer till the end. Like John the Baptist, John Sung died in his prime on 18 August 1944 at the age of forty three. Wang Ming-tao preached at his funeral service and said "John Sung had been

called, like Jeremiah, to rebuke the sins of the Church and of society, to be as an iron pillar, fearing no man and faithful unto death" (Lyll [1954] 1965:189).

4.3 Four unique features of John Sung's character.

John Sung was unusual in many ways. God used him exceptionally in his ministry. He was "[a] man greatly beloved, yet greatly hated; bitterly criticised, yet utterly careless of criticism" (Lyll [1954] 1965:xxii). There were several unique characteristics concerning his personality but we choose four points, both strong and weak.

4.3.1 John Sung was a dedicated servant of God.

John Sung laboured for God "with all his might, like running a hundred-meter race" (Tow 1988:43). He was an extremely industrious man. He used every minute profitably (Lyll [1954] 1965:192). "Between the meetings he could never relax" (: 162). "He laboured as a man whose days were numbered" (: 192). At one time John Sung compared himself to his contemporary servants of God (: 164):

There are many people better than I! For exposition of the Scriptures, I am not equal to Watchman Nee! As a preacher, I am not up to Wang Ming-tao! As a writer, I cannot compare with Marcus Cheng! As a musician, I am far short of Timothy Dzaio! I have not the patience of Alfred Chow! As a public figure, I do not have the social graces of Andrew Gih! There is only one thing in which I excel them all: that is in serving God with every ounce of my strength!

John Sung himself acknowledged that he stood high above the others in his devotion to the Lord. "He was wedded to the Cross. He glorified in the **Cross**...He recklessly forsook all to follow his Lord. With all his superficial faults and idiosyncrasies, he was a man after God's own heart" (Lyll [1954] 1965:193). He asked himself what life was for and answered himself: "Life is to be God's instrument. Eloquence and wealth are nothing. We should give over [all of] these for the Lord's use, for we need God" (Sung [s a], 5:25). He preached that "The more we fear, the more we die! The more we dare to die, the more we live!" (Sung [s a], 3:14).

In the foreword of *John Sung* by Leslie T Lyll, John Stott gives a unique evaluation of John Sung ([1954] 1965:viii-ix):

He knew what it was to deny himself and follow Christ... He was no seeker of fame and no lover of money. He had no hunger for popularity. He hated flattery... never to advertise himself. Like his Master before him, he sought not his own glory. He was willing to be a fool for Christ's sake... He desired to live unto God only... He was on fire for God, "a living flame of gospel zeal." He never spared himself... He would go on preaching until his clothes were wet with perspiration, and would ignore the pain of his illness, resolved if possible to die on the platform... John Sung loved God and souls. That was all.

He never spared himself but denied himself entirely. He lived his day by day life just as if it would be the last day for God's glory.

4.3.2 John Sung was a fearless man.

John Sung "played the part of John the Baptist in his fierce rebukes, and was particularly outspoken in his condemnation of ministers who were preaching another gospel or contradicting the truth by their lives" (Lyll [1954] 1965:x). John Sung's denunciations of sin were fearless. Sometimes he would call a pastor or office bearer in the church and say, "There is sin in your heart!" (Lyll [1954] 1965:142). He was not afraid of anybody including missionaries. "[H]e preached one day on the revival in Samaria" and compared "the failure of Philip's ministry to the failure of the work of the missionaries" (Lyll [1954] 1965:xx). He preached with certainty as follows:

Trusting God, you need fear nothing (Sung [s a], 2:14). Trusting Jesus you can triumph over all... Trusting Jesus, trusting God, we are more than conquerors in everything (:15). The disciples were killed for Christ. Brothers and sisters, there's a crown of glory awaiting martyrs and we should die for Christ (Sung [s a], 6:15).

He did not fear anything but sin. He gave equitable treatment to all levels of people.

4.3.3 John Sung was a candid and simple man.

"Like Jesus he loathed hypocrisy. He never hesitated to denounce with scathing candour the hollow mockery of nominal Christianity in people and pastor alike" (Lyll [1954] 1965:x). When somebody indicated his errors, he was willing to apologise (Lyll [1954] 1965:158). While John Sung toured north China in 1937, he met some Christians who remembered his brusque manners in the meeting at Pingyao in May 1933. John Sung offered his sincere apology for his haughty

attitude toward the Christians there like this. "When I was with you in 1933, I was very **carnal!** But I hope you will see a change for the better in me now and **find** me rather more **spiritual!**"

Even though he was a scholar and a scientist he was never pedantic in his sermons (Lyall [1954] 1965:xxii). His dress was simple and his appearance was normal all the time (Lyall [1954] 1965:162).

4.3.4 John Sung was a person of an impetuous disposition.

John Sung had a quick temper from an early age (Lyall [1954] 1965:5). On occasion, he and his brother "were sitting in the courtyard eating their breakfast rice when a quarrel started and he threw his hot rice into his brother's face in anger, scalding him and breaking the bowl!" (Lyall [1954] 1965:6). When he preached, many people were involved in interpretation from his dialect into the local dialect. If the interpreters were slow or made a mistake he would abruptly order that the interpreter be replaced (Tow 1988:43; Lyall [1954] 1965:149-150).

Once bus traffic was halted because of heavy rain. So the departure of John Sung's team members delayed the campaigns in south **Shansi**. John Sung was impatient at the delay of the bus. He angrily berated the bus station manager for the non-arrival of the bus. This seems a strange reaction by a preacher who had just completed a week of the most powerful preaching! (Lyall [1954] 1965:xx).

But Mr G E Metcalf of the China Inland Mission testified to the change in John Sung during the summer of 1938. When John Sung saw Chinese Christians and missionaries who were labouring for God with great self-sacrifice, he seemed to become a more humble person than before (Lyall [1954] 1965:163-164).

4.4 An analysis of the distinctive features and emphases of John Sung's theology

There is no point in analysing all of John Sung's theology. It is necessary to examine the notable and important side of his theology. Although he studied theology at the Union Theological Seminary in New York for about six months, from September 1926 (Lyall [1954] 1965:29) to February 1927 (Sung 1977:82), he was not a theologian. Nevertheless he had a distinctive theological direction. Leslie T Lyall ([1954] 1965:146) states that, "though Dr Sung was no

theologian, he never hesitated to enter into controversy in defence of what he saw to be the right. He held his convictions with great tenacity." It is not too much to say that his real theology was formed at Bloomingdale Mental Hospital (Sung 1977:85). He was never bound by the theology of a denomination. Timothy Tow asserted that John Sung's doctrinal emphasis was above a denomination's (Tow 1988:46). His theology of revival will be discussed in Chapter 6.

4.4.1 Opposition to liberal theology or the Social Gospel

The Social Gospel is "[a] 19th- and early 20th- century American movement, primarily found in Protestantism. It applied the Christian faith to contemporary social conditions in an industrialized society and focused on impoverished urban workers. It stressed justice and the establishment of the kingdom (reign) of God" (McKim 1996:262-263). On three occasions John Sung repudiated liberal theology or the Social Gospel as he saw it.

The first occasion was related to his experience of being born again. When John Sung studied at Ohio State University, he was actively engaged as a leader of the International Student Association and the International League for Peace. He promoted goodwill to abolish racial discrimination and effected fund raising for needy students, which was in line with the Social Gospel and liberal theology (Tow 1985:65). When he studied at Union Theological Seminary he was influenced by liberal theologians like Dr Henry Sloane Coffin (1877-1954) (Weber 1990:295-296) and Dr Harry Emerson Fosdick (1878-1969) (Whiteman 1990a:446-447). He had been taught by them that the Bible is a partially inspired book (Tow 1985:69). Timothy Tow (1988:37-38) asserted, "[i]t is evident from a study of John Sung's life that God had sent him to Union Seminary, to taste the bitterness of liberal theology that he might find the grace and truth of the living Saviour the sweeter." When he experienced real new birth on 10 February 1927, he went to see Dr Fosdick and told him, "[y]ou are of the devil. You made me lose my faith, and you are causing other young men to lose their faith" (Tow 1988:73-74).

The second occasion was linked with his one hundred and ninety-three days of retention in the mental asylum. He devoted himself to study God's Word by the guidance of the Holy Spirit (Tow 1988:78). He stated, "[b]y the Lord's instruction I've derived 40 methods of study, reading the Bible 40 times" (:81). His confinement at the mental hospital made him grasp the Bible as the only truth and reject the Social Gospel and liberal theology for the rest of life.

The third occasion was connected with his experience of Nanchang on 5 March 1931. He made a decision to attack humanity's sin (Sung 1977:111). From November 1927 until he found the assurance of the real problem of humanity's sin on 5 March 1931, he was interested in all sorts of movements (Sung [s a], 4:14). When Dr Tojohito Kagawa gave a lecture on Social Gospel at Shanghai Christian University, John Sung communicated the efficacy of the cross instead of the Social Gospel (Lyall [1954] 1965:58). He strongly disagreed with Evangelism through social methods or liberalism. John Sung held firmly to one thing only, Jesus Christ and salvation from sin (Toktaeng 1984:110). After March 1931 he denounced liberal theology and the Social Gospel vigorously.

4.4.2 The **Word** of God

Timothy Tow affirmed John Sung's theology of the Bible thus: "More than ever a Fundamentalist after conversion, believing the Bible to be the infallible and inerrant Word of God, he took a strong stand against the Higher Critics." He solved all problems by referring to the Bible. Though he had visions and dreams during the days of spiritual conflict, he rarely mentioned these except in his conversion story. "His emphasis was on God's Word and the reading of the Bible" (Tow 1988:38). He soaked his heart and mind in God's Word (Lyall [1954] 1965:ix). He did not read any commentary on the Bible (Sung [s a], 4:27). "John Sung was a man of the Word. He loved it passionately. He knew the Bible as few know it" (Lyall [1954] 1965:192).

4.4.3 Christology

"John Sung was sound in Christology." The centre of his preaching was Christ who was crucified, had risen from the dead, ascended and is coming again. "[H]is sermons were orthodox and well-balanced" (Tow 1988:39). John Sung's preaching "always centered on the Cross" (Lyall [1954] 1965:x). He denied the Social Gospel but preached "the old Gospel of the Cross" (Lyall [1954] 1965:51). He strongly disagreed with evangelism through social methods or liberalism. He held firmly to one thing only, Jesus Christ and salvation from sin (Toktaeng 1984:110). He emphasized that Jesus came to save sinners (Sung [s a], 1:10-11) and that he died for sinners (:16-17). When a person repents of his/her sin, the blood of Jesus Christ can certainly cleanse him from sin (:23).

4.4.4 Prayer

John Sung was also a man of prayer. He prayed very early in the morning for two to three hours every day (Lyall [1954] 1965:xix). He believed in the power of prayer. Therefore he prayed intercessory prayer for thousands of converts (Tow 1988:43). He understood that “[p]rayer increases our faith” (Sung [s a], 2:12) as well as “our weapon, our cannon to fight Satan.” We can conquer the demon by prayer. Undaunted prayer is effectual (Sung [s a], 6:16). Prayer with hope is powerful (:17).

4.4.5 Regeneration

“To be born again is of [the] greatest importance” for humanity. To be born again is “something that must be vividly experienced” (Sung [s a], 2:5). He stressed that to be born again is to be understood and experienced by all. “The new birth is the foundation of doctrine. The new birth is [our] passport to heaven” (:6). Being born again is “the work and seal of the Triune God, Father, Son and Holy Spirit” (:7). If a person is not born again, that person does not have everlasting life (:10).

4.4.6 Holy Spirit

John Sung was most interested in the work of the Holy Spirit. He did not rely on natural gifts but relied on power from the Holy Spirit (Lyall [1954] 1965:ix). He shared his own experience of Nanchang on 5 March 1931 (Sung [s a], 3:16-17):

I was greatly discouraged in the first three years of my ministry... It was at Nanchang one night when God said to me, “From tonight, the Holy Spirit will accompany your labours.” From that time onwards the glory of God has been manifested everywhere.

“Divine power in no small measure was poured upon him” (Tow 1988:39). The Holy Spirit brings power, cleanses sins and gushes with living water (Sung [s a], 5:25). When man repents, God will make the person “a river of living water” (:26). He affirmed that “[e]very Christian should have the baptism of the Holy Spirit” (Sung [s a], 7:21). He was convinced that a Spirit-filled man need only lay hands on the head of one who had truly repented and had his sins cleansed to bring the Spirit down upon him (Sung [s a], 7:16; Lyall [1954] 1965:173). It was not

enough to be filled with the Spirit. We need to stand firmly on the foundation of God's Word (Sung [s a], 7:17).

Timothy Tow asserted (1988):

During all the 15 years of John Sung's ministry, there was not a single place where he ministered that the Holy Spirit had sent the gift of tongues (:54). His ministry brought no tongues in confusion but many tears in confession (:58). [W]hen [the] so-called Holy Spirit Churches in North China demanded to speak in tongues as proof of a needed second blessing when their members had never bowed the knee in repentance of their sins to God, John Sung reputed them. Without sin being washed out from within, there was no possibility of the Holy Spirit filling them. The prerequisite of a filling of the Spirit is the cleansing of sins from our lives. (:54).

He did not agree with the idea of the second blessing. He said that it was not necessary to speak in tongues, to see visions (Sung [s a], 7:8). He was not Charismatic or Pentecostal at all.

There is relationship between Holy Spirit and humanity's sin. "Unless sin in the heart is cleansed by Jesus' precious blood through prayer, the Holy Spirit will not fill us" (Sung [s a], 7:16). The Holy Spirit cannot fill us when we are unholy (Tow 1988:54-55). "An unholy person has no power" (Sung [s a], 6:9). On the other hand, when we have power from the Holy Spirit we have power in witnessing (Sung [s a], 7:12) and, conversely, if "we do not witness we are not filled with the Spirit" (Sung [s a], 7:24).

He taught the work of the Holy Spirit as follows (Sung [s a], 7):

1. Without the Holy Spirit in the heart, one has no knowledge of sin (John 16:8)...
2. Without the Holy Spirit, we cannot understand our Bible-reading (John 16:13)...
3. Without the Holy Spirit we can hardly pray (Rom. 8:26,27) (:1)...
4. Without the Holy Spirit we have no faith (I Cor. 12:9)...
5. Without the Holy Spirit, there is no love (Rom. 5:5)...
6. Without the Holy Spirit, there is no courage (Mark 13:11)...
7. Without the Holy Spirit, there is no power (Acts 1:8) (:2)...
8. Without the Holy Spirit, there is no fruit (Galatians 5:22)...
9. Without the Holy Spirit there is no life (Gal. 5:25)...
10. Without the Holy Spirit there is no unity (Eph. 4:3)...
11. Without the Holy Spirit there is no holiness (I Pet. 1:2)...
12. Without the Holy Spirit there is no submission. Without the filling of the Holy Spirit, one is not holy and one cannot submit to Jesus...

13. Without the Holy Spirit there are no gifts (ICor. 12:7-11)...

14. Without the Holy Spirit, there is no proof (Eph. 1:13, 14) (:3)...

What the Church needs, what every member needs, is the Holy Spirit (:4).

To acknowledge and to know the work of the Holy Spirit is the beginning and the end of a Christian's life. The Holy Spirit transforms us into powerful and submissive children of God.

4.4.7 Sanctification

John Sung preached that we must be separate from the children of the world in holiness (Sung [s a], 2:16). On one occasion he preached as follows (Sung [s a], 3:10):

Even our body is the temple to the Holy Spirit. Though we are of little worth, God wants us to become holy. To become holy is to become a holy temple. Let us seek holiness early that God might dwell in our hearts.

God will bless and use a holy person. God gives power to heal the sick to a holy person. But humanity can be holy only by the word of God (Sung [s a], 3:19). Thus, he "strongly emphasised the holiness of God" (Tow 1988:39).

4.4.8 Church

John Sung's doctrine of the church was sound. "While he was not slow to rebuke modernist ecclesiastical leaders, he loved the people and worked with the church, having been nurtured in a parsonage from birth to manhood" (Tow 1988:39). He was probably an individualist, but he never lost sight of the corporate nature of Christianity. "Being unhampered by denominationalism, he went wherever the churches invited him. He worked with them and through them" (Lyll 1965:xi). He accepted invitations from all kinds of churches, that is, big and small churches and town and village churches (Tow 1988:56).

He did not regard the mode of baptism as important. Timothy Tow (1988:40) declared:

As to the mode of baptism, he naturally sprinkled. This he did to a batch of two hundred at their request while campaigning in Manchuria. In Hong Kong, however, he went under the water in a Baptist Church to identify himself with the Baptists, and for the sake of gaining entrance to

Baptist territory. Now that he was immersed, the missionary of that Church asked him to baptise twenty-one women and twelve men, which he did.

John Sung described the need for the church as follows (Sung [s a], 6:22):

Now, why the Church? It is in order that united we might provoke one another to love, to run the heavenly race. This brings progress. But [it is] not for a born-again person to run alone. Then he will cool off. Not so when we are in a fellowship, whereby we are more and more encouraged and kept and helped through fellowship. So members of the same Church should help one another, keep one another, preserve one another. Without the Church, one is left alone to eventual falling away.

He never supported the division of the church. He encouraged people to unite together in Christ (Lyll [1954] 1965:125-126). He "comments in his journals that the existence of numerous denominations of foreign origin is one of the greatest hindrances to the spread of the gospel in China" (:117).

4.4.9 Eschatology

John Sung was a Dispensational Premillennialist. Timothy Tow (1988:39) asserted that "[t]hough the Bible was his only textbook, John Sung could have used a Scofield Reference Bible, as reflected in the dates of authorship and other dates in his Homilies on the whole Bible. If he had consulted the Scofield Bible, he did not show any trace of Dispensationalism in his teachings." The Scofield Reference Bible which was edited by Cyrus Ingerson Scofield (1843-1921), was published in 1909. "[I]t rapidly became the most widely received defense of Dispensational Premillennialism... Scofield believed that the Bible, when interpreted literally, was clear in its divisions and plans for Jews, Gentiles and the church" (Whiteman 1990b:1057-1058). But Timothy Tow's understanding of John Sung's Chiliasm is not true. John Sung preached "Mark, Haggai, Obadiah, and 2 Timothy" (Sung 1995b:277) at the Maitrichit Church in Bangkok from July 22 to August 2 1939. His sermons on Mark were published in Thai. When he preached on chapter thirteen of Mark, he interpreted it as follows (O.M.F. 1962):

There are seven signs that will happen before the end of the world. From the time that Jesus came to this time is seven times or periods. There are seven signs.

The first period was from AD 30 to 70. In verses 5-6 Jesus said let no man deceive you...testing by the eye. The eyes of Christians and of the church need to be tested... We can call it the first test.

From the time Jesus ascended to heaven till AD 70 the church was tested and people were divided into two groups (:130).

The second period is in verses 7-8, testing by the ear. From AD 70 to 100 there will be wars (131).

The third period is in verses 9-11, testing by the mouth. From AD 100 to 200 the mouth must be tested, not eyes or ears (:133).

The fourth period is in verses 12-13, testing by hands and feet. That is, there will be strife in the family, fathers killing sons and sons fathers. Christians will be hated by those in the house who are not Christians, not others persecuting them but our own brothers and sisters and relatives persecuting us (:134)...AD 200-323. There were great splits in the church till AD 323...

The fifth period is in verses 14-20, testing by the brain from AD 325 to 1517 (:135).

The Dark Ages till the time of Martin Luther (:136).

The sixth period is in verses 21-23, testing by the spirit from AD 1517 to the present day (:139).

The seventh period is in verses 24-27, testing by death. Everything is dark, the sun is dark, everything is dark, and there is no light. The world is in darkness (:140).

Even though the understanding of the seven dispensations of Scofield's are different from that of John Sung, we can find John Sung's viewpoint of Dispensational Premillennialism in his sermons. He said, "[d]eath does not end all" (Sung [s a], 6:3). "I know when Jesus returns this world will be destroyed. At that time we will be caught up to meet with Him in midair. When Jesus returns the Jews will rule this earth!... We'll reign with Christ 1,000 years" (Sung [s a], 8:6). "After the millennium this world will be annihilated. Then will succeed the age of a new heaven and new earth" (Sung [s a], 8:11). He maintains a clear distinction between the church and Israel.

John Sung emphasised "the soon coming of Christ" (Tow 1988:39) and the temporality and vanity of this world (Sung [s a], 3:21). But he had a sound eschatological world-view. He continually said, "[t]his world is not my home, I'm just passing through... But this does not teach us to get out of the world, to neglect our earthly duties. Rather we should have a clear perspective of the world so that we may not be encompassed and subdued by it. Though we are in the world, we are not of the world" (Sung [s a], 3:21-22).

4.4.10 Homiletics

In his book, *I remember John Sung*, William E Schubert (1976:14), veteran missionary to China and John Sung's close friend, gave an appraisal of John Sung:

Dr John Sung was probably the greatest preacher of this century. I have heard almost all the great preachers from 1910 until now, including R A Torrey, Billy Sunday, Henry Jowett, the great holiness preachers, the Methodist bishops, including Bishop Quayle, even Harry Emerson Fosdick, who set a great example of the homiletic art,...., and finally Billy Graham. Yet John Sung surpassed them all in pulpit power, attested by amazing and enduring results.

John Sung's "preaching was essentially expository and Biblical... Nothing mattered to him but to declare the Word of God" (Lyall [1954] 1965:192).

John Sung's sermons had fervour. The Rev Samuel Kho (1999) testified that "Dr Sung preached most vigorously, he really poured himself into it, using all his body. He was wearing a white shirt and it was soaked, all of him was soaked, perspiration just ran off him." "He was on fire for God, 'a living flame of gospel zeal'" (Lyall [1954] 1965:ix). This zeal of a man on fire attracted the multitudes (Lyall [1954] 1965:192). John Sung used everyday words in his preaching. "John Sung, above any other Chinese preacher, could speak the people's language, to both old and young, to the educated and the uneducated, to ancient women and underage children" (Tow 1988:42).

John Sung ([s a], 2:18) preached allegorical sermons from time to time. Here is an illustration of his allegorical preaching on Gn 6:14-22.

The boat Noah made was rectangular: length 300 cubits, width 50 cubits and height 30 cubits. It looked rather like a Bible. And the Ark is a type of Bible. There are three storeys with a window on top. The Bible is divided into three sections: 1) the Old Testament, 2) the Four Gospels and 3) the Epistles. Revelation is the window on top. The boat has only one door. To enter the Kingdom of Heaven there is also only one narrow door. The whole Ark is made of one type of wood. The whole Bible is written by inspiration of the Holy Spirit. The Ark's length is 300 cubits inasmuch as Jesus' life span on earth was thirty years. Three storeys also stand for Jesus' three years of preaching. The window on top stands for the last year of Jesus' work, and it also typifies the Cross.

When he preached at Maitrichit Church in Bangkok from July 22 to August 2 1939, he also interpreted the Bible allegorically (O.M.F. 1962:78):

Jesus broke five loaves and two fishes to feed five thousand people. This signifies five continents. Jesus died on the Cross that the whole world may feed on Him. From the five loaves and two

fishes there were twelve baskets left over, which signify twelve families or clans. Whatever Jesus did, he wanted His disciples to do likewise. The seven loaves are the seven churches, the four thousand to whom they were given are the four directions, meaning the whole world. Jesus died for us, gives us life, and so we must give it to the whole world, this is the spiritual meaning.

“[H]e was able to hold his audiences and give them a familiarity with the contents of Scripture" and yet his interpretation of the Bible was "often fanciful in the extreme" (Lyll [1954] 1965:145). He preached that heaven is in the north where there are no stars. Hell is in the centre of the earth where there is hot fire (Sung [s a], 1:5).

His preaching was demonstrative in style. “[H]e used many visual aids of his own innovation." He would *perform* his sermon in the pulpit. One time he wore "the rags of a Chinese gown to represent sin and a linen-white one for our righteousness in Christ. For the Holy Spirit he would use a little bell which he rang vigorously to show a born again person is disturbed by sin under conviction" (Tow 1988:42-43). The Rev Samuel Kho (1999) who attended John Sung's meeting at Maitrichit Church in Bangkok in 1938, has recollected John Sung's preaching style vividly:

I can remember clearly that that day he said he was preaching about sin and the burden, bearing the burden of sin. He took a sack the size of 100 Kgs of paddy rice and carried it on his shoulder, preaching for all of two hours. There weren't just ordinary things in that sack, but a stove for cooking rice, a ladle, food, rice and many different things, all of them heavy. He carried it about and preached like that. He carried it till it was very heavy and his shoulder must have hurt... And he said, "What is it that makes it heavy?" And then he lifted out the stove and the ladle. And he had laid everything down. He was not taking it back, he was giving it to God, but when he went home he would take it home. That is to say, he was demonstrating that everyone wants to escape from the heavy weight of this world. But in the end, after praying, after setting everything down, when they go home they take it with them again; they carry it again and do so all their lives.

John Sung was "a man who put himself and Christianity into the news by his unorthodoxy ways, which always annoy the orthodox" (Lyll [1954] 1965:157). He was “[n]oisy and acrobatic and full of humour on the platform" (:xxii).

John Sung employed music in his preaching. In "every message he preached he would have an appropriate chorus to sing at intervals" (Tow 1988:43). John Sung "gathered many wonderful testimonies and illustrations which he used most effectively in his sermons" (:45). He also used "numerous references to his own personal experience as a Christian" (Lyll [1954] 1965:154).

4.5 John Sung's impact in Southeast Asia

In the interpreter's preface of *The diaries of John Sung: An autobiography* (Sung 1995a:ii) Stephen L Sheng said “[i]n the few biographies of John Sung in existence, there has been no comprehensive and authoritative record of his most productive ministry years and his illness and death.” In his book, *John Sung*, Leslie T Lyall ([1954] 1965:xiii) mentioned that John Sung's own publication, *My testimony*, was the basic source of the book up to 1934. Also Leslie T Lyall said that “[t]he chronology of the story after 1934 is sometimes uncertain and may in some instances be faulty” (:xiv).

John Sung's itinerant preaching ministry began in the Philippines in 1935 and his work overseas continued until the beginning of 1940, except for 1937. The exact information regarding John Sung's ministry abroad could not be found before 1994. Fortunately John Sung's own Chinese diary, entitled *The diary of his spiritual life of Dr John Sung* (靈歷集光:主僕宋尚節博士的日記摘抄), was published in 1995 by his second daughter, Levi Tian-Zhen Song, in Hong Kong, by Eng Yu Evangelistic Mission. The translated English edition of the book was published in America in 1995, entitled *The diaries of John Sung: An autobiography*, by Stephen L Sheng without the name of the publishing company. It is no exaggeration to say that the English translated version of John Sung's diary, *The diaries of John Sung: An autobiography*, is the best source for John Sung's ministry in Southeast Asia.

First an analysis will be given of John Sung's ministry in Southeast Asia, and then his ministry in each country will be evaluated briefly. At the end the long-lasting impact of his ministry in Southeast Asia will be delineated.

4.5.1 An analysis of John Sung's ministry in Southeast Asia

Table 4 below shows detailed statistics of the countries in Southeast Asia visited by John Sung from 1935 to 1940 even though it looks somewhat complicated. The statistics need to be opened to the public because we find authoritative source material only from *The diaries of John Sung: An autobiography* (1995a:57-171).

Table 4. Detailed Statistics of the Countries in Southeast Asia Visited by John Sung between 1935 and 1940³³

Country	Places	Period of Meetings	No. of Partic. 34	No. Saved ³⁵	No. Dedicat. for Full-time Serv. ³⁶	No. of Ev. Teams Formed ³⁷	No. Healed ³⁸
Philippines	Manila	From end of May to beginning of June 1935	700-800	657			
Singapore	Singapore	28 Aug~13 Sept 1935		1,363	70-80		
Malaysia	Malacca	13 Sept 1935~? ³⁹					
	Penang	?		564	33		
	Sitiawan	30 Sept~8(?) ⁴⁰ Oct 1935					
Indonesia	Medan	9~18(?) Oct 1935	300-400				
Singapore	Singapore	18~26 Oct 1935	2,000				
Hong Kong	Hong Kong	?(Short time)					
Taiwan	Taipei	15~23 Apr 1936	1,200+			149	
	Taizhong	23 Apr~1(?) May 1936	2,000	1,700	139		
	Tainan	1~9 May 1936	4,600	4,063	335	244	
	Total		7,000~8,000				
Hong Kong	Hong Kong	14~25 June 1936				50	
Singapore	Singapore	15~19 Sept 1936					
Malaysia	Sibu	21 Sept~2 Oct 1936		1,500			
	Sarikei	2~13(?) Oct 1936					
	Bandar Maharani	13~20(?) Oct 1936					302
	Kuala Lumpur	20~27(?) Oct 1936					
	Klang Island	27 Oct~2(?) Nov 1936					
	Penang	3~10(?) Nov 1936	400+	100+			
Burma	Rangoon	12~18 Nov 1936	500				50-60 41
Malaysia	Sitiawan	22 Nov~2 Dec 1936					287
Singapore	Singapore	3~22 Dec 1936					238
Hong Kong	Hong Kong	13~18 May 1938		117		21	164
Vietnam	Hanoi	20 May ~?		107	55	38	
	Saigon	?	600	472	118	161	
	Saigon Chinese Church	?	200~300	370		20	156
	A city in central Vietnam	?~18(?) June 1938	400~500	456		90	366
Thailand ⁴²	Maitrichit Church, Bangkok	End of Sept 1938~?		300			
	Bangkok	7		153			
	Sathom Church, Bangkok	?(for three days)		63		15	
	Nakhonpathom	?		163			
	Trang	?~ before 5 Nov 1938		183			
Singapore	Singapore	5~15 Nov 1938		463	87	51	262

³³ The following statistics are drawn from *The diaries of John Sung: Autobiography* (tr by S L Sheng) 1995:57-171. All detailed statistics of the facts are not given. The writer includes information found only in this book. When the statistics of the translated English edition differ from the original Chinese copy, the writer chooses the statistics of the original one.

³⁴ The average number of attendees at the meetings. Sometimes numbers are of daytime or evening time only.

³⁵ The number of people who repented and accepted Jesus Christ as their personal Saviour.

³⁶ The number of people who dedicated themselves for full-time service.

³⁷ The numbers of evangelistic teams formed.

³⁸ The number of the sick for whom John Sung prayed.

³⁹ The meaning of the question marks are not clear.

⁴⁰ The date is not correct but we can trust the date with an average error of one or two days. John Sung spent the time moving from place to place.

⁴¹ The number of people who gave testimonies of healing.

⁴² The name of the place based on the interpretation of Winnie To from the original Chinese copy.

Table 4. Detailed Statistics of the Countries in Southeast Asia Visited by John Sung between 1935 and 1940

Country	Places	Period of Meetings	No. of Partic.	No. Saved	No. Dedicat. for Full-time Serv.	No. of Ev. Teams Formed	No. Healed	
Malaysia	Bandar Penggaram	16(?) Nov 1938~?		214	30	15		
	Seremban	?		404		31		
	Penang	?		366			108	
	Taiping	?	300	156		14		
	Sitiawan	?	600	494	72		280	
	Ipoh	?		154		22		
	Segari	?(4 1/2 days)		232		19	64	
	Kuala Lumpur	?~13 Jan 1939		348				
Indonesia	Surabaya	13 Jan 1939~?		652		54	377	
	Magelang	27 Jan ~3 Feb 1939	300			20+		
	Surokarta	4 ~ 11 Feb 1939		317				
	Bandung	12~19 Feb 1939		289				
	Jakarta	20 Feb ~ 2 Mar 1939		800+		46	500	
Singapore	Singapore	3 ~ 8 Mar 1939	1,000	339			161	
Singapore	Singapore	18~23(?) May 1939						
Thailand ⁴³	Chiangmai	25 May~2 June 1939	3,000~4,000	848	50			
	Lampang	3 ~8 June 1939		302				
	Chiangrai	9~15 June 1939		466				
	Phrae	16~22 June 1939		324				
	Nan ⁴⁴	23~29 June 1939				32		
	Phitsanulok	30 June ~2 July 1939		171		20		
	Phetchaburi	7~12 July 1939		109	33			
	Nakhonsi-thammarat	13~18 July 1939		221		21		
	Trang	18~20 July 1939		95		30		
	Bangkok	22 July~2 Aug 1939	700+	156	42			
	Total	2 months and 11 days ⁴⁵		3,000			285	1,500
	Indonesia	Bogor	12~18 Aug 1939	2,000	970			
Tjirebon		19~25 Aug 1939	800	785			503	
Semarang		26 Aug~2 Sept 1939	1,400	1,239			700	
Jokjakarta		3~11 Sept 1939	2,000	808			400	
A nearby town of Jokjakarta		11~19(?) Sept 1939	400	519 ⁴⁶	47			
Surabaya		19(?)~3(?) Oct 1939	2,600	1,400	140		1,700+	
Makasar		3~15 Oct 1939		859	100			
Ambon Island		17~30(?) Oct 1939	1,100	675				
Makasar		3~6(?) Nov 1939						
Surabaya		6~12(?) 1939						
Singapore	Singapore	13~19 Nov 1939						
Malaysia	Bentong	20~27 Nov 1939						
	Klang Island	27 Nov~4 Dec 1939						
	Penang	4 Dec 1939~4 Jan 1940						
Singapore	Singapore	4~8 Jan 1940						

The statistics show the countries and places visited by John Sung, the period of meetings, the number of attendees, the number of saved, the number of the dedicated people for full-time

⁴³ The name of the place is based on the interpretation of Winnie To from the original Chinese copy. Some of the periods of meetings could not be found in the original Chinese copy but could be found in Thai and English materials in Thailand.

⁴⁴ John Sung wrote the name of this city in Chinese "Seorai." It is "Nan" according to trustworthy evidence from Thai and English material.

⁴⁵ The total dates given here of John Sung's stay in Thailand, i.e. from 25 May to 2 August 1939, fall short by 2 months and 11 days. This is because John Sung arrived in Bangkok before 25 May 1939 and went up to Chiangmai by train.

⁴⁶ The number of saved people is more than the number of the attendees of the meetings. Probably John Sung would add the number of the repentant every day.

ministry, the number of evangelistic bands formed and the number of the sick who attended healing services.

"The first invitation from outside Dr Sung's own country came from the Philippines in 1935" (Lyll [1954] 1965:142). John Sung visited nine different countries in Southeast Asia. They were the Philippines, Singapore, Malaysia, Indonesia, Hong Kong, Taiwan, Burma, Vietnam and Thailand. According to statistics from Table 4 it can be seen that some countries were visited many times, for example, he went to Singapore nine times and to Malaysia five times. On the other hand John Sung visited the countries of the Philippines, Taiwan, Burma and Vietnam only once.

John Sung preached in only one city in Singapore and Hong Kong because those two countries are city countries. It can be seen in Table 4 that John Sung only stayed in Manila City while he was in the Philippines (Sung 1995a:57-58). But Leslie T Lyll comments that he made a visit to Cebu City too ([1954] 1965:144). John Sung preached in many different places in countries like Thailand, Indonesia and Malaysia. Generally speaking, he visited big cities rather than small cities in a country.

The periods of meetings were varied. Sometimes John Sung stayed at a place for a short time and sometimes he stayed for a longer time. John Sung just passed through Hong Kong and spoke at the Assembly of God Church in 1935 (Sung 1995a:67). When he visited the Trang Church in Thailand in 1939, he had meetings for only two and a half days (:157). However he stayed in Penang, Malaysia for a month from 4 December 1939 to 4 January 1940. This was because he was treated for anal *fistulae* by doctors while staying in the house of Mrs Hu. He also led many meetings in Penang (:166-168). Usually he remained at a place for a week's ministry. Sometimes he stayed at certain places for ten days (:147), but rarely more than two weeks (:60, 99-101).

Generally speaking, most of John Sung's audiences were of the Chinese diaspora in Southeast Asia. Millions of Chinese who were either born in different countries in Southeast Asian countries or who came from China could be found in those areas. "Those who were already Christians [in mainland China] carried their faith with them and set up Christian communities wherever they went... They always maintained a close link with the mainland." (Lyll [1954] 1965:141-142). Some of the audiences were the native people of those countries (:168).

John Sung "had a prodigious memory" (Lyall [1954] 1965:143). He was a genius and an excellent scientist. At the same time he was very diligent in writing his diary. His father kept a diary. It was from his father that he had acquired the habit of keeping a diary all through his life (Sung [s a], 4:2). He kept his diary without fail even during sickness (Sung 1995a:166). He said on 12 February 1941, "I don't want to interrupt my diaries which I've kept for 5,000 days" (:172). He wrote the statistics of his meetings day by day in his diary. To sum up, it is our conviction that we can trust the statistics of his diary.

The number of attendees differed from place to place. There were about 4,600 people in Tainan, Taiwan on 2 May 1936 (Sung 1995a:77). When he went to Chiangmai, Thailand in May 1939, the audience numbered 3,000-4,000 (:154). He spoke at a Westerner's church in Manila, the Philippines on 6 June 1935, and only about 80 attended the meeting (:57). Normally there were at least several hundred people gathered together and in many cases he had 1,000-2,000 in attendance.

Since John Sung's experience in Nanchang, China on 5 March 1931, "[h]e was to attack the strongholds of sin in the human hearts" (Lyall [1954] 1965:61). "Mercilessly he exposed the sins of unbelievers and professing Christians alike" wherever he goes (:62). His messages brought many people to repentance. "His preaching was simple, but simply powerful, **Spirit-filled...Only** the pure Word of God spoken in power" (Tow 1988:107). John Sung, "with regretful memories of his wasted years in America preaching the '**Social Gospel**', spoke faithfully about the power of the Blood of Jesus, the efficacy of the Cross, the necessity of the new birth and the importance of being filled with the Holy Spirit" (Tow 1988:58). "In every place there were deeply moving scenes as the Holy Spirit convicted men and women of sin" (Tow 1988:151). John Sung also emphasized the holy lives of the Christians in his sermon (Sung [s a], 3:17-19). It is clear from Table 4 that the more attendees there were, the more repentance occurred at the meetings.

John Sung's highly dedicated personality (Lyall [1954] 1965:viii-ix) made him deliver very devout messages to the hearers. It made many people dedicate themselves for full-time ministry. In Singapore, the Golden Link Bible School for training young Christians who dedicated their lives to God for full-time service was founded by Miss Leona Wu and Miss Ng Peck Luan on 14 May 1937 (Lyall [1954] 1965:168). We can see from Table 4 that many of the young generation offered themselves to God for full-time service in many countries.

John Sung also laid much stress on evangelism. He preached that “[s]ouls are most important... God regards the souls of ten righteous men more precious than the whole world” (Sung [s a], 3:6). “If we are truly born again we must lead many relatives and friends to Christ” (Sung [s a], 5:30). He understood that an eagerness for evangelism is the evidence of a born again Christian. Also he asserted that if a true Christian does not preach the gospel, he has no peace (Sung [s a], 6:7). Timothy Tow (1988:32, 52) testifies that John Sung mobilised “preaching bands” consisting of two or more to form a band and pledge to God to go out witnessing for Christ at least once a week, especially on Sunday afternoons. Every place where he went, evangelistic teams formed without exception. Two hundred and eighty-five preaching bands or evangelistic teams were organised in Thailand only in 1939 (Sung 1995a:157).

As far as John Sung's healing ministry is concerned, Leslie T Lyall stated ([1954] 1965):

[W]ithout making any claim to a "gift of healing," he made it a practice to include a service of healing at the end of most of his campaigns, when he used the occasion to preach the gospel. Where there was both repentance from the sin and a genuine faith in God's power to heal, there were often remarkable cases of healing. But there was also a large percentage of sufferers who derived no benefit at all (:133).

Healing itself was not his first priority but was valuable for evangelistic opportunities (Lyall [1954] 1965:137). His main concern was to bring sinners to repentance and faith. All the sick who wanted to be prayed for by John Sung had to submit “a record of their names and addresses and the nature of their disease on cards provided” (Lyall [1954] 1965:133) so that he could count the number of people accurately. John Sung “first helped them to thoroughly confess their sins.” Then he would anoint them with oil and lay hands on them and pray for them (Sung 1995a:100). Many kinds of illnesses were healed. Various kinds of ailment included, deaf-mute (:58), cripple (:64), lunatic (:91), demoniac (:104), hunchback (:111), skin disease (:150), nearly dead person surviving (:159), blind (:161), leper and opium addicts etc (:162). A brother Lin reported “some were completely healed, some half healed and some not healed. However, with my own eyes I saw a pile of crutches and sticks in front of the changing rooms” (:112). We find numerous personal healing testimonies in *The diaries of John Sung: An autobiography* (:57-171).

In summary, John Sung visited nine countries in Southeast Asia. In some countries he preached only in one place. On the other hand he preached in many places, most of them big cities, in some countries. Periods of his itinerant preaching ministry were varied among the Chinese

diaspora in many cases. Many Chinese and some of the local populace attended his campaigns. Many repented and offered themselves as full-time workers. Many evangelistic teams were formed in every place. Quite large numbers of people were healed even though the aim of a healing service was evangelistic. John Sung's campaigns became a real revival movement in the area of Southeast Asia in 1930s, especially among the Chinese. It is believed that a reviving strength was poured out upon the churches in the countries of the whole Southeast Asia area.

4.5.2 A brief evaluation of John Sung's ministry in each country

The total time of John Sung's ministry in the countries in Southeast Asia is about one year and seven months (Sung 1995a:57-171). John Sung began his itinerant ministry in the Philippines in 1935 for the first time (Lyll [1954] 1965:142). He visited five different countries during two months and three weeks in 1935. In 1936 he spent four months and two weeks in five countries. But the outbreak of war with Japan prevented John Sung from any visits overseas from January 1937 to April 1938 (Lyll [1954] 1965:161). He made a visit abroad for four months and two weeks in 1938 and for seven months and two weeks in 1939. He could work for only one week in Singapore in 1940 (Sung 1995a:57-171). That was the last of John Sung's ministry outside of China, as the chronic disease, anal fistulae, of several years duration was causing profuse and continual bleeding. When he accepted a speaking engagement at the Grace Church in November 1940, his old ailment flared up and became worse every day. After that he underwent operations from time to time (Sung 1995a:183, 188, 190). It was impossible to wholeheartedly serve the Lord publicly, even within China, from December 1940 until his death in August 1944 (Sung 1995a:188-226).

Table 5. Summary of John Sung's Visits

Country	Number of Times	Total Period
Singapore	9	2 months and 3 weeks
Malaysia	5	4 months and 2 weeks
Indonesia	3	5 months
Hong Kong	3	3 weeks
Thailand	2	3 months and three weeks
Taiwan	1	1 month
Vietnam	1	1 month
Philippines	1	2 weeks
Burma	1	1 week

Before we look at the visits of John Sung in each country, we can summarize the total period and number of times that John Sung visited various countries in Southeast Asia from *The diaries of John Sung: An autobiography* (Sung 1995a:57-170) in Table 5.

We know from Table 5 that John Sung visited Singapore most frequently, that is nine times. It is generally thought that Singapore is the place where the work of John Sung has "left the most permanent memorials in the form of organisation" (Lyll [1954] 1965:166). The Rev Timothy Tow (1985:223) asserts that "Singapore was his field headquarters by reason not only of its central location in Southeast Asia, but also of her kindred spirit toward him in Miss Leona Wu, his faithful interpreter and successor." Miss Leona Wu was not only the President of the Singapore Christian Evangelistic League, but also the Principal of Chin Lien Bible School. The one is the organisation of the preaching bands founded by John Sung, while the other was started by Miss Leona Wu for training the converts of John Sung's ministry in Singapore on 14 May 1937 (Lyll [1954] 1965:166). The Rev Timothy Tow shares his personal testimony in his book (1985:19-40), *John Sung my teacher*, as the witness of John Sung's campaigns in Singapore. He reflected on the past of John Sung's powerful preaching like this: "As the preacher thundered God's message with lightning effect upon a wicked city, the walls of resistance began to crumble" (Tow 1985:24). Many were saved. Chinese Bibles and English Bibles were sold out in less than a week, so that the Bible Society had to order large quantities of Bibles from Kuala Lumpur (Tow 1985:28). Many young people were consecrated to become full-time workers. Active preaching bands were formed. Miss Leona Wu was elected as the president of the preaching bands until 1974 (Tow 1985:32-33). John Sung had strong affection for Singaporean churches, more than for any other churches in Southeast Asia. Thus he sent three letters, dated 6 January 1941, 28 April 1941 and 9 October 1941, to the evangelistic teams in Singapore only. This was when he was on his sickbed (Sung 1995a:190, 192-196, 201-205). The Singaporean churches were truly revived (Tow 1985:7) and John Sung's ministry handed down influential church leaders to the churches. John Sung left indelible footprints among Singaporean churches.

According to Table 4 John Sung passed through Singapore whenever he paid a visit to Malaysia except the visitation from 22 November to 2 December 1936. When John Sung went to Malacca in Malaysia in 1935, pastor Lin did not welcome him. But pastor Lin was born again during the meetings. The power of the Holy Spirit was shown in many places in 1935 (Sung 1995a:61-63). Many of the sick were healed in 1938 (:91-95). The churches in Ipoh, Taiping, Sitiawan and Penang had great spiritual vigor resulting from John Sung's ministry in 1938. Nominal

Christians found Jesus Christ as their personal Saviour through the work of John Sung (Lyll [1954] 1965:166-167). John Sung was very sick and preached from his sofa bed but God's power was still with him while he was in Penang in December 1939 (: 166). It is obvious that the churches in Malaysia were revived by John Sung's campaigns.

From Table 5 there is no doubt that John Sung stayed in Indonesia for the longest time. Obviously from Table 4, John Sung could see the most people gathered together and saved in Indonesia. Most of his visits were made in Indonesia in 1939. Timothy Tow (1985:224-225) said regarding John Sung's ministry in January 1939 in Indonesia as follows:

The Dutch East Indies being of a Reformed background, they who inherited a formal and reserved culture were taken aback by John Sung's unorthodox style in preaching and praying which was uttered in a loud voice with everyone taking part. Nevertheless the power of the Gospel soon became its own credentials so that the audience adapted themselves to the preacher's ways without much difficulty...The Name of Jesus Christ was greatly magnified when these early morning meetings were fully attended because those Chinese who were shop keepers closed down their shops and came to church en bloc-to the amazement of everyone.

In Surabaya in 1939 the audience of at least five thousand came from many races and languages because John Sung preached "Jesus Christ and Him crucified, risen and coming again" (Tow 1985:227-228). The Dutch missionaries were amazed, and said that John Sung's campaigns in Indonesia were like the revival in Wales (Tow 1985:225). Some of the church leaders of the Dutch tradition in Ambon Island were against John Sung's laying hands on the sick (Tow 1985:228). John Sung's ministry in Indonesia was the most successful in regard to the numbers of people converted.

According to Table 5 John Sung visited Hong Kong only for three weeks altogether. He spoke at the Assembly of God Church when he was passing through Hong Kong around the end of October 1935 (Sung 1995a:67). John Sung was very sad when he saw a more deteriorated spiritual condition in Hong Kong than in Guangzhou in June 1936. His sermon topic was "The Church in Laodicea" (Sung 1995a:81). Before he headed for Vietnam, he stopped at Hong Kong on 13 May 1938. There was no ship for Vietnam so he held meetings at a school. One hundred and seventeen people were saved there, and twenty-one evangelistic teams were formed (Sung 1995a:137). It seems that Hong Kong was not John Sung's strategic place of ministry, but just a

spot through which he passed to another point. We cannot find any evidence that John Sung's campaigns had any big influence on the churches in Hong Kong.

As for John Sung's work in Thailand, it is not necessary to explain this in detail here, because it is described in Chapter 5 and Chapter 6. It is certain that his campaigns in Thailand brought a revival that was unprecedented in Thai church history, and a great work of the Holy Spirit unparalleled to this present time.

Table 4 shows that John Sung landed in Taiwan in April 1936. Taiwan was known as Formosa in the thirties (Tow 1985:193). Japan took Formosa from China in 1895 and returned it in 1945 (:194). Thus Taiwan was under Japanese control in 1936. John Sung's meetings were arranged in the three main cities: Taipei, Taizhong and Tainan. A week was spent in each place. About one thousand attended the meetings in Taipei. Many attendees of the meetings followed John Sung to Taizhong so the numbers of attendees there were doubled. Some went to Tainan and the numbers reached over four thousand. "Throughout the whole church there was a great revival of Bible-reading and public witness. Results in the shape of increased church attendance were spectacular. Numerous baptisms followed Dr Sung's departure" (Lyll [1954] 1965:150-151). "From the number of people saved and energised by the mighty working of the Holy Spirit, the Formosa or Taiwan campaign could well be termed another Pentecost" (Tow 1985:195). The campaigns brought unprecedented revival in Taiwan's history (Lyll [1954] 1965:152).

In Vietnam, John Sung preached in Hanoi first. Then he travelled to Saigon. He preached at "the annual convention of all the leaders of the Christian Missionary Alliance churches in south Vietnam" (Sung 1995a:138). Many were permanently blessed at the Chinese church in Cholon, a suburb of Saigon, and the church still witnessed in the fifties (Lyll [1954] 1965:163). John Sung himself testified that "[a]fter I left that country, I heard that the churches [were] really fired up, which inspired me to go [to] foreign places" and "witness to foreign peoples" (Sung 1995a:139). The numbers of converts through John Sung's ministry in Vietnam were not many compared with other countries. But it is commonly agreed that the churches there also experienced revival (Tow 1985:216; Lyll [1954] 1965:163).

Three churches in Manila, the Philippines, namely the Episcopal, the United Evangelical and the Christian Assembly Churches, issued the first invitation to visit Southeast Asia to John Sung. "Crowds gathered from all over Luzon and from other islands to attend the meetings" from 6 to

14 June 1935. Pastor Sila Wang of the Chinese United Evangelical Church recollected that "Dr Sung had one line of teaching: sin, repentance, the new birth, holiness" (Lyll [1954] 1965:142). "Out of this series of revival meetings a strong preaching band was organised" (Tow 1985:189). "There were lasting results from these meetings. The United Evangelical Church was greatly strengthened and its evangelistic zeal kindled. The evangelical band organisation which was formed at that time was still active in 1953, eighteen years later." John Sung's impact was not small in the Philippines as we hear from the report of a missionary in 1954. "So many of the true Christians in the Philippines are the direct result of John Sung's ministry" (Lyll [1954] 1965:143). "On the whole...the effect of this first overseas campaign does not seem to have been as great as that of subsequent campaigns among Chinese [people] overseas" (:144).

John Sung was invited by the overseas Chinese church in Rangoon. He rebuked the sins of the Chinese Church with zeal and boldness (Tow 1985:206). A large number of Indians attended and brought sick people with them. Though they could not understand Chinese, they believed Christ and were healed (:207). "As the crowds were limited so were the results; three hundred were converted and thirty preaching bands organised" (:206). It seems that John Sung's campaigns in Rangoon had the least impact of all the campaigns among the countries in Southeast Asia.

4.5.3 Long-lasting impacts of John Sung's ministry in Southeast Asia

It is commonly agreed that John Sung's ministry in Southeast Asia has had great lasting results. "In his comparatively short life he had left behind a profound and lasting impression on the churches everywhere in Asia, and long after his death in 1944 Christians still remembered him with both awe and affection" (Lyll 1985:33). As "a tree is recognised by its fruit (Mt 12:33)", a true revival is tested by its long lasting results. Thus, it is necessary to note the persisting results of John Sung's ministry in Southeast Asia, excepting Hong Kong and Burma. It should also be asked why John Sung's work bore lasting fruits.

In the preface to the fourth edition of *John Sung*, Leslie T Lyll ([1954] 1965:xv) presents a phenomenal list of converts and leaders that was recorded after a visit to the Far East in 1960. There were those whom Dr John Sung had trained, and who were making an impact for Christ in Southeast Asian countries more than fifteen years after John Sung's death.

In Singapore, Miss Leona Wu, Principal of the Golden Link Bible School, and the Rev Timothy Tow, the founder of the **Fareast** Bible College, are converts from Dr Sung's ministry. Many influential Christians were recipients of John Sung's ministry (Lyall [1954] 1965:xv-xvi).

In Malaysia, "some of the most active and energetic Christians are Sung converts" (Lyall [1954] 1965:xvi).

In Indonesia, John Sung's two evangelistic journeys in 1939 had profound influence in the entire Chinese community. "The Chinese churches owe their present vitality entirely to his powerful ministry" (Lyall [1954] 1965:xvii). "The Surabaya preaching band functions regularly every week" (Lyall [1954] 1965:xviii). The Principal of the Southeast Asia Bible College was a Sung convert. The Rev Gouw **Kwan-Yang**, the pastor of the largest Chinese church in Bandung, was converted by John **Sung's** ministry. It was possible to meet many Christians who were converted through John Sung's ministry not only in the area of Java, but also in the outer islands (Lyall [1954] 1965:xviii).

In Thailand, the Rev and Mrs **Lim Pu-yi**, who are John Sung converts from China and Singapore, maintain vigorous witnesses for Christ in Bangkok. Rev **Boonmark Getesarn**⁴⁷ who exercised a wide influence in the Thai churches owes much to the spiritual inspiration of John Sung. In north Thailand, Dr Pipat who is the head doctor of the Presbyterian hospital is another Sung convert in **Chiangrai**. Many Thai converted under Dr Sung's ministry are serving the Lord actively (Lyall [1954] 1965:xvi-xvii).

In Taiwan, Leslie T Lyall met an American missionary who was too young to have known John Sung. The missionary testified to Lyall that wherever he goes in Formosa he hears John Sung's name. He knew many influential Taiwanese Christian leaders who had come to believe in the Lord through John Sung's ministry (Lyall [1954] 1965:xviii-xix).

In Vietnam, Leslie T Lyall also found lasting results of Dr Sung's ministry. Dr Sung's memory is revered by many who came to new life in Christ during one of his meetings (Lyall [1954] 1965:xvii).

⁴⁷ In most cases his surname is written as Gitisarn. But sometimes Gitisan is used as well.

In the Philippines, there is a big Chinese community and "the large Christian high school in connection with the Westminster Church was started by three sisters all of whom were converted" through John Sung's ministry in Manila. Many of the older generation Christians still remember John Sung (Lyll [1954] 1965:xvii).

The question may well be asked, why did the fruits of John Sung's ministry last for such a long period of time? Of course we can sum up easily by saying, "[r]evival is God's sovereign work" (Edwards 1997:237) so that God, the author of revival, is the One who maintained the lasting results of John Sung. But that kind of answer is too general and cannot satisfy us. "God frequently uses particular men in revival...It is God's way" (Edwards 1997:46). "Those whom God uses in leadership in revival are always men who have met with God in a powerfully personal way and have a burning passion for the glory of God and a life of holiness" (Edwards 1997:48).

John Sung had met God in a powerfully personal way. He testified of his experience at the Union Theological Seminary in New York on 10 February 1927 (Sung 1977:77-79):

The heavy burden on my soul became heavier day by day. On the tenth day of February I got to the point where I simply had no desire to live...That evening I prayed earnestly and sincerely, with weeping, for the Lord's precious blood to cover me...As I prayed my sins were spread, one by one, before my eyes...I read the twenty-third chapter of St. Luke, about the Lord Jesus suffering for my sins...Jesus was already hung up high on the cross...I fell on the ground at the foot of the cross, crying to the Lord Jesus to wash me from all my sins in His precious blood...Then I heard a whisper saying, "Son, thy sins are forgiven"...Suddenly God the Father came in...and the Lord Jesus took His seat on the high throne of my heart...That night was my spiritual birthday, the night I can remember best.

John Sung had a burning passion for the glory of God only. He spoke of himself as "the least of the Lord's servants." "He resented rather than invited the praise of men" (Lyll [1954] 1965:192). He longed for a holy life (Sung [s a], 3:10).

The other reason why the results of John Sung's ministry endured for such a long time can be found in his prayer life. The Rev William E Schubert (1976:66-67), one of John Sung's best friends, testified as follows:

He had hundreds of prayer requests, even thousands, on prayer blanks... In order to have such a prayer interview with Dr Sung, each one of them must bring a prayer blank with name, address, sex, age, photograph, prayer requests, and a testimony. These represented never-dying souls, hearts open to His gaze... Dr Sung kept all these prayer blanks, and carried with him, thousands, in two big suitcases, and he would pray fervently for these people afterward, even while preaching three times a day and having many interviews, besides spending hours with the Word.

John Sung was "always up at 4.00 or 5.00 a.m. to spend hours on his knees reading his Bible and praying" (Lyll [1954]1965:173). He was a man of prayer. Because of this, "wherever John Sung had been, there were Christians who remained true and faithful" (Schubert 1976:67).

4.6 Summary and conclusion

John Sung maintained his particular disposition from his childhood to the end. He had a keen mind and was charismatic and eloquent from the beginning. He was influenced by his father in many ways. Like his father he was fond of reading books and keeping a diary. Above all things he had spiritual sense—more so than any of the brothers and sisters in the family. At first he studied Chemistry in America, but his field of interest changed and he went on to study Theology at the Union Theological Seminary. His rebirth experience in Christ became the turning point of his life and led to his confinement at Bloomindale Mental Hospital, where he experienced God in the real sense. That occurrence moulded him into the greatest evangelist in the history of the Chinese church. His **five** three-year periods were dramatic and a great denial for God's glory.

John Sung had strengths and weaknesses, but his virtues triumphed over his faults. God even used his defects to make him humble before God and humanity. His strong points were much more conspicuous than those of other people. Even though his dauntlessness made some people misunderstand him and regard him as a conceited person, his bold temperament was used to extend the kingdom of God.

John Sung was fundamental in his theology. He strongly objected to liberal theology and the Social Gospel. His conviction of the inerrancy of God's Word and the assurance of the power of the Holy Spirit drew a veil over his theological weakness of allegorical interpretations of Scriptures. **Christology** was at the centre of his preaching. His ecclesiology was exclusive on the one hand, and inclusive on the **other**. Exclusive, because of his emphasis on the self-reliance of

the Chinese church, and inclusive because he consented to the different forms of baptism and polity. His eschatology had the tendency of Dispensational **Premillennialism**. He preached expository sermons, but sometimes they were too allegorical. They had fervency, but his unorthodox ways of preaching made some people reject his teachings. Nevertheless, John Sung was one of the most powerful preachers of the twentieth century.

Many missionaries working in Asia constantly **find** the fruits that still remain from John **Sung's** itinerant ministry throughout Asia. God used John Sung throughout Southeast Asia and enabled him to develop thousands of strong Christians. His active ministry in Southeast Asia was limited to the years 1935 to 1936 and 1938 to 1939. He worked in Southeast Asian countries for only one year and seven months altogether. And yet within such a short period of time he shook the churches of the entire region. Literally thousands were saved through his mighty ministry. By the power of the Holy Spirit, John Sung's ministry opened doors to people from many different racial and theological backgrounds in Southeast Asia. His ministry brought true revival by the power of the Holy Spirit. The writer should like to conclude with part of the monumental inscription from the John Sung memorial tablet in Chin Lien Bible Seminary in Singapore, quoting from page 144/ 145 (Tow 1985). "Dr Sung Ph.D., the flame of God in the Far East, whose earnest devotion to his life-ministry of reprovng the church of corruption and apostasy brought wholesale repentance and Pentecostal revival throughout China and S. E. Asia."

Chapter 5. The revival movement in the Thai church

There is a dearth of written records in English on the subject of John Sung's campaigns in Thailand. Many of the materials presented here are from the Archives of Payap University, Chiangmai, Thailand. Both Thai and English sources were used. John Sung's diaries were published in Chinese (Sung 1995b), *靈歷集光 (主僕宋尚節博士的1995年摘抄)*, in Hong Kong, and were edited by Levi **Tian-Zhen** Song. This book was translated into English by Stephen L. Sheng in the same year that it was originally written in Chinese. It was entitled *The diaries of John Sung: An autobiography* (Sung 1995a), and was published privately in the United States by Luke H Sheng and Stephen L Sheng. Although it is an abridged version of the original Chinese, it has been of great importance with respect to first-hand records.

Several books covering John Sung's campaigns in Thailand in 1938-1939 were published in English and in Thai. The books written in English are as follows. The most comprehensive work is Jaakko **Mäkelä's** (2000:49-56) *Khrischak Issara: The independent churches in Thailand, their historical background, contextual setting, and theological thinking*. Jaakko **Mäkelä** condensed the general introduction, the characteristics, an evaluation of John **Sung's** campaigns and the Bible College controversy in eight pages. He approached the subject quite holistically. Alex Smith (1982:195-198) explained the general introduction and the impact and evaluation of John **Sung's** ministry positively in his book, *Siamese gold: A history of church growth in Thailand: An interpretative analysis 1816-1982*. In his book, *The unfinished mission in Thailand: The uncertain Christian impact on the Buddhist heartland*, Samuel Kim (1980:54-60) referred to John Sung's ministry as a spiritual preparation for the Second World War of the Thai church.

The books written in the Thai language concerning John **Sung's** ministry in Thailand are Herbert R Swanson's (1995:106-109) *History of the pastoral care of the Church of Christ in Thailand, Draft version* and Prasit Pongudom's (1984:82-88) *The History of the Church of Christ in Thailand*. Herbert Swanson evaluated the campaigns from a pastoral care viewpoint in the CCT positively as well as negatively but Prasit Pongudom assessed John **Sung's** ministry, by and large, negatively. The materials that relate to John Sung's campaigns are scattered. Moreover, the materials lack unity and accuracy. Fortunately, we have found the cassette tape records of the witnesses at the Archives of Payap University in Chiangmai, Thailand. Also the writer

interviewed several witnesses all over Thailand thereby gaining credence that John Sung's meetings were a genuine revival movement led by the power of the Holy Spirit.

This brief survey of materials dealing with John Sung's campaigns in Thailand in 1938-1939 indicates that the writers focused mainly on a general evaluation of the revival. Although Jaakko Mäkelä's account is more holistic, it contains only eight pages relating to John Sung's ministry. None of the other authors have analysed John Sung's ministry in Thailand in any depth.

5.1 Introduction

This chapter gives an account of John Sung's ministry in Thailand in 1938 and 1939. To pursue this aim, the forerunners of the revival movement, those who prepared the ground for John Sung's campaigns, will be described.

5.2 The precursors of the revival movement—preparing the ground for John Sung's visit

John Sung's campaigns were not the first revival movement in the Thai church. Before he came to Thailand in 1938 there were some forerunners who had intermittently laid the foundation for his revival movement in the Thai church.

5.2.1 Laos Christian Convention

Since the first Laos Christian Convention held in Chiangmai in 1903, all the other mission stations in the Laos Mission, i.e. Lakawn, Nan, Chiangrai, Phrae, held a Christian Convention in 1905 for the first time. The second Convention in Chiangmai was held from 30 March to 3 April 1904. Many delegates from many parts of the field, that is, Wiang Pa Pau, Chiangrai, Phrae, attended the Convention in Chiangmai (Denman 1904:62). This Convention spread to other mission stations in northern Siam from 1905. The first Christian Convention was held in Lakawn, old name of Lampang, from 16 to 19 February 1905 (Wilson 1905:24), in Nan from 12 to 16 April 1905 (Park 1905:48), and in Chiangrai from 27 to 31 March 1905 (Briggs 1905:93). Phrae's first Christian Convention was held from 3 to 5 November 1905 (Crooks 1906:13). This Convention became the annual Christian conference in each of the five mission stations in the Laos Mission.

The programme of the Christian Convention in each mission station followed the model of Chiangmai station for three to **five** days. The programme in the morning consisted of singing, devotional time and Bible study. In the afternoon they went out for evangelism and had games. In the evening there was devotional time and stereopticon views with non believers who were evangelised by Christians in the afternoon. They arranged the sports time in one afternoon. The school children gave a march and flag drill. The kinder-garden children were also involved in a programme. On Saturday morning they had discussion time around the questions from the question box which anyone who had a question might use. On Saturday afternoon they arranged a feast for the Christians and non-Christians of the villages. The programme reached the climax with Sunday morning service. After the sermon and baptisms, the communion service was held. There was a children's service on Sunday afternoon. They had a farewell service on Sunday night (Park 1905:48-50). In the beginning missionaries took the leadership but the national Christians took the initiative at a later stage.

The Laos Mission approached the northern Siamese holistically, using not only spiritual programmes but also arranging social events for the non-Christians for the purpose of evangelization. One can **find** the signs of revival among the Conventions. Margaret Wilson (1905:24) in Lakwan Station reported that "the Holy Spirit was present through" the programme. In Nan Station several backslidden members came back and "publicly confessed that they want to live for Christ" (Park 1905:50). The summary of the Laos Christian Conventions said that they "have given new inspiration of work to the people and encouragement to the missionaries, as well, strengthening the weak" (A convention symposium 1906:30). About one thousand people attended the second Chiangmai Convention. This number is striking when we compare it with the total number of communicant members of the Siam Mission which only had 478 members in 1905 after sixty-five years of mission work from 1840 to 1905 (Smith 1982:117).

The stations in the Laos Mission generally felt that they were "already at the beginning of a Laos revival" (Personal and otherwise 1907:4). The missionaries from the PCUSA in the Laos Mission received news of revival among the home churches and in other non-Christian lands in 1907. Their dearest wish was for revival and they called for preparation for the Spirit's work in the northern Siam field (The distinct missionary responsibility 1907:12). The Christian Convention of Chiangmai area in 1907 was held at Me Dawk Deng Church. One Friday evening Daniel McGilvary, the founder of the Laos Mission, preached. There was "a seeking for an outpouring of the Holy Spirit upon the coming meetings." Many Buddhists came to listen to the

whole session. Nearly one thousand people attended (McKean 1907:46). The Laos News testified that the mission "remarked on the revival of [the] presbytery in Laos" in 1908 (Meeting of North Laos Presbytery 1909:59). Charles H Crooks (1910:55-56) who mentioned the signs of awakening in northern Siam based his argument on "the great discontent of the non-Christian people with their own religion" and "the general discontent with the spirits." He asserted that "the most wonderful sign of awakening was the power that the Evangelists showed in their teachings."

There was a great awakening in the Bethlehem Church that was located nine miles to the south of Chiangmai City. The Rev D G Collins (1912a:60) reported:

I imagine I hear some one say, "What a revival you are having, that beats Billy Sunday." In some respects it is a great revival; there certainly is a great turning unto the Lord, but it means more than the ordinary revival in a Christian land under Christian influences...Almost the only extra services which have been held in connection with this awakening has been the service held in every new house after the people have consented to become Christians...[B]efore the service is held all the spirit charms, offerings and such must be removed. The good luck strings on the necks and wrists, from the oldest to the youngest, must be cut off and then the Christian service takes place.

The revival occurred because of an awful malaria epidemic (Collins 1912a:61). When the Rev D G Collins came to the Bethlehem Church about 1886, the church had only sixteen members (:62). In February 1912 he baptised 84 people which broke all past records for new converts in the Laos Mission (:63). On 24 May 1912 the church gave baptism to over 200 persons for two hours. The congregation numbered about 600 (Collins 1912b:89). "During the past thirteen months 253 adults have been received and 191 children baptised, making a total of 443 persons. It had been a year rich in blessing to Mr. and Mrs. Collins and the Bethlehem people" (Personal and otherwise 1913:15).

Since the Laos Christian Convention began for the first time in Chiangmai in 1903, the expectation of the revival increased in all five mission stations of the Laos Mission. Even though the peak of the revival in 1912-1913 at the Bethlehem Church had been caused as a result of endemic malignant malaria, the results were connected with the ten years of the Convention. It seems quite probable that the Convention contributed towards preparing the ground for John Sung's visit in northern Thailand in 1939.

5.2.2 Conference for Christian Workers

The first revival signs in the Siam Mission were found in the "Conference for Christian Workers" in Phetchaburi. George B McFarland says ([1928] 1999:106-7):

It was somewhat about this time that the little band of workers at Phetchaburi decided to venture on an enterprise hitherto unused in connection with the work in Siam. They called a Conference for Christian Workers, asking some of the strong Christians from elsewhere to assist in the program which was to last three days and nights—from Friday morning to Sunday night, closing with a Consecration service. The purpose of this Conference was two-fold; to develop a feeling of solidarity among the Christian workers assembled from different stations, and to quicken the members of the local church into a new spiritual life. In both of these purposes it was successful. The annual Conferences for Christian Workers were continued and furnished spiritual upliftment and refreshment for the Christian people, and many believers from the country groups made long journeys to attend these meetings, carrying back with them new ideas of worship and of service which set them on a higher plane of Christian living.

In his book, *Spread of the teaching in the middle of the 20th century*, Toktaeng (1984:8-9) explains the conference for Christian workers. Dr George B. McFarland set up a conference for Christian leaders and became the chairman of the Conference from 1905 to 1914. He then handed over the position to Thai Christians. In arranging the Conference he followed the example of Billy Sunday. He trained Christian young people, male and female, in speaking and leading meetings. Each conference chose a main topic. All the young people who attended the meeting took part in the programmes. Senior people like missionaries and Thai Christian leaders had a supporting role in running the meetings. There was an annual meeting of this nature at the Sriphimoltham Church, in Phetchaburi. Similar meetings were held in Bangkok. Thereafter Christian Conferences were held continuously in Bangkok for 20 years.

In May 1907 John Eakin and family were transferred to Phetchaburi for evangelistic work (Eakin et al 1955:70). He attended the Christian Workers' Conference in Bangkok in November 1907. "It was the most remarkable manifestation of spiritual power ever seen in Siam." His experience there changed his entire future ministry (:54):

In the very midst of a full program, a chain of prayer started, and it did not end till the floor was wet with the tears of penitence of those overcome with the conviction of sin. As a result of this experience, all John's plans were changed. He felt a special urgency to carry the Gospel to the

country districts, leaving the work of the town to other missionaries and national workers who could not get away.

There was a clear conviction of sin among the participants of the Christian Workers Conference in Bangkok in 1907 similar to that which characterises the real revivals throughout church history. As John Eakin said, it was the first most outstanding manifestation of the power of the Holy Spirit in the Siam Mission.

The Siam Outlook described the Conference for Christian Workers of 1924 (Bangkok Station 1925:78-79). The four Siamese churches in Bangkok bore the responsibility of the Conference. Each church delegated four representatives as members of the Conference Executive Committee. There were three Conferences for Christian Workers in Bangkok in 1924, the first taking place in January 1924. That meeting was for preparation and cooperation with the meeting of Dr Biederwolf's team. The second conference was held in June 1924. The theme of the conference was revival. The third conference was held in September 1924. That conference was regarded as one of the very best ever held, of all the twenty-eight that gathered in Bangkok during those twenty years. The programmes consisted of reports from the local churches. They formed two organisations in the meeting. One was the National Missionary Movement (Other evangelistic activities 1926:61) that was formed by the Siamese for their own people. That marked a new era in the mission. The other was the Board of Home Missions which was under the control of the presbytery. The goal of the Board of Home Missions was to evangelise the Siamese by using the Siamese Christians.

There are some important points which should be noted concerning the Conference for Christian Workers.

Firstly, the conference was initiated by Dr George B. McFarland, a missionary of the Siam Mission of the PCUSA, in Phetchaburi. But some time later Thai Christian leaders in Bangkok took the lead in the Conference. Secondly, the Conference for Christian Workers began in 1905. Toktaeng (1984:9) mentioned in his book, *Spread of the teaching in the middle of the 20th century*, that the first Conference for Christian Workers began in 1905. Also *The Siam Outlook* (Bangkok Station 1925:79) made reference to "during the last twenty years" in 1924, which dates back to 1905 as the first year of the Conference. That meeting marked the most extraordinary manifestation of the power of the Holy Spirit for the first time in the Siam Mission

before the Thai church experienced a full-scale revival with John Sung's campaign in 1938 and 1939. Thirdly, the Conference became the seedbed of the revival movement of Dr Biederwolf. He came to Thailand in January 1924. The theme of the second meeting of the Conference for Christian Workers in the year 1924 held in June, was revival. The Conference made an offer to provide playing fields for Dr Biederwolf's campaigns.

5.2.3 Biederwolf Evangelistic Campaigns

The Siam Outlook made reference to the visit of Dr Biederwolf, an evangelist from the United States, to Siam (The Biederwolf meetings 1924:9-10). William Edward Biederwolf (1867-1939), who graduated from Princeton Theological Seminary, was a popular Presbyterian evangelist. He spent several years as an assistant to evangelist J. Wilbur Chapman (1859-1918). He set out on his own evangelistic campaigns in 1906. "His revivals would often include a Civico-Religio-Industrial Parade, which would include community leaders and organisations as well as churches." Premillennialism became a favourite theme in his later years (Trollinger 1999:37). He "promoted a conservative evangelical theology with a strong emphasis on ecumenical endeavors." He blended evangelism and the Social Gospel (:38). William W Sweet (1965:170) asserted that William E Biederwolf was a city evangelist, more or less in the Moody tradition and conservative in his theology.

William E Biederwolf arrived with his team, Mr Homer Rhodeheaver and Miss Saxe, to hold renewal meetings in Bangkok churches in January 1924 (The Biederwolf meetings 1924:9). There were two difficulties. Firstly, the meeting was set in the midst of the king's birthday celebration which continued for two weeks. The Thai displayed interest in the king's birthday so that it was difficult to gather people for the evangelistic meeting. Secondly, the Thai church had never tried an aggressive evangelistic campaign for as long as one week.

Dr Biederwolf preached earnest messages to the Chinese that were translated into Swatow and Cantonese as well as Siamese. Mr Homer Rhodeheaver played the trombone and sang songs that fitted in with the theme of the preaching. Miss Saxe addressed the special meetings for women and held daily Bible classes (The Biederwolf meetings 1924:9-10). Dr Biederwolf came to speak on the playing fields of Bangkok Christian College for many evenings. Toktaeng who was in the

sixth year of High School at the Bangkok Christian College at that time attended the meetings (Toktaeng 1984:36).

After that the churches in Bangkok talked together about revival and arranged a big gathering or conference on this subject. The aim was to get the church to wake up, especially in the matter of evangelism (Swanson 1995:102). As stated above, the subject of the second meeting of the Conference for Christian Workers of the year 1924 which was held in June, was revival, influenced by the **Biederwolf** Evangelistic Campaigns of January 1924.

Dr Biederwolf introduced a new method for the first time in the Thai church history. *The Siam Outlook* (The Biederwolf meetings 1924:9) stated the method and raised the following questions:

In particular, a new method would be presented in requesting converts in a general public meeting to march forward and make a stand before every one. Would this method seem too brusque to the Siamese who have a retiring nature and an innate gentility?

It is generally thought that the Thai are unassuming, and prefer not to express emotion publicly. It is interesting to note how *The Siam Outlook* evaluates the results. "As in the homeland the appeal for immediate decisions, made known by coming to the front, was effective." Thus while it is characteristic of the Thai is to be reserved, with regard to the decision to adopt the Christian faith the Thai can be quite extrovert and self-confident.

William E Biederwolf's ministry was the first mass evangelistic meeting which attempted to use the invitation system in Thai church history. There is, however, no conclusive proof that the missionaries of the APM disapproved of Biederwolf's evangelistic method of calling for decisions in front of the congregation which Charles G Finney and Dwight L Moody used.

5.2.4 Mr Frank Buchman and the House Party Movement

Frank Buchman from the United States, introduced the House Party Movement for the first time in Thailand in November 1925 (Swanson 1995:102). Frank Buchman, an American Lutheran, is the originator of the Oxford Group Movement. William W Sweet (1965:173) stated:

This is a type of revivalism which has appealed especially to large numbers of students in universities and colleges, and to persons in the upper economic and cultural levels. It is a very personal type of approach, and its early converts were won by personal talks with students at Oxford and Cambridge. Its principle emphasis lies upon the guidance that God can and will furnish for every individual; it teaches that God has a plan for every life, but when through personal sin that plan is spoiled "God is always ready with another." To lead the kind of life God has planned for us a person must be willing to surrender "will, time, possessions, family, ambitions." Theologically, Buchman is entirely orthodox; it has been characterized as "orthodoxy galvanized into new life in modern conditions." The movement has had its largest success among the so-called upper classes, where sex and money have been primarily responsible for wrecking God's plan for lives. It is an interesting fact that in America the influence of Buchmanism has been primarily exerted among Episcopalians.

Frank Buchman's evangelistic method was particularly successful among students and the upper class people in America.

Toktaeng (1984:40) said that Mr Frank Buchman contacted the headmaster of Bangkok Christian College, the Rev Marion B Palmer, asking to get acquainted with the pupils in the higher classes of the school, and be able to have meetings with the students. He held a House Party with the aim of confession and guidance at the residence of the headmaster. At first not many students attended these gatherings. He spoke about God's guidance through quiet prayer, coming into God's presence and using silence to hear God's guidance. He conducted a House Party at the Women's Bible School in Bangkok during the first week in November 1925. Miss Margaret C McCord who was the director of the Women's Bible School, described a House Party as a "revival movement". Margaret C McCord (1926:140-141) gave a detailed account of a House Party as follows:

[Mr Buchman] makes an effort to get a group of people together for two and a half days, for stories, the Quiet Hour, and a time of heart searching and self surrender... The need for confession of sin [is] emphasized... we could see that the cleaning out process was having effect. The attitude of the leader is that of a physician trying to get the patient cleaned out. So in those who have confessed, the feeling of loving fellowship prevails over any feeling of embarrassment. The effect of the House Party was cumulative as the days went on.

They held one more House Party in January 1926 with the pastor of the Second Church in Bangkok, the Rev **Charoen Sakoolkan**⁴⁸, as leader. The leader spoke about the importance of soul winning. The meeting touched a large group of Christians. One lady leader of a church confessed her sins with tears and yielded herself to the Holy Spirit. After the meeting the students who attended the House Party experienced change in their daily lives in many ways. The Second Church organised the Fisherman's Club for soul winning as a result (McCord 1926:140-141).

The programmes of the House Party consisted of times of quiet, opening of hearts and minds and confession of sins (Swanson 1995:102). Loren S Hanna (1926:22-24) who was a missionary in Lampang, north Thailand, explained that the House Party had no fixed programme. The people met "in a very informal way...there are indoor and outdoor games, and as much freedom from constraint as may be obtained".

Loren S Hanna invited the pastor of Second Church in Bangkok, the Rev Charoen Sakoolkan, to be the leader of the Bible retreat at Khun **Tahn** Retreat Centre for the Christians of Lampang Station and some members from three other stations. Three out of the eleven days of the retreat were spent at the House Party. This was composed of three different groups, one for young men, one for young women and one for adults. "There were about fifty-five in attendance at the three House Parties" (Hanna 1926:23). Loren S Hanna (:23-24) delineated the meeting in this way:

The leader tells stories of personal evangelism, relates incidences of changed lives, and gives Bible readings and studies; he makes a plea to allow the Holy Spirit to direct the thoughts and words. This leads to many public confessions of wrong doings, to reconciliation with those against whom there has been an ill feeling; to righting of wrongs committed, and to private conferences with the leader or with the pastor, or with others who can help. Through this means a number of our young people who had been living in secret sin or in open shame were touched, and their lives cleaned up. We believe that the experience has been very beneficial not only to those who attended the "House Parties", but also to the Christian community at large.

At first the Rev Charoen Sakoolkan was not fond of stirring people up this way. But as soon as he had experienced it he saw the results: that lives were changed and people were led to feel close to God and close to their friends (Swanson 1995:102). After that the Rev Charoen Sakoolkan arranged House Parties in various places and with various groups. Phetchaburi

⁴⁸ Sometimes his surname is written as Sakoorkan or Sakulkan.

Church arranged two House Parties and invited the Rev Charoen Sakoolkan to lead them. Thereafter the Rev Charoen Sakoolkan and his wife, teacher **Sangad**, started to arrange meetings of this type in churches all over the country. For the most part these were central churches at different mission stations. For instance, in January 1927 the two of them together with students from the Women's Bible School travelled to **Trang** Church in south Thailand. During the following year the Rev Charoen Sakoolkan, his wife and students from the **Women's Bible School** went out visiting many places which were going to hold House Parties. For the most part the results were good. His team arranged this kind of meeting at Phitsanulok Church. Those who attended were so impressed that two people from Phitsanulok followed the Rev Charoen **Sakoolkan's** team to Chiangrai in the north afterwards, in order to take part in another round of meetings (:103).

From 4 to 7 October, 1933 the Rev. Phuang Akaphin led a House Party in Phrae Province. **Thongkham Phantuphong** (1933:27-30) stated that the House Party meeting was similar to the meetings of the Burmese Gospel Team in many ways. He explained that the origin of the House Party meeting goes back to the meeting of the disciples in the upper room in Acts 2. The aim is to wait together to receive the Holy Spirit. The Rev Phuang Akaphin covered the topics of sin, cleansing, the Bible, prayer, worship, being a witness, etc. This preaching was aimed at the heart, to get it to abandon sin and evil and rouse the person to zeal and good conduct. As each topic ended, people would get up and share and confess sin and dedicate themselves. The Rev Phuang Akaphin led the House Party meeting in Phrae Province again from 30 August to 3 September, 1934 (Phantuphong 1934:62). At the last meeting everyone repented and confessed their sins. They all promised before the Lord and the congregation that from then on they would try to be good Christians and help one another to bring about a revival of religion.

There are significant results from the House Party Movement. Here, we can see the phenomenon of true revival in its early stages. It is generally thought that the Thai do not like to push themselves forward nor express their feelings candidly. Toktaeng (1984:43) pointed out that "some felt they had sinned greatly **and confessed** this, some felt uncomfortable because of bad relationships with others or had some weakness that bothered them, and all these things were poured out." When the Holy Spirit confronted their nature they were prepared to submit themselves to God.

This movement helped to bring revival to the churches. Meetings bore different results for the various churches that arranged them. Many members had a longing to develop the church. Some places experienced an increase in the amount of Bible study. Some churches had groups of young people who were strengthened. Nevertheless, the church in different geographical areas began to have common experiences through these activities (Swanson 1995:103).

The House Party movement aroused the expectations and possibility of revival as a group in the local churches, more widely and obviously than through the Biederwolf Evangelistic Campaigns.

5.2.5 The Burmese Gospel Team

A Burmese group, called at that time the Burmese Gospel Team, came to visit Thailand. The first visit was undertaken in 1930. This was composed of nine students of the Rangoon University with Dr Marshall and Mr V W Dyer (The Burmese Gospel Team 1930:456). This team visited Phitsanulok, Bangkok, Chiangmai and Phetchaburi. They had several meetings in Bangkok at the Bangkok Christian College, the Bible Training School, the two Chinese churches, namely the Tie Chieu church and the Cantonese church. They also held meetings at the Second Church and Wattana Wittaya Academy. Afterwards, two members of this team together with the Rev Sook Pongsanoi⁴⁹ had an opportunity to visit Phetchaburi in July 1930 (:456-460). A few weeks later the team went to help at Nakhonpathom (Phetchaburi Station 1931:17). The programmes consisted of singing songs, games, personal testimonies, prayer meetings, simple messages for winning souls. At the end invitations were given to the believers to dedicate their lives to God again and to non-Christians to accept Jesus Christ as their own personal Saviour (The Burmese Gospel Team 1930:456-460).

The attendees at the meetings were impressed that they had experienced "God's presence" (The Burmese Gospel Team 1930:458) and "the power of the Living Christ" (:459). There was a stirring up of people, in that prayer came from deep within the heart. There was a sharing of experiences in life and repentance. Thai Christians were impressed by the faith, the character, the presentation given and the love of the Burmese Gospel Team (Swanson 1995:103-104). They experienced revival. In just two Chinese churches at least fifty people accepted Christ (The Burmese Gospel Team 1930:457). Forty six responded at the Bangkok Christian College (:458)

⁴⁹ Sometimes his surname is written as Pongnoi.

and fifty one responded at Phetchaburi (Phetchaburi Station 1931:17). Afterwards there was a desire to set up such a Gospel Team composed of Thai Christians too. The Lampang Station organised a Gospel Team in September 1930 with eight members from their own congregation (Lampang Station 1932:38).

In 1931 a group from Thailand, consisting of the Rev **Sook Pongsanoi**, Miss Margaret McCord and teacher Singkeo **Suriyakham** went to visit Burma to observe the work of the Gospel Team. On their return they arranged to do this in **Nakhonsithammarat** together with teacher Charoen Sakoolkan. Results were pleasing and exceeded expectations. From there the Thai Gospel Team came and did the same thing in Bangkok. Then in April of the same year there was a getting together of the Thai Team and another team from Burma, the "**Siamo-Burmese Gospel Team.**" This team worked together to win souls, visiting every mission station. There was study and exposition, exchange of experiences, singing of choruses, going out evangelizing. This joint Thai-Burmese team conducted activities for a month. The thing emphasized throughout was the sharing of each other's experiences and praying together until the Thai and the Burmese had a new awakening. A missionary who accompanied them said the aim was to spread Pentecost, so that the church would get the spirit of Pentecost. During that month the Thai-Burmese hardly had any time to rest and sleep, being busy with activities the whole time. Over one hundred people came to believe (Swanson 1995:104; Suriyakham 1932:64-65).

Subsequently, experiences in the style of "Gospel Teams" were popular in the Church of Christ in Thailand. This style was used in many places. The McGilvary Theological Seminary also organised such a team. Lampang followed this pattern as well by setting up a team to pray together, study the Bible together, and go out into the countryside. There was also a team in Nan. Paul H Fuller named the team "the **Siamo-Burmese-American Gospel Team in Siam.**" This was because the team members comprised eight people from Burma, three Americans, four Burmese and one Karen. There were a few American missionaries from the Siam Mission, many Siamese Christians and several Chinese Christians. Average numbers were about thirty. They visited all the mission stations except one (Swanson 1995:104; Fuller 1932:66).

In this movement an individual who was important was the Rev **Boonmark Gitisarn**. He had joined in with the Burmese-Thai team and was one of those who went to Korat with the Thai team after the Burmese team had left. The Rev Boonmark Gitisarn joined the revival movement at this time. After 1931 he was an evangelist in Bangkok and in 1934 he became pastor of the

Second Church, Bangkok. He played a gradually increasing role in bringing revival to the church (Swanson 1995:104)

In 1933 a Gospel Team from Burma came to Thailand once again. They went to Nakhonpathom and worked with the Mon people, going out and visiting them. Later the group divided, some visiting Bangkok churches. Some went to Lampang and Chiangrai and from there returned to Burma. After this the concept of the Gospel Teams spread even more widely among the Thai churches. Almost every mission station set up a team. If the church did not do so, the mission station did. They went out into the countryside, with each team having five to ten members. Generally the various Gospel Teams were formed in the towns and had meetings in town to prepare for going out to the Christians in the countryside, by getting together to study the Bible and pray (Swanson 1995:104).

It would be valuable to examine some important characteristics of this movement. Firstly, the tendency for revival, spread more widely than before among the Thai churches and missionaries. At the same time all the generations and classes of the Thai church cordially received the concept of revival (Suriyakham 1932:65) and vision for more purposeful evangelistic effort (The Burmese Gospel Team 1930:457).

Secondly, the Gospel Team fostered the development of both the pietistic tendency and the invitation system of the revival movement in the Thai church. The Team stressed experiencing God's presence through the "Four Absolute" conditions viz., Absolute Purity, Absolute Honesty, Absolute Sincerity and Absolute Surrender (The Burmese Gospel Team 1930:458). They issued an invitation to anybody who had decided to accept Christ (:457-458).

Thirdly, even though the movement came from abroad and the numerical growth was not startling because of this movement, the spread of the movement was due to Thai Christians, under their leadership and with finance raised in Thailand (Fuller 1932:67). That tendency contributed towards the transformation, and effected significant paradigm shifts, in church leadership from missionaries to Thai church leaders.

Fourthly, the Gospel Team consisted of normal church members, teachers, elders, pastors and missionaries with all parties working together. The Rev Sook Pongsanoi (1939:19) mentioned that the movement helped to cultivate a spirit of cooperation among the Christians. Moreover

there was intimate collaboration between the town churches and the churches in the countryside. The Gospel Teams would set up at the mission centre and go out into the countryside for three to ten days (Swanson 1995:105).

Fifthly, it became a starting point to work together in the true sense with different cultural and ethnic groups, i.e., Burmese, Thai, Americans and Chinese in Thai church. Suriyakham (1932:65) testified that the work with the Burmese Gospel Team "helped many to start new lives and to learn the secret of 'Ko[i]nonia' (fellowship), the art of living together on a higher plane of Christlike spirit." It served as a stepping-stone for a future revival movement in the Thai church in 1938-1939 which removed a barrier among Thai, Chinese and missionaries.

5.2.6 Paul Lyn

The Rev Paul Lyn was a Chinese but had studied in the United States of America for fourteen years. In 1936 he travelled from China to Thailand and spent seven months in Thailand. He did not just stay in Bangkok but travelled about visiting other churches too. He brought to the Thai Christians the style of revival which stirs people up, with the Rev Boonmark Gitisarn travelling as interpreter (Gitisarn 1936:128). The Rev Sook Pongsanoi (1939:19) said that Paul Lyn stressed prayer and reading the Bible. The Rev Boonmark Gitisarn (1936:128) and the Rev Sook Pongsanoi (1939:20) had an unforgettable experience of early morning prayer time with Paul Lyn.

That had a profound influence on the Rev Boonmark Gitisarn. When he worked with Paul Lyn he felt he had had an experience of the Holy Spirit in prayer. He felt great joy in his heart and was in the presence of God. Afterwards he said that very many people had received an experience of this sort through Paul Lyn. People repented, the backsliders came back to God with tears and prayers. Paul Lyn, together with the Rev Boonmark Gitisarn, also travelled to the north. Many people came to them to confess their sins with tears. Afterwards the Rev Boonmark Gitisarn said his best experience was in Chiangrai. During the southern trip they also experienced much blessing by the power of the Holy Spirit. He also thought that the team which went with Paul Lyn had very deep experiences. Paul Lyn worked as a substitute pastor in the Cantonese Chinese Church in Bangkok while the pastor was absent (Gitisarn 1936:128-129).

Paul Lyn was a man of prayer (Lampang 1937:31). Not surprisingly, there was a phenomenon of the real revival and confession of sins, in his ministry in Thailand. Even though he stayed in Thailand for seven months, it may be presumed that his impact was not very big.

5.2.7 Revival Committee of the Church of Christ in Thailand

One outstanding advance made by the 1936 General Council meeting of the CCT was to set up a Revival Committee or "*FuneFu*" Committee in Thai. The General Council asked the Rev Charoen Sakoolkan and the Rev Singkeo Suriyakham of the Committee to go out on visits and arrange meetings to rouse church members to carry out their activities and also to bring spiritual awakening. The two men were entrusted with a mission to the church.

The Rev Sook Pongsanoi was added as a member of the revival committee, and the American Bible Society, with the Rev R O Franklin who was the General Secretary, was responsible for paying the Rev Pongsanoi's expenses. These three travelled together for three to four months, all over the country, visiting churches both in the towns and also the countryside (McFarland 1937:124). "The results were astonishing. Tithing was started or increased in many communities and the spiritual life of many individuals was greatly stimulated" (:125).

Then in 1937 there was a second meeting of the Assembly of the CCT in Chiangmai. One of the important topics at this meeting was the consideration of the results of the work of the revival committee of the Administrative Board. The Assembly showed its satisfaction with these results and accepted the work of the committee (McFarland 1937:127).

The Revival Committee was started officially by the CCT. That means the Thai church accepted the idea of revival that was undertaken by the efforts of outsiders, the evangelists from the United States and China, and by insiders who were in Thailand whether missionaries or Thai Christians. Now all the churches in Thailand were ready to accept the idea of revival. Since they had in some measure already experienced it.

5.3 John Sung's ministry in Thailand between 1938 and 1939

5.3.1 John Sung's invitation

5.3.1.1 Mr Ha Ming Tek and the Rev Sook Pongsanoi

In 1938 Mr Ha Ming Tek, the owner of a rubber plantation in south Thailand, wrote to Dr John Sung to ask him to open revival meetings at Trang Church. At that time the Rev Sook Pongsanoi was the minister of the Trang Church in south Thailand. Mr Ha Ming Tek provided information to the Rev Sook Pongsanoi regarding Dr John Sung in China (Pongsanoi 1968:166). The Rev Sook Pongsanoi shared an interesting personal testimony in *Deeper experiences of famous Christians* (Lawson 1966) as follows:

After being ordained as a minister I moved to work in a church in the South, and was pastor there for seven years. I was very troubled at heart because although I worked hard I produced very little fruit. I was very discouraged and did not know what to do. I went to the church every three days, I prepared sermons and always prayed before preaching. But there were few who repented. I did not see the importance of getting baptised by the Holy Spirit... For this reason I was discouraged at the work I was doing with great diligence. So one day I said to God that I would stop doing His work. "It is no use at all to continue to work so hard and have so little results. I have to work so hard that I am bathed in perspiration. My health is deteriorating. I am almost at the end of my tether but there is no fruit. If the situation is like that, why should I go on working?" (: 138-139).

As soon as evening came I prayed hard. I issued an ultimatum to God saying, "Father, if you don't answer my prayer this night, tomorrow I will pack up my belongings and go back to Bangkok and stop being your servant. I will go and do other work...I'm not going to be a pastor in future...I'm willing to admit defeat." But while I was praying hard that night there arose a storm around the church building. That night I was in the church alone, there was nobody else there, just God and myself. I closed the windows in a hurry to stop the wind rushing in, but when I poked my head out I did not see any storm. The branches of the coconut palms and the other trees around the church were still. I muttered to myself that there must be something wrong with my ears! I had heard the storm blowing, but when I stuck my face outside to see, I saw nothing was happening...what nonsense! I went back and prayed again, but while I was walking inside I heard a voice calling me softly, "My son, don't go back to Bangkok, but stay on here (: 140).

Not many months from now I will show you something will happen, I will show you my work." When I heard this, I knelt down and prayed, "Father, I am not going back to Bangkok, I will do as you have ordered." His voice was a real voice, a voice that came on the wings of the storm that blew hard, but I heard his voice coming from the storm (:141).

After this experience the Rev Sook Pongsanoi worked at the Trang Church continually. A full three months later, at the end of September 1938, Dr John Sung came to Thailand to conduct

revival meetings in different places (Lawson 1966:141). Throughout the next three years, from September 1938 to December 1941, the Trang Church added to the numbers of the church every week. It was a "true revival" indeed (:142).

John Sung's coming to Thailand was God's answer to the Rev Sook Pongsanoi's prayer.

5.3.1.2 Boonmark Gitisarn and the Church of Christ in Thailand

The Church of Christ in Siam (CCS) was established in April 1934. The General Assembly of the CCS had meetings from 7 to 11 April, 1934. The CCS elected the Rev Boonmark Gitisarn as the assistant to the General Secretary. The Second General Assembly of the CCS in 1937 chose him as the General Secretary of the CCS till 1940. He could exercise his rights fully among the churches of the CCS at that time (McFarland 1937:127).

The Rev Boonmark Gitisarn (1979) said that the missionaries of the APM did not allow the CCS to invite Dr John Sung to Thailand. This was because the missionaries had heard bad rumours that Dr John Sung caused division in churches wherever he went (Swanson 1995:108). When the members of the Administrative Board of the CCS voted on Dr John Sung's invitation in 1938, fourteen members attended. Twelve of them opposed having Dr John Sung and one abstained from voting. Only the Rev Gitisarn himself agreed. So he himself invited Dr John Sung in his private capacity. However, Miss Margaret C McCord had encouraged him personally to invite Dr John Sung (Gitisarn 1979).

The Rev Gitisarn invited Dr John Sung to the Chinese churches in Bangkok first. The responses were very good. By the time Dr John Sung had finished his campaigns nobody objected to him because of the remarkable results. After Dr John Sung's first campaigns, the members of the Administrative Board of the CCS met again. The Rev Gitisarn (1979) persuaded the members of the Board that the Thai church was really blessed by Dr John Sung's campaigns. The missionaries themselves saw the good results. The members withdrew the decision that had been made in 1938 and changed it into the CCS welcome to Dr John Sung for the next meetings scheduled for 1939. Thus, Dr John Sung came to Thailand for the second time in May 1939 by official invitation of the CCS. He visited all the main churches of the mission stations of the APM all over Thailand.

5.3.2 John Sung's itinerant ministry throughout Thailand

5.3.2.1 Introduction

It is not necessary to describe **all** the details of John **Sung's** ministry in Thailand here. A brief account of his ministry in Thailand can be found in his Chinese diary, *The diary of his spiritual life of Dr John Song* (Sung 1995b). We will delineate first the general introduction of John **Sung's** visitation of **1938** and **1939** and then the meetings of Nakhonpathom Province in **1938** and Chiangmai Province in **1939**.

The records of the campaigns of **1938** are not entirely accurate because Dr John Sung lost his diary dating from the end of September 1938 to the early part of 1939. The dates and the places that Dr Sung visited cannot be confirmed. But the accounts can be generally trusted as a whole. It is possible to reconstruct the events by receiving help from other source materials in English and Thai. In particular, reports of the campaigns of **1939** can be relied upon. His Chinese diary coincides with the materials available in Thai and English.

John Sung arrived in Thailand for the first time in September **1938** and set off on a **six-week** tour. His second visit was in May **1939** and he toured for two months. These visits resulted in the biggest general spiritual awakening Thailand had yet experienced. John Sung did not come to Thailand by official invitation of the CCT but through the Rev Boonmark Gitisarn who acted as his host in 1938 (Lyll [1954]1965:168). He left Hong Kong on 26 September **1938** and arrived in Thailand by ship (Sung 1995b:267). While there is no information exactly concerning when he arrived in Thailand, we can safely say that he reached Bangkok at the end of September **1938**. He visited three different places namely, Bangkok, Nakhonpathom Province and Trang Province. He also led campaigns in three different places in Bangkok and in one place each in Nakhonpathom Province and in Trang Province. It is evident that his work made less impact on the Thai church than on the Chinese church during the visitation of **1938**.

On 20 May **1939** John Sung arrived at the **Hualampong** railway Station in Bangkok and had his last meeting at Maitrichit Church in Bangkok on 2 August **1939** (Sung 1995b:277). At the time, he spent more time working for the Thai church than the Chinese church (Lyll [1954]1965:168) over a period of two months in eleven different locations in the following order: Chiangmai, leprosy sanatorium in Chiangmai, Lampang, Chiangrai, **Phrae**, Nan, **Phitsanulok**, Phetchaburi, -

Nakhonsithammarat, Trang and Maitricit Church in Bangkok (Sung 1995b:277). The pattern of the meetings was much the same as the previous campaign (Lyll [1954]1965:168). He testified in his diary that "on the whole, 3,000 people were saved, and 1,500 sick ones were prayed for, and 285 evangelistic teams were formed" (Sung 1995b:277).

5.3.2.2 John Sung's ministry in Nakhonpathom in 1938

John Sung went to preach at the Chinese church which uses the Tie Chieu dialect (**Ajharn** 1939:30). His preaching was translated into Thai and Cantonese (Sung 1995b:268). There were both Chinese and Thai members. The meeting was held from Sunday morning, 23 October 1938 to Saturday afternoon, 29 October. There were three meetings per day, each meeting two to three hours long and a total of twenty sessions of preaching; that is, three times from 23 to 28 October and twice on 29 October because that afternoon he had to prepare to travel to Trang. There was a healing service at the last meeting on 29 October (Ajharn 1939:30).

The church members from school children to aged people, including church leaders and missionaries, were hungry to hear John Sung's preaching (Ajharn 1939:31). The Thai and Chinese who came to the meeting averaged 220 people per day (:30). They all thought that his preaching was most excellent. The sermons were about God's love for sinners. He did not criticise anyone in particular. There were many people who wept because of their sin. His goal was to build the church strongly. Thanong Ajharn testified that he had never seen anyone who was filled with the power of the Holy Spirit like John Sung because he was able to preach with a loud voice up to six to seven hours per day (:31-32).

On Thursday 27 October he prayed and laid hands on church members at three different times. The first time was from 09h00 to 09h30 for 180 Chinese church members (Ajharn 1939:30). The second time was from 09h30 to 10h00 for 140 Thai church members. The third time was from 10h00 to 10h30 for 40 church members who were heads of departments (:31). The last service which was in the afternoon of 29 October, was a healing service.

Christians from the surrounding areas came to the meetings. The result of John Sung's ministry was that both Thai and Chinese preaching bands were established. The Thai church had 40 teams and one divided off to the branch of **Nakorn Chum Church, Amphur Baan Pong**, Ratchaburi Province. The Chinese church established 15 teams, two of which joined the Baan Pong group

while one joined **Paedriw** and one **Chonburi**. The preaching bands witnessed to both children and adults (**Ajharn 1939:31**).

John Sung went to the Chinese churches, but besides Chinese, there were Thais and missionaries who attended as well. Although the CCT did not invite him officially in **1938**, the missionaries of APM attended the meetings. The attendees felt and experienced the power of the Holy Spirit from John Sung's passionate preaching which was focused on **God's** love through Jesus Christ. He spent two to three hours on preaching each time. In addition he arranged meetings for **church** members for the laying on of hands. The last meeting was usually a healing **service** wherever he went. He advised and encouraged preaching bands to be formed to evangelise non-believers. He records that "one hundred and sixty three persons [had] received Christ and genuinely repented" (**Sung 1995b:268**). Everyone considered his visit to have had a greater spiritual impact than that of any other similar visit from an outsider, be they foreign or oriental (**Lyll 1965:162**).

5.3.2.3 John Sung's ministry in Chiangmai in 1939

It has been considered that the Chiangmai First Church received the greatest help from John Sung's campaigns throughout Thailand. For its part, this church had prepared the way for the meetings. Announcements were made inviting Christians living in the countryside to come to the church. Financially, the church received more than the amount set as target, and when the meetings were over there was even a little expense money left over. The Executive Committee of the First District was responsible for all the arrangements and there was good communication and co-operation before the meetings. As regards spiritual preparation, there were special services in churches on successive evenings before Dr Sung's arrival, so that hearts might be ready to be awakened in the Spirit (**Singhanetra 1939b:25**).

John Sung arrived in Chiangmai on 25 May **1939** with his interpreter, the Rev Boonmark Gitisarn by train from Bangkok (**Sung 1995b:275**). He led meetings from 28 May to 2 June **1939**. Dr Jinda Singhanetra asserted that the method of John Sung's preaching was strange and unique but that he had never heard anyone preach so well before. He began the meetings by practicing choruses, and hymns continued to be sung during the service. He stirred up his listeners continually and taught them to pray loudly all at the same time. His teaching put much emphasis on the Holy Spirit. The most important thing was that he was well-versed in the Bible and knew how to quote passages to examine and to preach from in thorough detail (**Singhanetra 1939b:25**).

Several missionaries who were experts on the Bible agreed that they had never met such a good exponent of the Scriptures in their lives.

“[T]he meetings were well attended and more than one thousand made confession of sins” (Editorial 1939:113). We may say that John Sung's meetings in Chiangmai brought about the first large-scale group confession of sins and manifestation of the power of the Holy Spirit among all the congregations in Thai church history from the arrival in Thailand of the first Protestant missionaries in 1828 until 1939, i.e., in over a century. The Rev Sook Pongsanoi gave evidence that “[t]here were 1,057 who went to the altar to confess their sins and to ask for forgiveness from the Lord. At least one thousand people attended each session. On the last day the whole congregation wept and confessed their sins in the meeting” (Excerpts from letters 1939:114).

At least three results of the meetings in Chiangmai are discernible. Firstly, sixty-two gospel bands were formed to witness Christ at least once a week (Singhanetra 1939b:26; Excerpts from letters 1939:114). Indeed, the spirit of evangelism was great in Chiangmai (Excerpts from letters 1939:114). At the end of the last meeting John Sung called people who would like to share the gospel with others and about three-hundred responded. The great majority of these volunteer gospel bands consisted of young people and they became a great source of strength to the church and society in general (Singhanetra 1939b:26). Fifty young men and women dedicated their lives in service of the Lord (Sung 1995b:275).

Secondly, there was an explosion of enthusiasm to study and to know the Word of God. “In the villages there are worship services with everyone bringing a Bible and studying it constantly” (Singhanetra 1939b:27). And thirdly, the Christians experienced a true revival. The Rev Sook Pongsanoi reported, “[t]he whole church is on fire now... Lives have been changed, restorations and confessions have been made. The living power of the Lord can be seen through the action and the changing of the people's lives” (Excerpts from letters 1939:114). The backsliders came back and the weak became strong again. Churches were full to overflowing with worshippers (Singhanetra 1939b:27).

Briefly then, Chiangmai Province became a Christian centre after Daniel McGilvary arrived in Chiangmai in 1867. In one sense the Laos Christian Convention which was first held in

Chiangmai in 1903 became the starting point of the revival movement in Thailand. And the 1939 revival movement in Chiangmai became the catalyst for future revival in the Thai church.

5.3.3 The phenomena, characteristics and emphases of John Sung's campaigns

This section is divided into three parts: the phenomena of John Sung's meetings; the characteristics of John Sung's preaching; the emphasis of John Sung's preaching.

The present writer will delineate these three parts validating his conclusions from three sources: the corroborative facts from the witnesses that he interviewed; the cassette tapes made by the witnesses of the attendees of John Sung's meetings, which can be found in the Archives of the Payap University, Thailand; the books written by some members of the congregations of John Sung's campaigns at that time.

The two most famous Thai church leaders who were companions and interpreters of Dr John Sung were the Rev Boonmark Gitisarn and the Rev Sook Pongsanoi. Their witnesses as protagonists of the meetings provide the clearest evidence.

5.3.3.1 The phenomena of John Sung's meetings

Firstly, it was almost the norm that most of the attendees of John Sung's meetings repented of their sins. There was much crying at the meetings and there was also evidence of repentance in the daily lives of those present at the meetings.

The Rev Pongsanoi was impressed by the picture of people confessing their sins. Some cried with sorrow while walking out through the crowd to the front of the pulpit. It was a time of real repentance (Pongsanoi 1968:171). "There were people weeping loudly when they listened to the forgiveness of sins" (Lawson 1966:126).

The Rev Gitisarn (1979) also testified:

I have never seen anyone who prayed like him with people all crying all over the meeting. But in Dr Sung's case, no matter where the meetings had been, the day he was leaving, as soon as he prayed the whole church was full of people crying. Everyone was in tears, sorry that he was leaving, wanting him to stay, or missing him. All my life I have never seen anything like that.

The writer interviewed **Khamdi Jaisuk** (2000) who was a witness of John Sung's meetings of Nan Province on 23 -29 June 1939. She stated that at the Nan Church, the response to listening to Dr Sung's preaching caused one to repent. When Dr Sung preached, many were in tears, deeply conscious of their sins. Everyone cried and confessed their sins and everyone's heart was changed.

Pongsanoi (1939:21) said:

At present great changes and a movement have taken place at the Trang Church. People have really repented, from children to white-haired older folks. Those with second wives have arranged to separate from them quietly and explained to them the reason for this. While they do not yet have a new husband the former husband will support them including their children but are not willing be together as husbands and wives in future. Thieves have restored stolen goods to their owners and to the church. Offerings have doubled.

We can see the evidence of the substantial changes in the daily lives of those who attended any of John Sung's meetings. Pongsanoi (1939:22) asserted that “[a]ll this is the fruit of the Holy Spirit who stirs people to repentance and to be aware of themselves.”

The second phenomenal change was that people became keen on attending services not only during John Sung's campaigns but also at the local church level after John Sung's meetings had ended. Backsliders were restored and in addition, a number of Buddhists were converted. Therefore the result was considerable numerical growth at the local church level.

Bunmi Rungrueangwong (1979) asserted, "No matter which church it was that Dr John Sung was going to preach in, people would follow so the church was full every time. Whether it was in Chiangmai, Phitsanulok, Phetchaburi, people would follow to hear him." People came to worship services filling the churches (Pongsanoi 1968:171). Pongsanoi (1939) testified regarding the numerical growth of the Trang Church and the return of the backsliders:

On November 13th 1938, sixteen men and five women were baptised. Nineteen people who are children and grandchildren of Christians have asked to become church members. Some who have been lost sheep away from the fold ten years have come and confessed their sins in church. Two were received back into the church the same day. Altogether forty-two were received into membership that day (:21).

Since Dr Sung left, people have crowded into the church. The attendance at the mid-week prayer meeting is five to ten times as large. On Sunday morning we have had to move the service forward. Before, we used to meet from 11.00 to 12.00. Now an hour's preaching and worship is not enough. Because many want to speak and give testimonies...We have to take two hours and then people are not ready to stop. Before people said an hour's worship was very long but now over two hours is too short. In the afternoon we have meetings in homes. People fill the houses till there is no place left to sit (:21-22).

Even though only a few Buddhists who had come to believe during the meetings, this was a real revival among Thai Christians (Nishimoto 1996:46). Allen Bassett (1939:168) shared his testimony:

Where we once counted our converts by ones and twos we are now counting them by tens and fifties and in some places even by hundreds. One church, whose pastor has seen a vision, has received 125 new members and baptised over forty new converts in the last two months. More than six hundred men and women have pledged themselves to become teachers and preachers of the Word."

The Thai church experienced real church growth in quantity and quality. John Sung recorded in his Chinese diary (1995b:277) that as many as 3,000 people were saved in Thailand during the campaigns of 1939 only.

Thirdly, a phenomenal number of those who attended the meetings dedicated themselves to God. In his Chinese diary, John Sung (1995b:275-277) counted the numbers of people who devoted themselves in 1939 to God for full-time Christian ministry and for sharing the gospel in many places. "Fifty dedicated their lives to serve the Lord" in Chiangmai. "Forty gave their lives to preach" in Phitsanulok. "Thirty three people dedicated their lives" in Phetchaburi. "Forty two dedicated their lives for full-time ministry" in Bangkok.

Finally, the attendees of the meetings had an overwhelming thirst to study God's Word. Pongsanoi affirmed that Dr Sung was 'a man with iron bones', who had a superb knowledge of the Bible which would be difficult to match (Pongsanoi 1968:127). Dr Jinda Singhanetra (1939b:25), who was a renowned Thai Christian medical doctor and one of the advocates of John Sung's campaigns, said in *The Church News* "The most important thing was that this man was an expert in the Bible and knew how to quote passages to examine and to preach from in thorough detail for us to drink in." Allen Bassett (1939:169) said that "[a]t the last meeting without

missionary initiative it was voted to establish a Bible school." Even if the Bible school issue became a big problem within the CCT afterwards it is clear that John **Sung's** excellent exposition of the Bible made those who listened to his preaching desire to study God's Word more.

5.3.3.2 The characteristics of John Sung's preaching

The general tendency of John Sung's homiletics are mentioned in Chapter 4.4.10. Here it is intended to delineate his characteristics of preaching in Thailand only.

Dr John Sung preached differently from the Presbyterian missionaries from the PCUSA at that time. The missionaries had their own style of preaching. Generally speaking they were polite, used elevated language and did not use strong gestures much. The preaching style in John **Sung's** case was totally different from that of the missionaries. John Sung was demonstrative and energetic showing a great passion for the topic which he was preaching (Kho 1999).

John Sung's theology was, furthermore, not the same as the Pentecostal theology of that time. His theology was conservative and not very different from that of the missionaries, as is mentioned in Chapter four. But unlike missionaries who dressed in formal suits when they preached, John Sung wore simple clothes for his preaching. Prathum **Darum** (2000) said that "Dr Sung was dressed in white and I remember he had a wooden stick to beat out the rhythm of the music. I remember he cut his hair rather short." His different style of preaching, his unique character and attire earned the missionaries' resentment.

John Sung was a very strict person. The Rev Pongsanoi reflected on one anecdotal incident that had happened when he travelled with Dr Sung to interpret his sermons. One evening he was playing badminton for exercise. When John Sung saw him, he said, "Are you a child or what? You need to keep your time for God." Thereafter John Sung forbade him to play badminton. He was quickly roused to anger but was never angry for long. Five minutes later he had forgotten the whole thing (Pongsanoi 1968:168). In Rev **Pongsanoi's** words,

He easily got angry. When doing anything it had to be as he wished. Whatever he did he really set about it, but he was not angry for long, five minutes later he had forgotten the thing... If anyone smoked a cigarette, he would scold loudly saying, 'This is not a place of entertainment.' If the person took no notice and did not put out the cigarette, he would stop preaching. He would wait

until that person put out his cigarette. Or sometimes he would chase a person out who was not listening properly. He was not concerned about whether people approved of him or not, as long as he had the approval of God (:168-169).

When preaching he really threw himself into his gestures. While he was preaching, none could nod off, for he jumped about noisily. Some people said that Dr Sung was mad, and dishonored God because he used too many gestures in his sermons (Pongsanoi 1968:169). As he had a very loud voice, one could hear him from quite far off (:171). He used strange poses in order to "win souls" in the audience. Some people felt embarrassed and did not like it (Swanson 1995:106). Dr Jinda Singhanetra testified thus (1939b:25-26):

Dr Sung's method of preaching was strange to us, a method no one had used before. He began by practising choruses and there was frequent singing of songs during the preaching. He taught us to pray out loudly all at the same time... He stirred up his listeners the whole time. The writer of this can say with full conviction that he has never heard anyone preach so well, and knows that some Christian leaders well versed in Scripture testify to the same thing. At the end there was special prayer and there was always an appeal to dedicate oneself.

The Rev Samuel Kho (1999) who had heard John Sung preach in 1938, at the Maitrichit Church in Bangkok when he was nineteen years old, stated that John Sung preached creatively and in a visual way. Bunmi Rungrueangwong (1979) said:

If he was preaching on Nicodemus, who was an old man, he would take a square cloth and put it over his head so as to look like someone with gray hair and make out he was an old man, with actions to suit... When he came to preach revival he often pointed at people, pointed at them in the face, pointed all the time.

He had them bow their heads and close their eyes and then called on those wanting to confess their sins to God to lift their hands up, and walk up to stand in front of the pulpit (Pongsanoi 1968:171).

Pongsanoi (1939:20-21) affirmed, "I can say that God was with this man the whole time. I came to understand the cross more clearly than before, saw the power of the Holy Spirit more clearly than before." He preached very fervently indeed (Darum 2000). The Rev Samuel Kho (1999) said that he was wearing a white shirt and it was soaked; all of him was soaked, and perspiration just ran off him. Darum (2000) again testified that there was singing and teaching alternately.

That which went deepest was prayer; he prayed using loud voices, praying and walking around, walking around making contact with each one, each and every one.

5.3.3.3 The emphases of John Sung's ministry

It appears that John Sung stressed various doctrinal points in his ministry in different countries. We are here concerned with his emphasis in Thailand only. This can be summarized in **five** main themes, namely salvation through Jesus Christ, repentance, evangelism, **sanctification** and the Bible.

Firstly, John Sung stressed the theme of salvation through Jesus Christ alone.

The Rev Pongsanoi stated that Jesus Christ dying on the cross to redeem sinners was the greatest story in his teaching (Lawson 1966:128-129). Once John Sung went to hear Dr Nagawa who came from Shanghai. He did not accept him, because he did not feel his ministry was Christ centred. Dr John Sung held firmly to one thing **only**—Jesus Christ together with salvation from sin (Toktaeng 1984:110).

Secondly, John Sung laid stress on the need for repentance.

The Rev Sook Pongsanoi mentioned, "Dr Sung, like John the Baptist, taught them to repent" (Lawson 1966:127). He emphasized confession of sin, asking for forgiveness (Swanson 1995:106). In his preaching he emphasized repentance (Pongsanoi 1999). Boonmark Gitisarn (1979) said:

They confessed their sins because Dr Sung had to have this time of confession whenever he finished preaching, and all those who wanted to confess sins went and put up their hands to say what they had done, and Dr Sung would mention this sin or that, such as adultery, drinking, smoking, things like that, and then people would gradually raise their hands to confess.

He helped people to treat their sins thoroughly one by one.

Thirdly, John Sung emphasized evangelism wherever he went. Pongsanoi (1968:128) recalled John Sung's preaching that we must "witness to someone at least once a week telling them how Jesus has changed our life." Mien Pongsanoi, the younger brother of the Rev Sook Pongsanoi, testified that "before this we just worked in the church only and did not go outside, but Dr Sung

came to teach us to reach out, to open ourselves up and go out and evangelise" (Pongsanoi 1999). All the mission stations where he preached organised witnessing bands. John Sung (1995b:277) himself recorded in his diary that the Thai church organised 285 evangelistic teams in 1939. He strongly disagreed with evangelism through social action those who held to liberal theology (Toktaeng 1984:110).

Fourthly, he laid stress on sanctification.

Pongsanoi reflected on John Sung's sermon that "we must withdraw far away from sin and become intimate with God through prayer and reading the Bible" (Lawson 1966:128). Bunmi Rungrueangwong (1979) remembered John Sung's preaching, Jesus said your life is the temple of God, so why do you have to put addictive drugs into your body? The body is the temple of God, the place where God dwells. Putting addictive drugs in the body is making the temple of God unclean, is spoiling it.

Fifthly, John Sung emphasized the Bible.

He took no interest in himself or anyone at all as much as he did in God and the Bible (Lawson 1966:128). Nishimoto (1996:45) said that "his preaching was in line with the Bible in every respect, to the extent that we did not agree with some of it."

Chalit Prichakul (1985) admitted that "there was laying on of hands for healing for the first time. Some people cried and various evil spirits came out of people; some sick people were healed." But Robert Nishimoto (1996:45) asserted that John Sung followed the Bible regarding healing. It was not new or strange, but he tried to avoid laying on of hands because he did not want to give rise to misunderstanding on account of the psychological effects of this action.

It is no exaggeration to say that John Sung's meetings constituted a real revival when we examine the phenomenon, characteristics and emphasis of the campaigns. As Swanson (1995:106) evaluated, "Some people felt embarrassed and did not like it, but it looks as if those who felt like this were in the minority. Our Christian Thai brethren for the most part felt there was good sense in his teaching of the Word of God." The majority of the Thai Christians welcomed John Sung's campaigns, but minorities of the attendees of his meetings were dissatisfied with his preaching and evangelistic method. As far as the American missionaries were concerned, it seems as if they were less impressed with Dr Sung's campaigns than the Thai Christians. This was probably because they were too accustomed to the American Presbyterian

style. The preaching style and unique character of John Sung were greater obstacles than his theology, for the American Presbyterian missionaries.

5.3.4 The receptivity to the gospel of the Chinese Thai and the Thai

"Chinese traders were already established in the markets and ports of the Gulf of Siam when the Thai reached the **Jaophraya** Delta and the Malay Peninsula in the thirteenth century" (Skinner 1957:1). Many Chinese had immigrated to Thailand over a long period of time. G William Skinner (: 173) estimated in 1957 that "at least half of the China-born Chinese living in Thailand today first immigrated during the 1918-1931 period." While the Thai government estimated the populations of Thailand as 14,114,709 in 1937 (Seigle, J Y 1939:54-55), reliable statistics of the total number of ethnic Chinese in Thailand are not available. Nevertheless the Chinese government placed official estimates of the total number of Chinese in Thailand at 1,500,000, in 1934 (Skinner 1957:181). Even though it is not easy to estimate the percentage of the Chinese in Thailand during John Sung's visitation in 1938-1939, it is likely that the Chinese in Thailand at that time totalled more or less ten percent.

"A survey of the history of the various Protestant missions in Thailand clearly indicates that the Chinese people have responded to the Gospel more rapidly than the Thai people" (Blanford 1975:xii). There are many examples to support the fact. In 1828 the first two Protestant missionaries, Carl A F Gutzlaff and Jacob Tomlin, arrived in Thailand. Within three years, Carl A F Gutzlaff had baptised a Chinese convert, named Boon Tee (Wells 1958:5-7). John Taylor Jones from the American Baptist found the Chinese more responsive to the gospel than the Thai and baptised four Chinese in 1833. William Dean organised the first Protestant church in Thailand in 1837 with Chinese and Westerners (Blanford 1975:33). American Presbyterian work in Thailand began in 1840 and it took nineteen years before they saw the first ethnic Thai convert (Wells 1958:27). The Presbyterian mission had more success in their ministry among Chinese than among Thai people in its beginning stages even though their work was done in the Thai language (Blanford 1975:39).

We encounter difficulties when we try to figure out the number of Chinese Christians out of 8,413 total communicant members of the CCT in 1938. Therefore it may be helpful to compare the general responses of the Chinese and Thai during John Sung's campaigns in Thailand in 1938-1939.

There is enough evidence to demonstrate that John Sung preached to the Chinese more than to the Thai in 1938. Conversely, his mission in 1939 did more for the Thai. Alex Smith interviewed Dr Jinda Singhanetra in 1977 and he testified that "during Sung's 1939 visit the Thai church received more blessing than the Chinese church, but many of those revived were actually from Chinese or Siamo-Chinese backgrounds" (Smith 1982:195). *The International Review of Missions* reported the situation of the Chinese churches in Thailand in 1939. "As a result of the work of the Chinese evangelist, John Sung, a new spirit is seen in the Chinese churches" (South-East Asia 1940:22). In 1940, one year after John Sung's campaigns, half of the Christian community in Bangkok was Chinese (South-East Asia 1941:24). When we take into consideration the fact that the majority of the population of Bangkok were Thai at that time, we can easily conclude that the ratio of Christians to non-Christians was higher among the Chinese than among the Thai considering the population ratio of the two groups.

Samuel Kim (1980:56) gave an interesting observation regarding the reason why the Chinese responded more than the Thai to John Sung's campaigns. For the Thai, who do not show their feelings and tend to be quiet, John Sung's preaching must be reckoned to have been too heavy and striking. His teaching and testimony were too powerful for the Thai. It seems quite possible that Samuel Kim's opinion is correct. Mien Pongsanoi (1999) also acknowledged that the Chinese like to display their feelings more openly than the Thai. It is quite likely that the Thai characteristic traits *Jai yen* (Komin 1991:144), —calm, easy-going, not easily excited— influenced the responses of the Thai toward John Sung's preaching.

We can also conclude with some precaution that the Thai nationalism during Phibun Songkram's government which discriminated against Chinese (Skinner 1957:261-278) had a positive influence on the receptivity of the gospel for the Chinese and Thai-Chinese as we have seen in Chapter 3.5. Possibly various social pressures since December 1938 promoted and helped them to be more receptive to Christ.

It can be observed that Chinese and Thai-Chinese churches have better growth on a long-term basis. Lifelong commitment to Christian service marks many of Sung's converts in leadership in Chinese churches throughout Thailand.

The visitors from outside of Thailand adopted a mass evangelistic invitation system used by, among others, Charles Finney, Dwight L Moody and Billy Graham; but there is no theological debate or argument from the missionaries of the APM about that. When Dr John Sung used the same evangelistic methods which they had employed, the missionaries of the APM rejected his way of doing so, even though several missionaries agreed with and supported him. We will discuss this problem further in the following chapter as well as providing an evaluation of John Sung's campaigns in Thailand.

Chapter 6. An analysis and evaluation of John Sung's ministry

6.1 Introduction

This chapter aims to analyse and critically evaluate John Sung's ministry in Thailand. The reason for this is to understand clearly the impact made by John Sung's campaigns.

Although some studies have been made on these campaigns in Thailand, very few attempts have been made to research them holistically. Robert Nishimoto (1996:43), an authority on the history of the church in Thailand is of the opinion that John Sung had a great and lasting influence on the Thai and Chinese churches when he visited that country in 1938-1939. There was scant praise from the public, however, in spite of significant accomplishments during and following his ministry in Thailand.

At the outset we will consider different opinions with reference to the campaigns. Following this, the results of the meetings will be explained together with some issues which gave rise to serious trouble within the CCT. Then an ecclesiological evaluation and an historical interpretation of the events will be elucidated. Finally we will observe John Sung's theology of revival and the important lessons of the campaigns as they relate to both the Thai church and the missionaries.

6.2 An analysis and evaluation of John Sung's ministry in Thailand

6.2.1 Differences of opinion between protagonists and antagonists of John Sung's campaigns

There is no doubt that Dr John Sung was a man whom many loved and some people hated. He was so single-minded in his mission that even though he was criticised severely by some influential leaders both national and missionary, he took no notice of these criticism since he was convinced that he was called of God (Nishimoto 1996:43).

6.2.1.1 The opinion of the protagonists

History affirms that most Thai Christians and several Presbyterian missionaries were zealous supporters of John Sung's campaigns. The best known protagonists of his campaigns were the two principal interpreters of the meetings, namely the Rev Boonmark Gitisarn and the Rev Sook

Pongsanoi. The Rev Boonmark Gitisarn affirmed, both in writing and verbally that the power of the Holy Spirit was manifested and there was evidence of true conviction of sin in all of the meetings. He further testified that he had never seen any person preach so convincingly or powerfully who could be compared with John Sung. He stated that he had attended many evangelistic campaigns led by famous preachers from abroad, but that nobody could surpass John Sung in terms of lasting results (Gitisarn 1979).

The Rev Sook Pongsanoi was the pastor at the Trang Church when John Sung visited Thailand. He invited John Sung to his church in 1938 and 1939. He confirmed that many received blessing and revival, or were converted to a new life which they had never envisaged before (Pongsanoi 1939:18). At that time great changes took place at the Trang Church. People, from children to white-haired older folks, really repented. Offerings doubled. Many baptisms followed his visit to the church. On 13 November 1939, sixteen men and five women were baptised and nineteen people asked to become church members. Some backsliders repented and came back into the church on the same day. Altogether forty-two people were received into membership that day. This impact was not just during the brief visit. Even after John Sung had left, people continued to crowd into the church. According to Sook Pongsanoi (1939:20-22), God was evidently with John Sung. He, further, (Pongsanoi 1938a) said, "Trang Church is on fire and the Holy Spirit is a real thing which can be touched and felt." Pongsanoi (1938b) also referred to Paul Eakin, who stated "this is the work of the Holy Spirit not man's work."

The Rev Loren S Hanna (1939b), the missionary of the APM in Lampang, adopted the most positive attitude toward John Sung's campaigns among the APM missionaries. He sent a letter to his friends after the meetings in Lampang which were held from 3 June to 8 June 1939 which he evaluated as follows. John Sung is "true to Scriptures in every way that I could discern...302 people made confession of sin... Many of these were people that we had sought to bring back for many years." He continually made reference to the fact that they were thrilled to see the backsliders come back and join the church. He indicated that he was deeply impressed by John Sung's prayer life and his preaching in the power of the Holy Spirit.

Another missionary, Graham Fuller (1939) stated that John Sung's meeting in Bangkok was one of the greatest experiences of his missionary life. And Samuel Kim also reported that the revival

which was brought about through **Sung's** campaigns was "the most vital cause for the rapid church growth from 1940-1950" (Kim 1980:59).

Missiologist Alex Smith (1982:197) emphasized, likewise, that "[t]he revived church, spiritual leaders, and the strategy of witness teams all came out of the revival." An important source of information from that period, *The Siam Outlook*, which was the official quarterly magazine of the APM, October 1939 issue, made it quite clear that not a few Presbyterian missionaries themselves believed that the Thai church had experienced a genuine spiritual revival through John Sung's ministry. Together with this evidence is the fact that undoubtedly, the majority of the Thai Christians at that time agreed with one accord that they had had unforgettable experiences of true revival. The writer has personally interviewed a number of Thai Christian's who had been present at the campaigns, namely **Khamdi Caisuk**, **Mien Pongsanoi**, **Pratum Darunnart**, **Sican Kitiwong**, **Samuel Kho**, and **Sutharat Citchang**. They all unanimously witnessed the campaigns as a genuine revival movement which Thailand had never experienced either before or after John Sung's meetings.

6.2.1.2 The opinion of the antagonists

We find the most severe criticism of John **Sung's** ministry in Thailand in the document; called "Mr. Hanna's case." This document reported (Eakin [s a]:1):

[John Sung] did stir up the enthusiasm of the nationals and won over some missionaries to a rather emotional type of religion. Interest in the Bible was stimulated and much good was done. However, he was extremely divisive. All who did not interpret the Bible as he did were "heretics and come from the devil." His followers continued this slogan with the result that ever since then the Church and Mission force have been split wide open. This condition is still plaguing the Church today.

The document concluded that John Sung had conducted highly emotional revival meetings and that he was an untrustworthy divisive person who had induced the church and the APM to split.

It is not easy to understand the opinion of the antagonists of the campaigns because there is so little first hand material. But it is possible to theorise from John Sung's whole ministry in China and abroad some important reasons why some missionaries from the APM and few Thai Christians who closely worked with the missionaries were opposed to his ministry. There are

five possible reasons which may have been the cause for the antagonists to have such negative attitudes towards John Sung's ministry.

Firstly, there was rampant rumour amongst missionaries regarding John Sung being deliberately sectarian.

Before John Sung came to Thailand, some APM missionaries mistakenly understood that he had promoted division within the churches in China. They wrongly concluded that if he came to Thailand he would instigate a split of the church. Dr Jinda Singhanetra (1979) testified that the reason why the Presbyterian missionaries opposed John Sung's coming to Thailand was that wherever John Sung went **they** claimed that dissension followed.

Sources indicate that this was clearly a rumor, which John Sung's antagonists started. John Sung had not in any way been sectarian in China as records prove. On the contrary, he had always endeavored to preserve the unity of the church. There was only one "case of a separate church group arising out of the work of Dr Sung." In that case it had not been his intention, but some Christians in Tientsin area decided to split from their churches regardless of John Sung's wishes. The Christians in Tientsin invited John Sung to visit them. All the Tientsin churches refused to use their church building for special meetings. Some of the prominent figures in the churches even opposed his work in every possible way. So the churches made a decision to use a large ancestral hall for the meetings. Afterwards over three hundred Christians left the churches to build a new hall for preserving liberty of worship. John Sung "warned them against a sectarian spirit", but they did not listen to his advice and completed the new meeting place a year later. That was not John Sung's intention in the first place (Lyll [1954]1965:125-126). As we have seen from John Sung's ecclesiology in Chapter four, we cannot presume that John Sung incited Thai Christians to separate from the Presbyterian Churches.

Even though some Thai church leaders separated from the CCT with the Rev Boonmark Gitisarn after the Second World War, we can conclude that it was not John Sung's original wish but the Thai church leader's attitude, especially the Rev Boonmark Gitisarn himself. This point will be examined later in Chapter 6.2.4 where an ecclesiological evaluation of John Sung's ministry will be undertaken.

A second focus of criticism concerns the critical attitude toward undedicated Christians. John Sung denied himself and followed Christ wholeheartedly (Lyall [1954]1965:viii). He threw away, into the sea, all his medals and diplomas except a doctorate, thereby repudiating on academic career and the symbols of his brilliance before he arrived in China (Tow 1985:86). John Sung had a strong will and a hot temper and could even be rude (Lyall [1954]1965:vii). Like Jesus he detested hypocrisy. "He played the part of John the Baptist in his fierce rebukes, and was particularly outspoken in his condemnation of ministers who were preaching another gospel or contradicting the truth by their lives" (Lyall [1954]1965:x) He made a mockery of nominal Christians and lazy pastors in the public. He could not tolerate all the people who had not or would not commit their lives to God.

Samuel Kim (1980:59) met many witnesses of John Sung's campaigns and he stated adamantly:

Wherever John Sung went, there were strong opposers among the missionaries... Some missionaries complained that Dr Sung criticised missionaries who sometimes were insulted by certain manners. Some liberally oriented missionaries did not like his Bible-centered message.

Samuel Kim's explanation is correct. **Bunmi Rungrueangwong (1979)** attested that missionaries at that time understood that John Sung was a confrontational preacher who refused to use tender man-pleasing words. He criticised missionaries, accusing them of not putting their backs **into** the work. Also he blamed missionaries who themselves were not born again and who did not teach others how to be saved from sin. He criticised them severely to the extent, he said that they are like pig teachers who are getting fatter and fatter, eating, sleeping, and only producing children. He rebuked Thai church leaders too. Because of this reason the ordinary people liked to hear him preach. There is enough evidence that John Sung's denouncement of missionaries and church leaders became the seed of the division in the church. His attacks "aroused the very natural antagonism of those who were unwilling to accept his strictures" (Lyall [1954] 1965:56).

Thirdly, John Sung's creative and different style of preaching.

In his book, *John Sung*, Leslie T Lyall ([1954]1965:157) testifies that John Sung "is a man who puts himself and Christianity into the news by his unorthodox ways, which always annoy the orthodox." John Sung used English when he preached. Some missionaries did not like his English spoken with a Chinese accent (Pongsanoi 1999; Singhanetra 1979). His preaching style

was creative and so different from the traditional style as we have seen in Chapter four. He was not a man of courtly manners and well-tailored clothes (Lyall [1954]1965:191). He acted humorously and grotesquely in his preaching (Lyall [1954]1965:118). When John Sung preached "he would walk down the isles and point his finger in the face of someone in the audience, then rush back to the front of the church and perhaps stand on the communion rail to finish his sermon!" (Lyall [1954]1965:49). It follows from what has been said thus far that the Presbyterian missionaries would not have found it easy to accept his preaching style.

Fourthly, John Sung's independent spirit.

A rebel as a boy, he remained an individualist all his life (Lyall [1954] 1965:vii). He rebuked Chinese churches that relied on finance from overseas. He said that the reason why Chinese churches asked for financial help from outside was lack of faith (Sung [s a], 2:12). When John Sung heard that the missionaries threatened to cut financial support to the church if they did not cancel their invitation to the Bethel Band in 1931, he wrote in his journal: "[b]eloved fellow workers and fellow Christians! Why do you still depend on the financial support of foreigners? You **should** look to the Lord of all things and realise that the time has come for the church to be self-propagating, self-governing and **self-supporting**—truly independent!" (Lyall [1954] 1965:77). When John Sung seceded from the Bethel Band in 1933, "he could no longer tolerate being... under the direction of a foreigner" (Lyall [1954]1965:120). John Sung would have been unhappy if he knew that the CCT, which became independent in April 1934, was still under complete guardianship of the missionaries of the APM with regard to finance and administration (Pongudom 1984:75).

Fifthly, there were, possibly, theological discrepancies.

"His fiercest denunciations were for those who had departed from loyalty to **God's Word**" (Lyall [1954]1965:192). In other words, he denounced all unfaithfulness to the Word of God. (:102-103). He did not like some of the modernistic missionaries who had liberal tendencies (Kim 1980:59). Some missionaries interpreted John Sung's campaigns incorrectly as a hyped up emotional type of revival (Gitisarn 1979). In fact, he did not encourage emotionalism in his meetings. Many of the protagonists of John Sung's campaigns generally believe that the reason why the antagonists misunderstood him was that God has been working so powerfully through his preaching by the power of the Holy Spirit, that the conviction of sin and the weeping that

followed were common phenomena at his meetings. The Rev Boonmark Gitisarn (1979) referred to his walking about and laying hands on people to receive the Holy Spirit. Carl Elder (1940b) mentioned his anointing the sick with oil. Wherever John Sung led the last service, the meeting took the form of a healing service and he prayed for the sick. It was reported that "the blind were made to see, the lame walked, the dumb recovered their speech and many kinds of sickness were healed" (Lyll [1954]1965:168). It is highly probable that this style and approach which was so different from the Presbyterian missionaries' normal methodology was viewed as theologically unsound by his antagonists.

6.2.2 Results of John Sung's campaigns

6.2.2.1 Positive results of John Sung's campaigns

Firstly, the Thai church had experienced a real spiritual revival and renewal.

The revival under John Sung was "the renewal of Christians, the restoration of backsliding members, and the conversion of those who claimed the name of Christ but who lacked a personal 'born again' experience with Him" (Swanson 1982:196). There was a real change in the lives of the Christians, the same results as after other revival phenomena in church history (Nishimoto 1996:45; Gitisarn 1979; Singhanetra 1939b:27).

Secondly, John Sung was instrumental to the building up of the confidence of both the Thai church in general and the leaders of the church in strength and faith.

Swanson (1995:107) was convinced of the fact that John Sung's campaigns were very important because it was the Thai who invited Dr Sung to the churches. Even though there were some missionaries who supported the campaigns, nevertheless the leading party was that of the Thai Christians. Those who were excited were the Thai. That Dr Sung had a great influence on the young people is indisputable. The strong fire in those days was passed on to such as the Rev Sook Pongsanoi and Dr Jinda Singhanetra, leaders of the church in the north, but most important of all, to Rev Boonmark Gitisarn himself.

Thirdly, the results of John Sung's campaigns helped the Thai church to reverse the numerical decline of its membership and brought about its accelerated growth.

Three successive years of declining membership of the CCT from 1934 to 1937 caused concern among the APM and church leaders. For this reason the Five Year Programme was instituted on the model of the Presbyterian mission works in China, Japan, America, the Philippines and other countries for evangelistic endeavor and church growth (The Board of Foreign Missions 1939). The plan was launched in 1938 with two important revival campaigns arranged by John Sung who was the main speaker (Pongudom 1984:83). Smith (1982:197) analysed the statistics of the CCT at that time as follows:

The CCT membership fell for three succeeding years (1935-1937) from 9,421 to 8,408, a loss of 1,013 in spite of the 1,503 added by confessing during that same time. Some of the backsliders were no doubt won back by John Sung. The twelve months prior to John Sung's visit (1937-1938) the Church increased by only five members, while losing 571 members, as was the current pattern during this period.

In 1938, the CCT had 8,413 members. In 1939, after John Sung's visit in 1938, the membership increased to 8,906. Thus the net gain was 493 new members. In 1940, after John Sung's visit in 1939, the membership numbered 9,712 so that the net gain was 806 (Pongudom 1984:84). The membership increase of the year 1940 was "the most in any year since 1914." When we consider the circumstances of the CCT at that time and that the tendency was a continual decrease in membership, John Sung's campaigns "immediately closed the back door" (Smith 1982:197). Two years after John Sung's meetings in 1940, the communicant members of the CCT totalled 9,712. Thus, the net gain in membership was 1,299 (Pongudom 1984:84).

An increase of only 1,299 members in two years throughout the whole of Thailand which had a population of 14,114,709 in 1938 (Seigle, J Y 1939:55) appears insignificant. It would be meaningless in other countries if the whole church population of a country increased by only 1,299 members in two years. But not in Thailand! When we look back at the history of the Thai church from the beginning, the number 1,299 is significant. We can understand the unfruitfulness of the Thai church by noting the description of Herbert Kane (1982:97):

The American Congregational missionaries arrived in 1831 and labored for eighteen years without baptizing a single convert. They became weary in well-doing and withdrew in 1849. The American Baptists had a similar experience. They baptised a few Chinese converts but not a single Thai. After seventeen years of futile effort they withdrew and did not return until after World War

II. The American Presbyterians entered in 1840 and refused to leave, but it took them nineteen years to win their first Thai convert!

If we give consideration to the situation of the early stage of mission work in Thailand and the small percentage of Christians, 0.06 % after 112 years of Protestant mission history, from 1828 to 1940, the number 1,299 is significant. John Sung himself testified that during his visit in the year 1939, "3,000 people were saved" (Sung 1995b:277). Of course, the numbers would include backsliding and nominal Christians. Nobody knows the correct numbers of non-Christians who were really converted at that time, but it is obvious that John Sung's campaigns changed the trend of the Thai church from a decrease in church membership to an increase. A net gain of 1,299 in two years, from 8,413 in 1938 to 9,712 in 1940 (Pongudom 1984:84) which represented a growth of 15%, would have been remarkable but the writer assures us that the real added numbers are more than that, as we refer to *The diary of his spiritual life of Dr John Sung* (Sung 1995b). Samuel Kim (1980:58-59) gave a hint that John Sung's campaigns caused the membership of the CCT church to double between 1938 and 1955, increasing from 8,413 to 16,800.

With these issues in mind, we will now take a look at the relationship between revival and church growth. In his book, *Understanding church growth*, McGavran (1980:186) considers the relationship between church growth and revival:

Revival bears a close relationship to church growth; yet exactly what that relationship is, particularly where the Church is growing on new ground, is often not clear. Under certain conditions revival may be said to cause growth. Under others, its relationship to church growth is so distant that apparently revival occurs without growth and growth without revival.

This remark is very interesting, because it shows that on new ground revival may occur without numerical growth. The Thai mission field is not new ground in terms of the duration of the Protestant church history which has been more than a century from the beginning in 1828, to John Sung's campaigns in 1938-1939. In practice, viewed from another angle we need to treat Thailand as a new mission field. The receptivity of the gospel was the same as a new field notwithstanding the long church history. The revival by John Sung's ministry did not seem to bring numerical church growth from the viewpoint of general historical revival. But it is not to

be denied that the numerical growth of 1,299 in two years is enormous church growth in the situation of the Thai church.

Brian H Edwards (1997:132) bore witness that all revivals are unique in terms of how they affect different cultures and the temperaments of people. All of these factors play their part in revival which occurs in different patterns in different cultures. Likewise, the Thai revival in 1938-1939 did not result in explosive numerical church growth. The Thai church was truly revived and the revived Christians shared the gospel fervently with the non-Christian Buddhists. Many nominal Christians were revived. But it seems that not many Buddhists became Christian. This is partly because the Presbyterian missionaries did not support the revived Thai Christians wholeheartedly. It was also partly due to the fact that the non-Christian Thai were controlled by their traditional Thai social sanctions and therefore they did not respond to the gospel easily. In other words, the revived Thai church could not demolish the strong bulwark of the long-standing Buddhist tradition. Nevertheless, Samuel Kim (1980:62-63) confirmed that the revived Thai church leaders, the Rev Boonmark Gitisarn and the Rev Sook Pongsanoi, and other individual Christians who had been revived through John Sung's ministry played a definitive role in preserving the Thai church courageously during the Second World War although some of the Christians denied their faith.

Fourthly, John Sung's campaigns aroused an eager response towards evangelism in the Thai Christians.

Mien Pongsanoi (1999) witnessed that before the Thai church experienced John Sung's campaigns, they were not interested in evangelism but when Dr Sung came to teach and to evangelise non-Christians they began to reach out to outsiders. Wherever he went, Dr John Sung urged the Thai Christians to organise evangelistic teams and to evangelise non-believers. Dr Chinda Singhanetra (1939b:26-27) testified that at the end of John Sung's last meeting he prayed that the attendees would witness for Christ at least once a week. There were about three hundred people who promised to be active in evangelism at the Chiangmai First Church alone in May 1939. Also there were many people who promised to use their lives to preach the Word of God.

6.2.2.2 Negative results of John Sung's campaigns

Firstly, the McGilvary Theological Seminary closed for nine years, from 1940 to 1949, because the protagonists of John Sung's campaigns wanted to start a Bible College using the compound of the Seminary.

Dr Sung's campaigns raised a great crisis in the history of theological education in the Thai church. The Thai Christians who followed John Sung suggested that there should be a Bible College to teach the Bible. In a way that would be true to Scripture and applied to everyday living. While it may never have been spelled out, there had been an underlying tension between the traditional evangelical understanding of Scripture and the more modern liberal views coming from America (Swanson 1995:101-102). It was evident that John Sung's evangelical high view of Scripture clashed with those who were of liberal persuasion and who had a low view of Scripture (Cort 1940). The call for a Bible College, was a really a call for Bible teaching that was truly evangelical and thoroughly biblical. This was a challenge to many Thai and missionaries at the McGilvary Theological Seminary who had been heavily influenced by liberal scholarship.

The Bible School comprising evangelical Thai leaders, suggested to the APM and the Board of the Seminary that there should be a Bible School based at the McGilvary Theological Seminary, Chiangmai. They asserted that the followers of Dr John Sung should be the ones to teach the Bible to the students. It is no great surprise that the Seminary was not willing to accept this proposal, so a great dispute arose. In the end, rather than encourage this evangelical movement, the APM solved the problem by closing the Seminary, and ordering the Rev Carl Elder, who was the director of the Seminary and an antagonist of John Sung's campaigns, to work in Bangkok (Swanson 1995:107-108). We will discuss this matter in Chapter 6.2.3 again.

Secondly, there was tension within the APM and church.

Paul Eakin, the Executive Secretary of the APM from 1929 (Eakin et al 1955:145), left on furlough on 4 June 1938 and returned to Thailand on 16 August 1939 (:129). He was not in Thailand while John Sung visited Thailand in 1938-1939. When he came back to Thailand he found considerable tension in Thailand. "This continued and got worse. There was tension in the mission and in the church, as a result of the visit of Dr John Sung, the Chinese evangelist. The church was also divided, there was ambitious jockeying for key positions of **authority**...

Everything seemed to be gathering for an explosion" (:130). This clearly shows that there were serious tensions in the church and the APM because of John **Sung's** criticisms of the missionaries and church leaders. The question remains as to whether John Sung's criticisms were truly justifiable or not.

Bunmi Rungrueangwong (1979) also confirmed that what Dr Sung said caused church members to misunderstand elders and missionaries. They in turn accused the Rev Boonmark Gitisarn of ingratitude towards the mission. Some of the elders, pastors and missionaries did not like John Sung because he had criticised them resulting in the fact that some Christians now tended to look down on the missionaries.

Thirdly, it is very possible that John Sung's campaigns may have aggravated the decline of pastoral care in the Thai churches. That tendency continues in the Thai church until the present day.

The Thai church had been short of pastoral care for a long time before John **Sung's** campaigns. It is ironic that the real revival movement may have compounded the problem in the end. Swanson (1995) asserted:

This revival process was not a matter of pastoring the churches. Actually the revival movement dragged pastors out of the churches for which they were responsible, to arrange and share in revival meetings at other churches... This process was leading the church in the pattern of evangelism... There is no pastoring in this. So we suggest that this process derived from an evangelistic model which lacked pastoral care, and which was a weak point in the revival process (:108).

Finally throughout the time when there was the emphasis on revival, the missionaries, the Church of Christ in Thailand and the local churches all failed to find a system of pastoral care for the church that would reach everyone and produce results (: 109).

The campaigns prompted the Thai churches to pull out the pastors from the existing churches in order to arrange revival meetings at other churches. Swanson (Swanson 1995:108) cited the example of Rev Charoen Sakoolkan to show the lack of pastoral care as a result of John Sung's campaigns.

Many contemporary Thai churches follow the pattern that was set in the past. A minister of a church may not be able to care for one local church exclusively. Many Thai Christians however, feel that the churches who do not have full-time ministers should have shared the pastor from another church equally. On the other hand, that custom weakens all the churches in the end whether a church has a full-time minister or not, because the pastor cannot give good pastoral care to his or her own church members and shepherd the flock elsewhere at the same time. Particularly on special occasions like Easter Sunday, Thanksgiving Day and Christmas Day, the church members visit many churches. The pastors and the church members are so busy that they do not have time to look after one another. The Thai church needs to pay attention to this particular result of John Sung's campaigns, namely the lack of pastoral care at the local church level. While this has been postulated as a criticism of John Sung's ministry, his brief visits could have shown up what was already a fundamental weakness in the Thai church, namely lack of adequate pastoral leadership.

Fourthly, John Sung's campaigns encouraged a wrong form of clericalism⁵⁰ in the CCT.

The campaigns enabled the Rev Boonmark Gitisarn to exercise his influence over the CCT. Especially after John Sung's 1939 campaigns, he used his authority as the General Secretary of the CCT to form an informal group of leaders within the church. For instance, he supported **Bunmi Rungrueangwong** from his group as the candidate of the Chiangmai First Church (Pongudom 1984:86-87). He also tried to seize power in the different administrative areas of the CCT by backing people from his own party (:88). However from the other perspective, the reason why Boonmark supported Bunmi Rungrueangwong as candidate for the Chiangmai First Church was probably theological, in that he would have supported someone who had a high view of Scripture to pastor the church rather than a liberal pastor.

6.2.3 Bible College controversy and the qualifications of the ministers

It might appear that the Bible College issue and the problem of the minister's qualifications do not relate to each other. In fact, these two issues are closely related.

⁵⁰ This means the misuse of the power or influence of the clergy in church polity for their own interests or party (Kim 1998:107-111).

6.2.3.1 Bible College controversy

John Sung was not satisfied to have intermittent revivalistic campaigns. He attempted to have an intensive Bible study programme wherever possible which would be a kind of nurture meeting for people who had attended his campaigns before. It was known as the Bible Institute. The Second Bible Institute took place in **Amoy** in China from 10 July to 9 August 1936. There were one thousand and six hundred delegates from all over China and some from overseas. He taught from Genesis to Revelation (Lyll [1954]1965:153-155).

John Sung arranged a series of nurture meetings at the Maitrichit Church in Bangkok for twelve days, from 22 July to 2 August 1939, after nearly two months of continuous itinerant ministry in Thailand in 1939. Night meetings were evangelistic in character, while the day meetings were purely for Bible study (Singhanetra 1939a:165). He taught "the Gospel of Mark, Second Timothy, some Old Testament portions, two chapters on Revelation, and a chapter of the Acts." The Bible became a new book to be studied (: 166).

The participants of the meetings at the Maitrichit Church were eager to study **God's Word** because they had studied the Bible with great interest at the campaigns. Those who attended the campaigns asked the APM to establish the Bible College on 2 August 1939 in the name of one hundred and sixty-six Christians. The date was the last day of the conference. It is not possible to prove that the plan for setting up the Bible College was the idea of John Sung. But it is certain that those present at the meetings discussed and decided to obtain permission to start a Bible College during the campaigns (Bible Conference Bangkok 1939) without the missionaries' initiative (Bassett 1939). It is interesting that there are at least two missionaries' names, i.e., M C McCord, and Forrest C Travaille, among the one hundred and sixty-six signatories. Miss M C McCord and Mr F C Travaille were designated for evangelistic work in Bangkok (Bible Conference Bangkok 1939). Miss McCord was a senior missionary at that time while Mr Travaille was a new missionary who had just come to Thailand in November 1938 (Bangkok 1939:6).

Those who asked to begin the Bible College requested that it open in the McGilvary Theological Seminary, which was the central theological educational institute of the CCT. The group also asked that the Rev Loren S Hanna, who was the strongest protagonist among the APM missionaries, take charge of the Bible School. "In various centers Bible classes are being carried

on to satisfy this ‘longing to grow.’” In some places three Bible classes are being conducted per week (Seigle, A G 1939:163). The desire to study the Bible increased and the Young People's Bible Classes continued once a week in Chiangmai (Singhanetra 1939c:174). Jinda Singhanetra (1939d) said that there were more than one hundred young men and women who were eager to learn the Bible in Chiangmai. He continually emphasised to Paul Eakin that if they did not seize this opportunity, the zeal for studying God's Word would die down. It is clear that many Bible classes continued to flourish in many places.

Rumours arose and misunderstanding grew between the church and the mission (Eakin 1939). Jinda Singhanetra (1939e) insisted that the Bible College would be for the lay leaders and not for training full-time ministers. He had serious doubts about Carl Elder's liberal theological tendency. Loren Hanna (1939a) did not trust Carl Elder's theology either. Once again one can see under the surface a critical cleave between those who held to a high view of Scripture and those who were outspokenly liberal. There was a serious misunderstanding between the group that supported John Sung's campaigns and the Principal of the McGilvary Theological Seminary, the Rev Carl Elder. On 25 September 1939, the people who had supported the campaigns sent a letter signed by forty seven people requesting Paul Eakin to remove Carl Elder from the Seminary. They accused him of obstructing John Sung's campaigns and of interfering with the activities of the witness bands (Christians of Chiengmai 1939). But it is evident that the reasons for obstructing John Sung's campaigns went deeper than just ‘interfering’ with witness bands. They were evidently more theological than methodological.

In attempting to resolve the problems at hand the Board of Directors of the McGilvary Seminary recommended three points unanimously on 31 October 1939 (Elder 1939b). Firstly, it was not possible to operate two Boards at the same time. Secondly, the Board was sympathetic about the request of the group that wanted to study the Bible. Thirdly, the Board asked the Executive Committee of the APM and the Executive Committee of the CCT to cooperate in appointing a special committee for the organising of conferences throughout the church in Thailand. In the end, the Executive Committee of the APM accepted the decision of the Board of the Seminary (The American Presbyterian Mission 1940:18-20). The Committee rejected the original request to start a Bible College. From the decisions, we realise that the Committee of the APM tried to satisfy the Board of the Seminary as well as pacify those who requested the starting of a new Bible College. What is important is that the decision of the APM quenched the eagerness of the Thai Christians to study God's Word that had derived from John Sung's campaigns. They

mistakenly assumed that the substitute of arranging conferences throughout Thailand would satisfy the churches' spiritual desire. Even though some missionaries supported the revival movement of the Thai church covertly, they could not help to change the decision of the Executive Committee of the APM. The APM lost a long-awaited opportunity to contribute to the revival and growth of the Thai church. If the APM had used that opportunity well, the revival movement would have continued in the Thai church.

The APM settled the problem by sending the Rev Carl Elder and Mrs Elder to Bangkok to work at the Bangkok Christian College at the end of 1940 (Fuller 1941). The two Thai co-workers, Kru Banchop Bansiddhi (Elder 1941) and Kru Prasert Inthaphantu, resigned from the faculty of the Seminary. The Seminary closed from that time until 1949 when it was reopened (Pongudom 1984:87).

6.2.3.2 The controversy regarding the qualifications of the ministers

Carl Elder (1940a) asserted that the teaching of John Sung had exerted a bad influence upon theological training. The protagonists of John Sung's campaigns understood that being a minister was not a matter of education but of the Holy Spirit. Anyone whom God had chosen was fit to be a minister, whether he had completed theological studies or not. But Carl Elder (1940a) stated:

The Presbyterian Church has never recognized the right of any except those in the ministerial office to examine and ordain others into the office... This, I say, is the standard of our Presbyterian Church, and is the standard received and accepted by the Church in Thailand from us.

The qualifications required of the minister came to a head when the Chiangmai First Church tried to elect a person who had never had official theological training (Pongudom 1984:87). Carl Elder (1940a) was worried that if the church were to ordain an untrained man, it would be a direct blow to the standing of the Seminary and the standards to which the church had adhered. Also it would discourage men from entering the Seminary and would open the way for the ordination of unqualified men. Carl Elder had threatened to close the Seminary down if the candidate he supported lost the vote for the position of pastor of the church (Pongudom 1984:87). He strongly opposed the ordination of an untrained man as the pastor of the church. He supported Suwan Chaiwan who had finished his studies at the McGilvary Theological Seminary. At that time the members of the church realised that Suwan Chaiwan was young and single, and

as such was not suitable for overseeing the church (:86-87). Therefore the church chose Bunmi Rungrueangwong after he had taken a simple test. Elder was afraid that "it opened the way for the ordination of any man of equal or even less training." In this way, it was said that John **Sung's** teaching damaged not only belief in the need for a trained ministry, but for a well ordained minister as well (Elder 1940b).

From the beginning Presbyterianism has always stressed the necessity of a highly educated ministry to teach the Word of God (Loetscher 1978:66). The Presbyterian law required that all candidates for the ministry must have a degree of Bachelor or Master of Arts from a College or University (Sweet 1965:148). From 1780 to 1830 Presbyterians established thirteen institutions in all parts of the United States among forty Colleges and Universities in the country (: 149). Nevertheless, in American church history when the Presbyterians in the Cumberland region experienced revival in Kentucky, they ordained a deeply religious but uneducated person. The controversy over the qualification of the minister caused the division of the Cumberland Presbyterian Church from the main line churches in 1906 (Smylie 1996:72-73).

Likewise the Thai revival in 1938-1939 brought about problems. As a Presbyterian minister Carl Elder felt that being a minister meant having a theological education as well as being someone with sound knowledge and deep understanding (Swanson 1995:108). On the other hand, people who followed John Sung paid little attention to higher education.

The Bible College issue and the problem of the minister's qualification are correlated. The supporters of the Bible College did not take much account of the scholastic ability of the ministers. It was a matter of their experience of the Holy Spirit. Contrariwise Carl Elder, the head of the McGilvary Theological Seminary and the representative antagonist of John **Sung's** campaigns, insisted upon the higher scholarly attainments requested by the traditional American Presbyterian Church.

6.2.4 An ecclesiological evaluation of John Sung's ministry

The Westminster Confession of Faith (WCF) will be used as the standard in an ecclesiological evaluation of John **Sung's** ministry in Thailand. Even though John Sung is not from a Presbyterian Church background, there is a sufficient reason to use the ecclesiology of the WCF as a criterion to evaluate his campaigns. The CCT and the APM missionaries accepted the WCF

as their confession of faith. The WCF was "designed to unite the English and Scottish churches in their theology" (Hall 1999:276). The Scottish General Assembly adopted the WCF for use in the church in 1647. "In 1729, the standards were adopted as the confessional position of the newly organised Presbyterian synod in the colonies and have played a formative role in American Presbyterianism ever since" (The Office of the General Assembly 1994:122). The missionaries from the PCUSA worked among the Presbyterian Churches in Thailand and thus, naturally, the CCT accepted the WCF as their standard. The writer is also from the Presbyterian Church which confesses the WCF as the standard of the faith.

We will evaluate the ecclesiology of John Sung and his followers according to those elements of the WCF which relate to his campaigns. Chapter 25 (Of the church) will be used, along with Chapter 26 (Of the communion of the saints) and Chapter 30 (Of church censures) of the WCF. The contents of the WCF will be taken from *The constitution of the Presbyterian Church (U.S.A.): Part I book of confessions* published by the Office of the General Assembly in 1994. The WCF (25.1)⁵¹ says that "The catholic or universal church, which is invisible, consists of the whole number of the elect, that have been, are, or shall be gathered into one, under Christ the head thereof..."

This section teaches us "the nature of the Church from the divine point of view" (Williamson 1964:187). The invisible universal church is one. John Sung never instigated division within the church but encouraged people to unite together in the Lord (Lyll [1954] 1965:125-126). Even so, the followers of John Sung tried to separate themselves from other groups. It was alleged that they were under the wrong impression because they saw themselves as special people who were different from normal Christians (Pongudom 1984:84).

The WCF (25.2) says that "The visible Church, which is also catholic or universal under the gospel (not confined to one nation as before under the law), consists of all those throughout the world that profess the true religion, together with their children..."

This section teaches us "the nature of the Church from the human point of view" (Williamson 1964:187). John Sung's teaching caused some Christians to understand the meaning of professing true religion only in terms of regeneration. They claimed that he overstressed the

⁵¹ The former number indicates chapter and the latter number the verse. Thus 25.1 means chapter twenty-five and verse one of the WCF.

experience of being born again (Pongudom 1984:84) so that there was a danger of confining the profession of Christianity to this alone.

The WCF (25.3) states that "Unto this catholic visible Church, Christ hath given the ministry, oracles, and ordinances of God, for the gathering and perfecting of the saints, in this life, to the end of the world..." The WCF (30.1) also says that "The Lord Jesus, as king and head of his Church, hath therein appointed a government in the hands of Church officers, distinct from the civil magistrate." The WCF (30.2) continually maintains that "To these officers the keys of the Kingdom of Heaven are committed, by virtue whereof they have power respectively to retain and remit sin..."

These sections of the Confession teach us that Christ is king and head of the church. He has appointed a government which is in the hand of church officers (Williamson 1964:231) for building up the body of Christ (Eph 4:11-12). John Sung did not admit the authority of the officers such as missionaries, pastors and church leaders unless he felt they were completely dedicated to God's work. It was claimed that he censured missionaries and church leaders too harshly in public as we have seen in Chapter 6.2.2.2. His condemnation of the church officers exerted such an influence that they were left with little authority in the church. He did not acknowledge the authority of the officers as being from the Lord Jesus. His attitude therefore, disturbed the work of the officers of the Thai church.

According to the WCF (25.5), "The purest churches under heaven are subject both to mixture, and error: and some have so degenerated as to become apparently no churches of Christ. Nevertheless, there shall be always a Church on earth, to worship God according to his will."

Philip J Hughes (1989:32) alleged that "in conjunction with his emphasis on purity and separateness, not only from the world, but from Christians who were not pure, this led to widened divisions in the church and among the missionaries." John Sung pursued the perfectly holy church on earth. But "[w]e must recognize that this is a process, and that any church of which we are a part will be somewhat impure in various areas...there will be no perfect churches until Christ returns" (Grudem 1994:875). The church has to make every possible effort to become pure but must needs admit impurity in some areas as recognised by the WCF.

The WCF (25.5) says that "The Lord Jesus Christ is the only head of the Church, and the claim of any man to be the vicar of Christ and the head of the Church is **unscriptural...**"

John Sung never despised the lordship of Jesus Christ over the church in his preaching. Nevertheless, his supporters followed him blindly because they were so impressed by him. Indeed, some followers of John Sung had a tendency to look to him instead of to the Lord Jesus as the head of the church (Col 1:18). It must be said that John Sung never encouraged such a view of himself, either as the vicar of Christ or indeed as someone special.

The WCF (26.1) says that "All saints being united with Jesus Christ their head... have fellowship with him in his graces, sufferings, death, resurrection, and glory: and, being united to one another in love, they have communion in each other's gifts and graces..."

If the Christians recognise the Lord Jesus Christ as their head, they have to be united in love and cooperation (Choi 1998:176-177). John Sung's campaigns, however, stirred up conflict between the protagonists and the antagonists. They could not collaborate in Christian love.

6.2.5 The historical significance of John Sung's campaigns in terms of the development of the church in Thailand

Firstly, there is no doubt that John Sung's campaigns prepared the Thai church for testing during the nationalistic Buddhist movement of 1940-1941 (Smith 1982:196).

Before the Second World War there was a stirring up of nationalism in Thailand as mentioned in Chapter 3.5. The event had no small effect on the Thai church. The government persuaded and pressured the Christians to apostatize their faith. Buddhism was used to build unity in the nation and to make Christians renounce their faith. They resorted to threats, constraints and even exclusion from society. The government encouraged bad feelings towards Western religions, that is, Christianity. We are not able to determine the number who renounced their Christian faith under such pressure (Wells 1958:161), but it was reported by a Thai Christian leader that less than two percent forsook their faith because of Buddhist nationalistic pressure (South-East Asia 1947:18). It is commonly agreed that the revival from John Sung's campaigns helped to build up strong Thai Christian leaders who could lead the church during the nationalistic Buddhist movement.

Secondly, the campaigns equipped the people for the hardship of the Second World War.

Brian Edwards (1997:222) writes that "[r]evival is often a preparation for suffering that will follow, and the suffering itself becomes a test of the quality and reality of the revival." "Revival is seldom primarily for personal enjoyment, and history teaches that the purging fire of renewal is normally a preparation for meeting a fiery trial of suffering" (Lyll 1985:39). This has certainly been so in Thai church history. Jinda Singhanetra declared (1979):

We were greatly empowered by the Holy Spirit, the churches were revived and built up. Because of this, when persecution arose before the [Second World] War as I have told before, many Christians went and became Buddhist monks, but the Church was able to stand because of power brought by the revival under Dr Sung... It was as if God sent Dr Sung to strengthen the position of the Church in the North in readiness.

Before the Japanese troops came into Thailand in December 1941 God prepared the Thai church through the revival of John Sung's campaigns. All the missionaries were expelled from the territory of Thailand and the Thai churches were in the hands of Thai leadership for four years. Pongudom (1996:296) agreed that the Thai church in general encountered very discouraging circumstances during the Second World War. While many leaders of the town church ran away and hid in country villages, others still stood firm in the faith, and these are the ones who affirmed that they had benefited from Dr Sung's revival preaching. Alex Smith (1982:197) added that "the revived church, [and its] spiritual leaders...all came out of the revival. But it must also be said that it failed to stop the denials, reversions, and regressions during the Japanese War (1941-1945). On the other hand, without John Sung's renewal ministry the declension might have been much worse and the church may have sunk under the testing." Sook Pongsanoi (1968:167) asserted:

The reason I say that he was the one God sent is because before Japan asked for its army to pass through Thailand to attack Singapore, Dr Sung came to stir up all the Christians to have a stronger faith, so that each would be eager to speak out about God. His coming at this time caused many Christians to be able to stand firm, unwilling to change their religion when officials who sent people out secretly urged people to change their religion. Those who refused to change their religion were every one of them who had newly repented. God's power flowed into their hearts enabling them to stand steadfast during the Second World War.

I make bold to assert that if Dr Sung had not been commanded by God to rescue the spirits of Thai brethren on this occasion, it is doubtful that there would have been any Christians left during the Second World War (Lawson 1966:128)

Mien Pongsanoi (1999) also testified that during the Second World War Christians became stronger and were able to help themselves as a result of the influence of the revival under Dr John Sung.

Thirdly, John Sung's campaigns helped to prepare those Thai church leaders who were capable of filling posts in the place of missionaries during and after the Second World War.

On 8 December 1941, Japan invaded the coast of south Thailand. The government of Phibunsongkhram agreed to become Japan's ally and declared war against America on 25 January 1942 (Pongudom 1984:90). Before the War there were forty-nine APM missionaries in Thailand (Pongudom 1984:91). All the missionaries returned home and the Thai church had to face the hardships alone from 1942-1945. The churches were confronted by many problems. Naturally there was no choice except to take sole responsibility for the work during the War (Pongudom 1984:104). Nevertheless the Rev Boonmark Gitisarn, the Rev Sook Pongsanoi, the Rev Tongkham Panthupong and a few other leaders who for the most were those influenced by John Sung's campaigns, constantly visited and stirred up the scattered Christians through itinerant ministry (Kim 1980:63). The Thai church leaders urged the Christians who had abandoned their faith to return (Pongudom 1984:93). Following the War, the first Presbyterian missionaries returned to Thailand at the end of February 1946 (Wells 1958:164). On 16 August 1957, the American Presbyterian Mission was dissolved together with the Church of Christ in Thailand after one hundred and seventeen years of mission work since the American Presbyterian Mission had sent their first missionary to Thailand in 1840 (:191). Samuel Kim (1980:63) firmly believed that the "spiritual refining accomplished by Dr Sung's revival ministry just before the war and the hardship stoically endured during the war were essential to the rapid growth of the church after the war." It is certain that John Sung's ministry became a turning point in Thai church history by building up the Thai church leaders. The leaders who were moulded by the campaigns played an important part in taking over the work from the missionaries during the war. The Second World War also provided the Thai church with a good opportunity to demonstrate national leadership. The hardship of the War became the priming

power to prepare the Thai church leaders to take over the responsibility of the Presbyterian missionaries in 1957.

6.3 An analysis of John Sung's theology of revival

John Sung was not a theologian and "he never hesitated to enter into controversy in defense of what he saw to be the truth. He held his convictions with great tenacity" (Lyll [1954]1965:146). He never wrote **theological** books and yet he expressed his theological viewpoint clearly. We cannot classify his theology of **revival** completely. And yet we are able to understand his theology of revival quite clearly from his sermons and some other written materials. It is clearly possible to divide his theology of **revival** from his methodology of evangelism.

6.3.1 Theology of revival

There are characteristics that are common to **all** revivals, **but** every **revival** is unique (Edwards 1997:93). Revivals do not recur according to the same pattern (Edwards 1997:132). Revival **may** begin in different types of meetings. Sometimes a revival starts in a small prayer meeting or it may happen in a preaching service. "It may happen when an evangelist is holding a series of regular **meetings**...**There** is no limit to the ways in which it may start" (Lloyd-Jones 1986:109). John Sung planned evangelistic campaigns in Thailand which developed into the greatest revival movement in Thai church history from the beginning to the present.

John Sung never accepted that human beings can create revival. On the other hand Charles Finney firmly believed that revivals could be created by following a set of rules, a position that Brian H Edwards (1997:31) affirms is "quite contrary to Scripture; revival is something God brings about." D Martyn Lloyd-Jones, the foremost supporter of the Old School views of revival in the present century, has argued that the churches have forgotten what happened under a different emphasis when they place a modern man-centred emphasis on mass evangelism. He believes that a more Calvinistic faith would enable Christianity to experience more revival (Murray 1998:75). The Old School people understand that the man-made approach to revival is not biblical since God brings revival, not human beings. Basically, John **Sung's** theology of revival is the same as the theology of the Old School. He relied on the Holy Spirit in his ministry instead of depending on evangelistic techniques or humanity's power (Tow 1988:55-56). He understood that man can do nothing if the Holy Spirit does not help as we have seen in Chapter

4.4.6. From his doctrine of the Holy Spirit, we can conclude his theology of revival, namely, that revival is truly God's sovereign work.

We see the difference between the above approach and a successful man-centred mass evangelistic campaign and revival. After finishing mass evangelism the world goes on its way and the dance and picture-shows are still crowded. While in contrast, in true revival the fear of God lays hold upon men and women in the church and community (Campbell 1954: 15). D Martyn Lloyd-Jones (1986:112) believed that human beings can produce evangelistic campaigns but they cannot produce a revival. He deplored the impact of Charles Finney's theology of revival in church history. The whole church has been led astray by Finney's wrong teaching that revival can come at any time whenever **the church** fulfills the necessary conditions. Some Christians have followed the guidelines of Finney, but there has still been no revival. D Martyn Lloyd-Jones concluded that "[a] revival, by definition, is the mighty act of God and it is a sovereign act of God." We can draw the conclusion that D Martyn Lloyd-Jones' understanding of revival is the same as that of John Sung, that is, the Old School view of revival.

We can sum up John Sung's theology of revival in two points: the Word of God and Evangelism. John Sung preached once in Singapore that "[i]n my work for the Lord, I merely witness and expound the Bible, these two things" (Sung [s a], 7:13). For the most part John Sung gave expository sermons wherever he went. After his ministry he focused on building up witness bands.

The total acceptance of Scripture as the Word of God has characterised those whom God used in revival in church history (Edwards 1997:65-66). Calvinists use the Word of God rather than any knowledge of psychology (Murray 1994:184). John Sung was a **Calvinist** in this sense. His emphasis was on the power and authority of God's Word and the reading of the Bible. He read eleven chapters of the Bible every day and thirteen on Sunday. He kept this habit continually and without a break to the end of his life. John Sung used the Bible more than anything else for solving the problems of his life. He believed the Bible to be infallible and **inerrant**. He rarely referred to visions and dreams in his sermons though he had experienced those during the days of spiritual conflict (Tow 1988:38). In the pulpit nothing was more important to him than to declare the Word of God. (Lyall [1954] 1965:192). He alleged that "[h]ead knowledge of Bible truth without heart knowledge is dead knowledge" (Tow 1988:29).

The first thing John Sung did to mobilise the whole church after his ministry was to organise preaching bands. (Tow 1988:52) D Martyn Lloyd-Jones (1986:102) asserted that this is one of the true characteristics of genuine revival. One of them is that the revived Christians have a great concern about others who do not know God and witness about God to them. John Sung stressed evangelism on the grounds that souls are infinitely precious. He urged the people that "God loves the souls of the righteous. Beloved brothers and sisters, God regards the souls of ten righteous men as more precious than the whole world" (Sung [s a], 3:6). If a Christian does not witness he will not grow spiritually (Sung [s a], 5:26). A truly **born-again** Christian is supposed to evangelise to non-believers (:30). "Every Christian should regard winning souls as a personal responsibility, like paying one's debts" (Sung [s a], 8:25).

6.3.2 Methodology of evangelism

Most of John Sung's evangelistic methods are basically in line with the theology of revival of the Old School except for his recording of the numbers of converts and using the invitation system. There is room for criticism in his use of these methods.

Wherever John Sung lead meetings he never allowed the host church to use money to advertise his campaigns. When he led meetings in Singapore in 1935, not a single dollar was spent on publicity. Timothy Tow (1988:56) offered the following explanation:

He forbade having his photograph displayed anywhere, not even in magazines! He had no advance party but the fear of a Holy God going before him. He had no soloist, no army of counselors, no battalions of songsters. He had God with him, in power.

He made no attempt to impress people through advertisement of his meetings (Lyll [1954] 1965:192). We cannot explain revival in terms of the methods used. "No preliminary **advertising**...And yet the thing happens." "No great crowds, no band, no choir, [and] nothing whatsoever" can be found in a real revival. No prelude advertising (Lloyd-Jones 1986:113).

We can **find** two problems in John Sung's evangelistic methodology, namely the numbering of converts and the use of the invitation system.

John Sung came from a Methodist background. This may be the reason we can find records of the numbers of the believers in his diary. It is incredible how he could count the numbers every time. He was a genius and a scientist for he could use special methods in counting the converts. Iain H Murray (1994:184) explained:

Prior to 1800, Methodism in America - despite its concern not to admit any into church membership prematurely - had begun to record the number of supposed converts at particular services. This was a practice studiously avoided by the older evangelicalism, and it was not used by John Wesley. How converts were counted is not always clear.

We do not know his motivation for counting the numbers of the converts all the time particularly since it is impossible to know who the real converts are and who are not.

When he organised witness bands, many teams were brought to the platform one at a time and he prayed for them (Schubert 1976:56). He also used quite an interesting invitation system. This is called *altar service*. "He asked searching questions. He would name sins, and have seekers all over the big church raise their hands when he mentioned their particular sin (Schubert 1976:52). The Rev Boonmark Gitisarn (1979) remembers John Sung's meetings in Thailand:

After the sermon was over there was a time of confession, anyone wanting to confess came out to the front, and many did so. For some it was about smoking, drinking, gambling, lying, and stealing. Some raised their hands and did not take them down, holding them up throughout, inasmuch as to say, "We are confessing all these things."

They confessed their sins because Dr Sung had to have this time of confession wherever he finished preaching, and all those who wanted to confess sins went and put up their hands to say what they had done, and Dr Sung would mention this sin or that, such as adultery, drinking, smoking, things like that, and then people would gradually raise their hands to confess. But some, well, they confessed sins till there was nothing left! But it was good.

It has been asserted that John Sung used quite similar evangelistic methods to Charles Finney. Charles G Finney "highlighted the place of human effort in obeying divine laws to promote religious awakenings" by using highly criticised methods [or measures] to achieve results of the revival. We call it the *New Measures*. Charles Finney did not invent this evangelistic method; it was used for over two decades by the Methodists before him. The New Measures use direct and

often public pressure on individuals, sometimes by name, who are pressed for an immediate decision about conversion (Fraser 1990:817).

D Martyn Lloyd-Jones (1972:265) raised the question "whether we should do anything to condition the meeting and the people for the reception of our message." He alleged that using the New Measures is wrong. He gave several good reasons for his opinion (Lloyd-Jones 1972:271-276). Firstly, to put direct pressure on the will is wrong. Secondly, too much pressure on the will is dangerous because in the end the response of the man who 'comes forward' does not relate not so much to the truth itself as to the personality of the evangelist, or some vague general terror, or some other kind of psychological impact. Thirdly, "the preaching of the Word and the call for decision, should not be separated in our thinking," this being like the teaching of the Reformers that Sacraments should not be separated from the sermon of God's Word. Fourthly, this method projects the wrong connotation that sinners have an inherent power of decision and of self-conversion. Such teaching cannot be reconciled with the teaching of the Bible such as that of 1 Cor 2:14. Fifthly, "the Evangelist somehow is in a position to manipulate the Holy Spirit." Sixthly, "this method tends to produce a superficial conviction of sin, if any at all." Seventhly, by doing this we are encouraging people to misapprehend that their act of going forward somehow saves them. We need to give ear to D Martyn Lloyd-Jones again (Lloyd-Jones 1972:282).

Or, if they have found salvation and are rejoicing in it, they will want to come to tell you about it. They will do so in their own time; let them do so. Do not force these things. This is the work of the Holy Spirit of God. His work is a thorough work, it is a lasting work; and so we must not yield to this over-anxiety about results. I am not saying it is dishonest, I say it is mistaken. We must learn to trust the Spirit and to rely upon His infallible work.

From D Martyn Lloyd-Jones' explanations, we realise that **calling** for decisions has many problems. It is as difficult to support John Sung's altar service as it is to support the New Measures of Charles Finney.

6.4 Useful lessons to learn from John Sung's campaigns

A Chinese proverb states that "A crisis (危機) is an opportunity (機會)." The Thai church encountered a crisis through the revival by John Sung's campaigns. Although the crisis could

have been a good opportunity if grasped, the church failed to make use of it. We will consider the lessons for the APM first and then discuss the lessons for the Thai church.

6.4.1 The lessons for the American Presbyterian Mission

There is no room for doubt that many missionaries, their supporting churches in the United States, and the Thai Christians had been praying for the revival in the Thai church. Miss Margaret C McCord believed that her prayer of thirty years for the revival of Thailand had received an answer when she saw the Chinese Christians in Thailand aroused by John **Sung's** campaigns in 1938. She prayed, "Lord, send a revival!" (Lyll [1954]1965:162). God really answered her prayer for the Thai church. There are numerous evidences from the missionaries and Thai Christians that they experienced genuine revival through John **Sung's** campaigns. It is not possible to count the number of the protagonists among the Presbyterian missionaries. Nevertheless, there is no doubt that many missionaries supported John Sung's campaigns both overtly and covertly.

It is true that a crisis started off because of John Sung's criticisms of some missionaries and some Thai church leaders. This criticism caused strained relations between members of the APM, between the mission and the CCT and within the church itself (Cort 1940). Somehow the missionaries could not handle the problem in time, because of many constraints. Some of these were the love of tradition, theological prejudices, having a negative preconceived idea of John Sung, a lack of administrative ability, and a gross defect in mission strategy.

The Thai church could not ensure the best results from the campaigns because the APM missionaries, especially the leaders, did not support the movement and cooperate in harmony. In the long run the Thai churches lost a good opportunity to grow spiritually and numerically. In his book, *Revival!*, Richard O Roberts (1991:115-119) points out that "the most common obstacles to revival are the *five false loves*". The first false love is the love of tradition. The APM missionaries who were antagonists of John **Sung's** campaigns loved their tradition. They could not accept the different traditions of John Sung. His preaching style, some parts of his theology, his Chinese accented English, and liturgical forms were so different from the Presbyterian missionaries. They were biased against John Sung before they ever saw him directly because they had heard rumours about him that wherever he went he caused division. The leaders of the APM did not support administratively the eager desire of the Thai Christians to study **God's**

Word. They suggested the temporary remedy of having conferences in the mission stations, a measure which could not gratify the national Christian's spiritual desire to know God's Word. In the end the APM could not overcome the limitations and so lost a golden opportunity to see the church grow. They were so engulfed by the problems that they could not see the opportunities. Paul Eakin, the Executive Secretary of the APM, did not demonstrate his leadership effectively. If he had displayed his leadership positively instead of sitting on the fence and if the APM could have seen the opportunity first, rather than the problem, there is no doubt that the Thai church could have grown dramatically.

Dr C H Crooks ([s a]:1) analysed the mission strategy of the APM from the beginning. The APM contributed pioneer social development to the Thai society through many kinds of services and institutions, such as schools, hospitals, leper asylums and a printing press. Simultaneously a missionary (Interpretation of the statistics for Siam [s a]:2) investigated the growth of the educational work of the APM systematically. The educational work began to grow especially after 1911 when there were 37 mission schools and 800 students. By 1925 there were 53 schools and over 3,000 students. After another ten years there were 65 schools and 5,500 students. The APM were honored by the Thai government for their contribution to education. Many ordained missionaries designated for evangelistic work were of necessity drawn into full-time or part-time school work. Therefore the increase in communicant church members between 1925 and 1935 was only 350. This wrong mission strategy of the mission caused the numerical growth of the Thai church to be retarded. When we take a look at the distribution in classes of work of the APM (Siam missionary personnel [s a]:1) in 1930 and 1939, we will realise the serious problems of laying disproportionate emphasis on the educational work of the mission. In 1930, there were only 29 missionaries engaged in evangelistic work out of 93 missionaries, i.e., 31%. In 1939 the mission designated only 24 missionaries out of a total of 68 church work, which was 35% only. For that reason criticisms were leveled and there was serious concern regarding what can now be seen as a misguided mission philosophy within the APM.

We cannot deny that the mission made a real contribution to the life of the Thai people. However, as time went on the auxiliaries became more important than the church planting work itself. Dr C H Crooks said that "[i]n the beginning this was certainly not the plan." He continually expressed his disappointment regarding the wrong mission strategy of the APM (Crooks [s a]:1):

We may now say that the work established by the church as auxiliaries has now a wide influence, but the center or the core that is the church itself, is often weak and almost unknown...But now we must try to strengthen from the inside and bear in mind and not forget the things that have caused the weakness in our church here in Siam in the past.

The natural result of this, erroneous strategy was that the personnel including both the missionaries and the national workers attended to the demands of the educational work first so that the workers neglected to do their church work. As a matter of course they were not able to invest finance for the evangelistic work. In the end the APM suggested to the Board of Foreign Missions of the Presbyterian Church in the United States of America (1939) that they produce lay leaders and Thai evangelists by starting Bible training schools or Bible training courses. There was such a shortage of national workers for the evangelistic work.

In his book, *History of the pastoral care of the church: Church of Christ in Thailand, Draft version*, Swanson (1995) explained the cause of the lack of pastoral care in the CCT historically. When the revival began with John Sung's campaigns, the Rev Sook Pongsanoi (1939:23) pointed out the urgent necessity of shepherding both for the converted backsliding Christians and newly born Christians. The APM and the CCT could not harvest the fruits of the revival in time. If the APM had used efficient mission strategy for church planting, and produced native workers instead of excessive investment of their personnel and finance in the auxiliary works and institutions such as education, medical care, leper asylums and the printing press, the Thai church would have produced enough national church workers to reap the converts of John Sung's campaigns in time. It is really a matter for regret that the APM and the CCT missed a good opportunity to grow dramatically because of an erroneous mission philosophy after 1911.

6.4.2 The lessons for the Thai church

First of all the CCT did not have many matured Christian leaders. They could not exercise self-control when they saw the wonderful results of John Sung's campaigns. The Thai protagonists of the revival movement needed self-control so as not to arouse the other party's antipathy. It was too extreme to suggest starting a new Bible School at the same compound of the McGilvary Theological Seminary, the only official training centre of the CCT. Prasit Pongudom (1984:87) pointed out that the Thai Christians had still not discovered the correct guidelines and the principles by which Christians should live for themselves. None the less, we do not concur with

the evaluation of Prasit Pongudom when he says that the followers of John Sung were still holding onto the patterns of religious observance of their original beliefs of Buddhist and Hinduism. It is not to be denied that the Thai Christians easily approved and followed John Sung possibly because of their lack of clear understanding of Presbyterian doctrines. However Prasit Pongudom goes too far when he understands that the Thai Christians followed the patterns of their original superstitious religious pattern. If the Thai church could have produced many good Christian leaders for over one hundred years of Protestant church history, the church would have been able to assimilate the situation well and could have used the occasion to revive and grow.

Secondly, there is evidence that the Thai church leaders tried to use the occasion for their own party's advantages. There is, for example, room for speculation that the Rev Boonmark Gitisarn had a desire to exercise authority in the CCT. He also is open to question in what was perceived to be his desire to seize the power in the McGilvary Theological Seminary by setting up a new Bible College plan. When the goal of setting up a Bible College did not meet with success, he tried to influence Chiangmai First Church by supporting a person of his group, Bunmi Rungrueangwong, as a candidate of a pastor of the church (Pongudom 1984:85-87). Most of us would accept that the Rev Boonmark Gitisarn had a mixed motive when we investigate his subsequent methodology. The point to observe is that the leaders of the CCT including the Rev Boonmak Gitisarn should not have used their political authority in the church for their own interest but instead should have used their influence for building up strong churches with pure motivation.

6.5 Summary and conclusion

Most Thai Christians and many APM missionaries were the protagonists of John Sung's campaigns. They unanimously accepted the campaigns as evidence of a genuine revival movement. On the other hand some Thai church leaders and APM missionaries were antagonistic because of various reasons such as rumors that John Sung was a separatist, his critical attitude toward undedicated Christians, his different style of preaching, his autonomous spirit and different theological viewpoints. But it is our conviction that the theological differences between John Sung and his antagonists may not have been the main motivation against him. Certain other external factors contributed to this. Outside persons and movements such as the Biederwolf Evangelistic Campaigns, Frank Buchman and the House Party Movement, the Burmese Gospel Team, and Paul Lyn, influenced the Thai Christian leaders. But the Thai

Christian leaders were most deeply involved in John Sung's campaigns. The leaders of the outside movements used the invitation system and evangelistic methods which posed theological problems for the APM missionaries. But these things did not become issues in their context because they did not criticise the missionaries and the church leaders.

John Sung's campaign was a real spiritual revival in the true sense of the term. It also helped to develop the self-confidence of the Thai church and leaders, stimulated numerical growth and aroused the spirit of evangelism in the Thai church. At the same time the McGilvary Theological Seminary received such a severe blow that the operation was halted for several years. Relations were strained within the church, and the APM mission and between the church and the mission. Ironically, the campaign resulted in a lack of pastoral care too. Nevertheless, the positive fruits undoubtedly surpassed the negative results.

The Bible College controversy arose out of the zeal of those Thai Christians who had attended John Sung's campaigns to study **God's** Word. They eagerly tried to start a Bible College with the support of the APM. But the APM turned down the request to start the Bible College and agreed instead to have conferences throughout Thailand. Excessive learning was not regarded as an important necessity of a minister for this group. The collision of these two different groups brought about the closure of the McGilvary Theological Seminary for several years. The Seminary would have probably closed in any case during the Japanese invasion of Thailand from December 1941 to August 1945.

On the other hand, the traditional Presbyterian view of missionaries required high scholastic ability on the part of the minister. Such a view could be regarded as ecclesiastical colonialism imposed by the Western missionaries. One of the most frequent criticisms made of missionary work which originating in the West, is that it was done for imperialist reasons (Verkuyl 1978:168). "Ecclesiastical colonialism is the urge of missionaries to impose the model of the mother church on the native churches among whom they are working rather than give the people the freedom to shape their own churches in response to the gospel" (Verkuyl 1978:169). Carl Elder's high standards for the Thai ministers could also be regarded as an example of ecclesiastical colonialism from the Presbyterian system of America. His goal for the Thai full-time ministers was not suitable for the Thai church as the standard of education of the Thai society was very low at that time, 1930s. The missionaries from the PCUSA were elite even in

America in those days (Swanson 2002). He wanted the Thai full-time ministers to be the same level as the full-time ministers in the United States.

There are valid reasons to use the WCF for an ecclesiological evaluation of John Sung's ministry in Thailand since the Thai church, APM and the writer all confess the Confession. When we apply Chapter 25, 26 and 30 of the WCF as the basic foundation for ecclesiological evaluation, the division which took place after John Sung's criticism of the missionaries and Thai church leaders was a most serious problem. This was not his intention for the Thai church, but as a result of the criticism division among the Christians which was unavoidable. Encouraging a party spirit can be a dangerous aspect of revival. Certainly, revival movements throughout church history have been weighed down by such potential conflict. In American revivals we see the Old School versus the New School; the Old Measures pitted against the New Measures (Roberts 1991:96). All nonessential controversial issues become prominent during revival. (:97). There is a strong emphasis in the New Testament on the unity of believers unless differences arise involving serious heresy in which the Christian faith itself is denied (Grudem 1994:877).

John Sung's campaigns have important significance in Thai church history. They prepared the church for testing during the nationalistic Buddhist movement of 1940-1941 as well as in the hardships of the Second World War. It also helped to equip the Thai church leaders who took over from the missionaries during and after the Second World War.

John Sung's theology of revival is coincident with the Old School but some aspects of his evangelistic methods, such as counting the converts and using the invitation system, are identical with the New School. His evangelistic methodologies do not harmonize with his theology of **revival**. Nevertheless, God has often **used** people who passionately strive to serve Him, despite their errors. God does not demand that a person should be perfect in every part, but he does expect him or her to long for God above everything (Edwards 1997:70). One of the facts of revival is that God uses people whose theology may be erroneous in some respects. John Wesley's doctrine of sinless perfection could be given as an example here, as could Charles Finney's mistaken idea that revivals could be guaranteed if only people created the right conditions. But God used such men in spite of their weaknesses (Edwards 1997:71). Despite John Sung's errors, God used him mightily for the Thai church.

Several useful lessons for the APM and the Thai church can be found. John **Sung's** campaigns represent the biggest revival movement in Thai church history up to this present time. But the APM and the CCT could not seize the opportunity of revival in the Thai church because of their own inhibitions. The most important reason is that neither of them could work in close cooperation with the other. If we take the case of the Korean revival of 1907, the missionaries and the indigenous churches united their efforts to preserve the fruits of the revival. In fact, the missionaries from the Presbyterian Churches and the Methodist Churches even cooperated (Park 2000:18-19) to pray for a great blessing upon Korean Christians before the Korean revival of 1907 (Blair & Hunt 1977:67). The missionaries and the national Christians met together and cried out to God earnestly. "They were bound in spirit and refused to let God go till He blessed them" (Blair & Hunt 1977:71). While in the Thai church, there was no collaboration in the matter of the revival, even within the same missionary group and the same denomination that is, the American Presbyterian Mission and the Church of Christ in Thailand. The antagonists and the protagonists of John Sung's campaigns among the APM and the CCT should have accepted the other side more **open-mindedly**. One party did not show a willingness to accommodate the different perspective of the other side while the other went to the extreme of separatism.

Frederick J Heuser (2000:105) said:

The lessons of history are not quite as tangible as the Ten Commandments or the Sermon on the Mount, even though we might like them to be. The most important lessons that we learn from our past are the ones we consciously chose to learn, shaped by a willingness to develop and use a historical perspective to understand the present. The lessons of history are not learned passively.

The central issue is whether the Thai church can use the lessons of their past. Hopefully, they can learn a great deal from their past if they are intent on using a historical perspective to solve current problems.

Even though John **Sung's** campaigns lasted altogether just over three months in the Thai church about sixty years ago, he is still the most influential figure in the Thai church history of about 170 years, from 1828 until now. He was neither Thai nor American. He was a Chinese and a scientist who did itinerary evangelism throughout China and South-East Asia, but he made a deep impression on the Thai **Christian's** mind, an impression that has lasted to the present. "We cannot always discover a reason why a particular revival came to an end" (Edwards 1997:229).

But in Thailand it is possible to find the reason why the Thai revival of 1938-1939 was discontinued. More than anything else the revival stopped because the APM and the CCT did not work in close cooperation for the same goal, that is, the revival of the Thai church.

6.6 Final observations and summary

Through this study we have sought to attain our goal which relates to an ecclesiological analysis and evaluation of the Thai revival of 1938-1939 among the Presbyterian Churches of Thailand. We have taken into account the available data and have furnished the most detailed comprehensive analysis yet attempted for the Thai church.

Most Thai churches had connections with the APM during the period 1900-1941 because the majority of missionary work until the Second World War was carried on almost exclusively by American Presbyterian missionaries. The Thai revival of 1938-1939 through John Sung's itinerant ministry, which occurred all over the country, was confined to the CCT churches with which the missionaries of the APM were involved.

Chapter 2 and Chapter 4 are both complementary and auxiliary parts that help to understand the other chapters more fully. We came to understand the general backgrounds of the APM missionaries by surveying a brief history of the disunion within the American Presbyterian Church in the U.S.A. Studying the schism of Old-New Side Presbyterianism of 1741 and of Old-New School Presbyterianism of 1837 has helped to apprehend the different interpretations of the meaning of revival among the missionaries of the APM. It is both noteworthy and surprising to see that there is an interesting resemblance between the Old-New Side split of 1741 in the American Presbyterian Church and the Thai revival of 1938-1939. The famous representative protagonist and antagonist, the Rev L S Hanna and the Rev C Elder, had experienced the same problems as their forefathers in America. The two APM missionaries in Thailand had different concepts regarding ministerial qualifications, revival, and the nature of true faith. In Chapter 4 we examined John Sung's life, ministry, characteristics, theology, and impact in Southeast Asia. The Holy Spirit did tremendous work through John Sung's ministry wherever he went, both in China and abroad, in spite of his weaknesses. Thousands of people were saved through a genuine spiritual revival resulting from his campaigns. John Sung was conservative in his theology and therefore objected to liberal theology and the Social Gospel.

The resultant fruit of John Sung's ministry was amazing in Thai church history, but it was meagre compared to the results of his work in other countries. Historical factors brought together the cohesive power of a nationalistic spirit which included almost blind devotion and allegiance to royalty. Socio-cultural factors contributed to create an integrated and unified culture which resisted Christianity most effectively. Their identification of Christianity as a foreigner's religion is still the most serious obstacle to acceptance of the gospel among contemporary Thai people as with their ancestors. Thai Theravada Buddhism amalgamated with Animism and Brahmanism and all three belief systems exist harmoniously without conflict. This can be understood within a holistic theology. The militaristic, economic, and cultural expressions of Buddhist nationalism affected the Chinese more than the Thai during John Sung's campaigns. We may conclude with caution that these social pressures contributed as positive factors to receptivity to the gospel.

Thai Protestantism has been a minority religion even though it has been present for more than 170 years. The APM missionaries from the PCUSA who were cooperating with the CCT were the largest group. The newly established national church in 1934 prepared the foundation for John Sung's ministry, through the forerunners of the revival movement. By investigating all related historical facts, we came to the conclusion that these antecedent revival movements which were the precursors of John Sung, were those which influenced and brought about the genuine spiritual revival of 1938-1939 through John Sung's campaigns. His campaigns of 1939 had a greater influence on the Thai church than the 1938 one. Even though his preaching style was not the same as that of the American missionaries, repentance, confession of sins, and a thirst for God's Word were witnessed to be, similar to those in the true historical spiritual revivals throughout the history of the church. His main emphasis was the cross of Jesus, evangelism and the Bible. The revival mainly impacted among those already professing Christ but it did not achieve a change in the structure of the church.

While the protagonists recognised the campaigns as genuine revival, the antagonists, on the other hand, did not accept that, not because of a theological discrepancy but because of certain external factors such as inaccurate rumours about John Sung, his critical attitude to the leaders of the mission and the church, and his different style of preaching. When we analyse John Sung's theology of revival, we begin to see the facts more clearly. His theology of revival was equivalent to the Old School Presbyterianism. He understood that man cannot create revival but only God the Holy Spirit can be the effective cause of it. However, he used the evangelistic methodologies of the New School Presbyterianism, such as using the invitation system and

counting the converts. The revival had both positive and negative results. The former outcomes related to a growing sense of responsibility and self-confidence of the church and its leaders, acceleration of numerical growth and the emergence of a spirit of evangelism. The latter consequences were the closing down of the McGilvary Theological Seminary for several years, through conflict within the church and the mission; decline of pastoral care especially among those who had been effected by the revival; and the emergence of a struggle for power among the Thai church leaders.

When the Thai supporters of the campaigns asked for the Bible College to be established, the problem of ministerial qualifications followed as it had in the American Presbyterian Church. The leaders of the APM were not willing to bypass these nonessential controversial issues. They lost a long-awaited golden opportunity to build a strong Thai church both quantitatively and qualitatively. Through an evaluation of John **Sung's** campaigns using the ecclesiology of the Westminster Confession of Faith, we found that the issue of division within the church had not been John Sung's original intention at all. The missionaries looked at the problems first, instead of grasping the chance of revival, because of their limitations or reservations resulting from various issues such as their love of tradition, their theological prejudices, and their lack of administrative ability. There was also the issue of an unbalanced mission strategy which was brought about by the preoccupation with social and educational work of the APM, and this aggravated the situation. Because of their wrong mission strategy, the mission failed to prepare mature Thai Christian leaders, which meant that there were not enough mature Thai Christians to help the new converts of the revival. Furthermore the missionaries and the Thai church leaders did not cooperate in the matter of the revival, and it was evident that there was a lack of harmony even among themselves. As a matter of course both the APM and the CCT missed grasping hold of the opportunity of the revival. Nevertheless John Sung's campaigns have important significance in Thai church history, because his ministry helped the Thai church stand **firm** during the hardship, resulting from the Buddhist nationalism of **1940-1941** and of the Second World War. Despite his weak points, God used his ministry greatly for the Thai church.

The greatest revival movement in Thai church history could not continue because of many reasons as we have shown above. Collaboration in the revival would not have been an easy matter. Yet the APM and the CCT should have aided one another toward one of the first objectives of the Thai church, namely, the revival of the church. The APM missionaries failed to learn from their past experience of two-hundred years earlier in their home country. The writer's

intention in writing this thesis is that the contemporary Thai church and the missionaries may learn the lessons of the past, be instructed to have faith and be encouraged to pray for another revival in the Thai church in the near future. Only the Holy Spirit can help the Thai to see the truth of Jesus Christ. "Oh Lord, help them to realise their spiritual potential and experience revival again!"

Lastly, there are other areas of research that could be beneficial as a separate study, which this thesis could not consider. Among these are:

- (i) Some other revival movements in Thai church history after the Thai revival of 1938-1939.
- (ii) Comparison between the Korean revival of 1907 and the Thai revival of 1938-1939 which took place among the same groups of missionaries of the PCUSA.
- (iii) Research into how the missionaries and Thai church leaders interpreted and used Scripture within the revival movements and how they utilised the Bible as a basis for their theological arguments would also provide a very interesting study.

BIBLIOGRAPHY

* Dates pertaining to the Buddhist Era have been changed to AD.

* Where more than one letter was written to the same recipient in a single year, the date appears in parenthesis.

- A convention symposium 1906. A convention symposium, in *The Laos News*, Vol. 3, No. 3, July. 30-32.
- Ajharn, T (จากหาญ, ทนง) 1939. Testimony from Nakorn Pathom (พยานจาก นครปฐม), in *The Church News (ข่าวคริสตจักร)*, Vol. 10, January. 30-32.
- Bangkok 1939. Bangkok, in *The Siam Outlook*, Vol. 10, No. 1, January. 6-15
- Bangkok Station 1925. Bangkok Station, in *The Siam Outlook*, Vol. 4, No. 3, January. 66-82.
- Bansiddhi, B (บัณฑิต, บรรจบ) & Intaphantu, P (อินทะพันธุ์, ประเสริฐ) 1939. Letter to P Eakin (พล เอกิน).
- Bassett, A 1939. Prayer changes things, in *The Siam Outlook*, Vol. 10, No. 4, October. 168-170.
- Beckham, W A 2000. *Redefining revival: Biblical patterns for missions, evangelism and growth*. Houston, Texas: Touch Publications.
- Beek, S V (ed) 1983. *M.R. Kukrit Pramoj: His wit and wisdom writings, speeches and interviews*. Bangkok, Thailand: Duang Kamol.
- Bible Conference Bangkok: Some attendants 1939. Letter to the American Presbyterian Mission in Siam.
- Blair, W N & Hunt, B 1977. *The Korean Pentecost and the suffering which followed*. Edinburgh: The Banner of Truth Trust.
- Blanford, C E 1975. *Chinese churches in Thailand*. Bangkok, Thailand: Suriyaban Publishers.
- Bosman, H L 2003. Interview with author. Stellenbosch, South Africa.
- Bpromkarn, P 1941. Letter to the Christian citizens.
- Bradly, J E & Muller, R A 1995. *Church history: An introduction to research, reference works, and methods*. Grand Rapids, Michigan: William B Eerdmans Publishing Company.
- Breazeale, K [s a]. *The English missionaries in Thailand*. S 1: Breazeale, printers.
- Briggs, W A 1905. Another Laos Convention, in *The Laos News*, Vol. 2, No 4, October. 93-94.
- Brown, L (ed) 1993. *The New Shorter Oxford English Dictionary: On historical principles*. Vol. 1. Oxford: Clarendon Press.
- Buss, C A 1958. *Southeast Asia and the world today*. Princeton, New Jersey: D. Van Nostrand Company, Inc.
- Calvin, J 1960. *Calvin: Institutes of the Christian Religion*. 2 vols McNeill, J T (ed). Philadelphia: The Westminster Press.
- Campbell, D 1954. *The Lewis awakening 1949-1953*. Edinburgh: The Faith Mission.
- Carre, E G (ed) [s a]. *Praying Hyde: A present day challenge to prayer*. London: Pickering & Inglis.
- Chaiwan, S 1985. A study of the impact of Christian missions on Thai culture from the historical perspective (1662-1985). ThD thesis, The Graduate School of the Presbyterian College and Theological Seminary, Seoul (Korea).
- Chaney, C L 1984. *Church planting at the end of the twentieth century*. Wheaton, Illinois: Tyndale House Publishers, Inc.
- Choi, B S (최병섭) 1998. *Theologumena Reformatarum Confessionis (개혁파신조서들의 신학 사상들)* Seoul (서울), Korea: Saesoon Publishing Co. (새순).
- Christians of Chiengmai 1939. Letter to P Eakin.
- Class III. Force list (Siam Mission) [s a]. Class III. Force list (Siam Mission). S 1: s n.

- Collins, D G 1912a. Great awakening within the bounds of the Bethlehem Church, in *The Laos News*, Vol. 9, No. 2, April. 60-65.
- 1912b. Large ingathering in the Bethlehem Church, in *The Laos News*, Vol. 9, No. 3, July. 88-90.
- Cort, E C 1940. Letter to Drs Leber & Ruland Hooper.
- Crooks, C H 1910. Signs of awakening, in *The Laos News*, Vol. 7, No. 2, May. 54-56.
- [s a]. The imperative need of the Christian Church in Siam. S 1: Crooks, printers.
- Crooks, F B 1906. An unexpected convention, in *The Laos News*, Vol. 3, No 1, January. 13-15.
- Darum, P (ດຣຸນນາຣຸນ, ປະຈຸມ) 2000. Interview with author. Nan, Thailand.
- Davis, J R 1993. *Poles apart?* Bangkok, Thailand: Kanok Bannasan (OMF Publishers).
- 1997. *The path to enlightenment: Introducing Buddhism*. London: Hodder & Stoughton.
- Deininger, F W 1991. Folk **Buddhism** as a challenge in preaching the gospel in Thailand. **MArts** in missions, Columbia Biblical Seminary and Graduate School of Missions. Columbia, South Carolina (USA).
- DeNeui, P H 2002. *Contextualizing with Thaifolk Buddhists*. S 1: DeNeui, printers.
- Denman, K A 1904. A Laos Feast of Tabernacles, in *The Laos News*, Vol. 1, No 3, July. 62-65.
- Dodd, W C [1923]1996. *The Tai race, elder brother of the Chinese*. Bangkok, Thailand: White Lotus Press.
- Eakin, M A et al 1955. *The Eakin family in Thailand*. Bangkok, Thailand: Prachandra Press.
- Eakin, P 1939. Letter to C Elder.
- 1944. Mission in Thailand: Survey of stations. Paper presented at Thailand Consultative Conference, New York.
- Eakin, P [s a]. *Eakin Papers*. Chiangmai, Thailand: Eakin, printers.
- Eakin, P A & Mitrakul, C 1940. Statistics of the Mission for the year ending March 31, 1939, in *The Record of Actions of the Siam Mission of the Presbyterian Church in the U.S.A. January-December 1939. Including the regular Meeting of the Mission at Bangkok, January 13-24, 1940*. 61-65. Bangkok: Boon Ruang, Printer & Publisher.
- Editorial 1939. Editorial, in *The Siam Outlook*, Vol. 10, No. 3, July. 113.
- Edwards, B H 1997. *Revival!: A people saturated with God*. County Durham, U.K.: Evangelical Press.
- Edwards, J [1741] 1984. *The distinguishing marks of a work of the Spirit of God*, in *Jonathan Edwards on revival*. Edinburgh: The Banner of Truth Trust.
- Edwards, J H 1999. Jonathan Edwards, in Hart, D G & Noll, M A (ed), *Dictionary of the Presbyterian & Reformed tradition in America*, 90-91. Downers Grove, Illinois: InterVarsity Press.
- Elder, C 1939a. Letter to P Eakin (31 August 1939).
- 1939b. Letter to P Eakin (31 October 1939).
- 1939c. Letter to P Eakin (19 December 1939).
- 1940a. Letter to friends.
- 1940b. Letter to P C Johnson.
- 1941. Letter to the Board of Directors of McGilvary Theological Seminary.
- Ellinwood, F F 1896. Misions in Siam and Laos, in *The Missionary Review of the World*. May. 333-341.
- Excerpts from letters 1939. Excerpts from letters, in *The Siam Outlook*, Vol. 10, No. 3, July. 114-118.
- Farrington, A (ed) 2001. *Early missionaries in Bangkok: The Journals of Tomlin, Gutzlaff and Abeel 1828-1832*. Bangkok, Thailand: White Lotus Press.
- Ferguson, S B , Wright, D F & Packer, J I 1998. *New Dictionary of Theology*. Leicester, England: Inter-Varsity Press.

- Fitzmier, J R 1990. Old School Presbyterians, in Reid, D G et al (ed), *Dictionary of Christianity in America*, 842-843. Downers Grove, Illinois: InterVarsity Press.
- Fraser, M R 1990. New Measures, in Reid, D G et al (ed), *Dictionary of Christianity in America*, 817. Downers Grove, Illinois: InterVarsity Press.
- Froehlich, K 1991. Church history and the Bible, in *Lutheran Quarterly*, No. 5, Summer. 127-142.
- Fuller, G 1939. Letter to L S Hanna.
 ———1941. Letter to the Executive Secretary and the Executive Committee.
- Fuller, P H 1932. The Siamo-Burmese-American Gospel Team in Siam, in *The Siam Outlook*, Vol. 8, No. 2, April. 66-68.
- Gitisarn, B 1936. A Chinese evangelist, in *The Siam Outlook*, Vol. 12, No. 3, July. 128-129.
 ———(กิตติสาร, บุญมาก) 1979. Interview with C Hiranphant (OHT 73/79). Chiangmai, Thailand.
- Grudem, W 1994. *Systematic theology: An introduction to biblical doctrine*. Leicester, England: Inter-Varsity Press.
- Guelzo, A C 1990. New Side Presbyterians, in Reid, D G et al (ed), *Dictionary of Christianity in America*, 821. Downers Grove, Illinois: InterVarsity Press.
 ———1999. Old School Presbyterians, in Hart, D G & Noll, M A (ed), *Dictionary of the Presbyterian & Reformed tradition in America*, 180-182. Downers Grove, Illinois: InterVarsity Press.
- Gustafson, J W 1970. Syncretistic rural Thai Buddhism. MArts in missions, The Faculty of the School of World Mission and Institute of Church Growth, Fuller Theological Seminary, Pasadena, Los Angeles (USA).
- Hall, J H 1999. Westminster Confession of Faith, in Hart, D G & Noll, M A (ed), *Dictionary of the Presbyterian & Reformed tradition in America*, 276. Downers Grove, Illinois: InterVarsity Press.
- Hanna, L S 1926. Fourth annual retreat at Khun Than, in *The Siam Outlook*, Vol. 6, No. 1, July. 22-24.
 ———1939a. Letter to C Elder.
 ———1939b. Letter to friends.
 ———[s a]. *Evangelistic work in Siam*. Bangkok, Thailand: The Rajawongse Printing Works.
- Harding, W H (ed) 1913. *Revivals of religion: Lectures by Charles Grandison Finney*. London: Morgan and Scott Ld.
- Hardman, K J 1994. *Seasons of refreshing: Evangelism and revivals in America*. Grand Rapids, Michigan: Baker Books.
- Hart, D G 1999. Presbyterians and revivals, in Hart, D G & Noll, M A (ed), *Dictionary of the Presbyterian & Reformed tradition in America*, 216-218. Downers Grove, Illinois: InterVarsity Press.
- Harvey, P 1991. *An introduction to Buddhism: Teachings, history and practices*. Cambridge: Cambridge University Press.
- Hastings, A 1999. *The construction of nationhood: Ethnicity, religion and nationalism*. Cambridge, United Kingdom: Cambridge University Press.
- Heinze, R I 1982. *Tham Khwan: How to contain the essence of life. A socio-psychological comparison of a Thai custom*. Singapore: Singapore University Press.
- Heuser, F J 2000. Do Presbyterians really learn from anything from their history?, in *Journal of Presbyterian History*, Vol. 78, No 1, Spring. 103-108.
- Hiebert, P G 1988. *Anthropological insights for missionaries*. Grand Rapids, Michigan: Baker Book House.
 ———[1994] 2002. *Anthropological reflections on missiological issues*. Grand Rapids, Michigan: Baker Books.

- Hughes, P J 1989. *Proclamation and response: A study of the history of the Christian faith in Northern Thailand*. Chiangmai, Thailand: Payap University Archives, Payap University.
- Humphreys, C [1962] 1976. *A popular dictionary of Buddhism*. London: Curzon Press.
- Interpretation of the statistics for Siam [s a]. Interpretation of the statistics for Siam. S 1: s n.
- Jaisuk, K (ใจสุข, คำดี) 2000. Interview with author. Nan, Thailand.
- Johnson, A R [s a]. *Wrapping the good news for the Thai: Some suggestions for a contextualized presentation of the gospel in Thai society*. S 1: Johnson, printers.
- Johnstone, P , Mandryk, J & Johnstone, R 2001. *Operation world: 21st century edition*. Cumbria, UK: International Research Office, WEC International.
- Jumsai, M L M 2000. *Popular history of Thailand*. Bangkok, Thailand: Chalermnit.
- Kaiser, W C 1999. *Revive us again: Biblical insights for encouraging spiritual renewal*. Nashville, Tennessee: Broadman & Holman Publishers.
- Kane, J H 1982. *A concise history of the Christian world mission: A panoramic view of missions from Pentecost to the present*. Grand Rapids: Baker Book House.
- Kanjacnatthiti, S (กาญจนาพันธุ์, สุพรรณิณี) 1964. The role of the missionaries in Thailand from the reign of King Rama III to the reign of King Rama V (บทบาทของมิชชันนารีในประเทศไทยตั้งแต่รัชกาลที่๓ ถึงรัชกาลที่๕ & แห่งกรุงรัตนโกสินทร์). MArts thesis, Department of History, Chulalongkorn University (จุฬาลงกรณ์มหาวิทยาลัย แผนกวิชาประวัติศาสตร์), Bangkok (Thailand).
- Kedourie, E 1970. *Nationalism in Asia and Africa*. New York: The World Publishing Company.
- Kennedy, J 1968. *Asian nationalism in the twentieth century*. London: Macmillan.
- Keyes, C F 1987. Thai religion, in Eliade, M et al (ed), *The Encyclopedia of Religion*, New York: Macmillan Publishing Company, Vol. 14, 416-421.
- Kho, S 1999. Interview with author. Maesai, Thailand.
- Kilian, J 1993. *Form and style in theological texts: A guide for the use of the Harvard Reference System*. Pretoria: University of South Africa.
- Kim, H G 1998. Han Sangdong and Reformed spirituality in the Korean Presbyterian Church (1920-1970). ThD thesis, University of Stellenbosch (South Africa).
- Kim, H K (김홍구) 2000. *Introduction to Thai studies*. Pusan , , , Korea: Pusan University of Foreign Studies Press (부산외국어대 학교 출판부).
- Kim, J W 1985. Third world mission-church relationship: A Korean-Thai model. D Miss thesis, Trinity Evangelical School, Deerfield, Illinois (USA).
- Kim, S I 1980. *The unfinished mission in Thailand: The uncertain Christian impact on the Buddhist heartland*. Seoul, Korea: East-West Centre for Missions Research & Development.
- Kim, S S 1997. A study of the biblical concepts of revival and the Pyeng Yang revival of 1907. ThD thesis, International Theological Seminary, Los Angeles (USA).
- Kirsch, A T 1981. Notes on Thai religion, in Central Thai Language Committee (ed), *Clues to Thai culture and to cross cultural adjustment, communication and innovation*, 146-163. Bangkok, Thailand: OMF.
- Kohn, H [1932] 1969. *Nationalism and imperialism in the hither East*. New York: Howard Fertig.
- Komin, S 1991. *Psychology of the Thai people: Values and behavioral patterns*. Bangkok, Thailand: Research Center National Institute of Development Administration (NIDA).
- Koyama, K 1974. *Waterbuffalo theology*. London: SCM Press Ltd.
- Koydul, V 1990. The history and growth of the Church of Christ in Thailand: An evangelistic perspectives. MTh in Missiology thesis, Fuller Theological Seminary, School of World Mission, Pasadena, Los Angeles (USA).
- Kraft, C H 1989. *Christianity with power: Your worldview and your experience of the supernatural*. Ann Arbor, Michigan: Servant Publications.

- Kromamun Bidyalabh, D N 1965. *A history of Buddhism in Siam*. Bangkok, Thailand: The Siam Society.
- Kusalasaya, K 2001. *Buddhism in Thailand: Its past and its present*. Bangkok, Thailand: Mental Health Publishing House.
- Lampang Station 1932. Lampang Station, in *The Siam Outlook*, Vol. 8, No. 1, January. 37-43.
- Lampang 1937. Lampang, in *The Siam Outlook*, Vol. 13, No. 1, January. 31-36.
- Landon, K P 1939. *Thailand in transition: A brief survey of cultural trends in the five years since the revolution of 1932*. Chicago, Illinois: The University of Chicago Press.
- Lawson, J G (ลอร์สัน, เจ. กิลคริสต์) 1966. *Deeper experiences of famous Christians (ประสบการณ์ของคริสเตียนคนสำคัญ)*. Bangkok (กรุงเทพฯ), Thailand: Charansnitwongse Press (โรงพิมพ์จรัสนิทวงศ์).
- Lee, K U (ลี, เคียว อุก) 1996. The promulgation of Christianity and the response of native people in South-East Asia 1551-1990 (การเผยแผ่ศาสนาคริสต์กับการตอบสนองของชาวพื้นเมืองในเอเชียตะวันออกเฉียงใต้ระหว่าง ค.ศ.1551-1990). MA thesis, Faculty of Arts, Thammasat University (มหาวิทยาลัยธรรมศาสตร์ คณะศิลปศาสตร์), Bangkok (Thailand).
- Lee, M J (이문장) 2002. Breaking away from the Western image of Christianity (기독교 이미지의 탈서구화), in *The Ministry & Theology 신학*, January, 48-57
- Lingle, W L & Kuykendall, J W 1978. *Presbyterians: Their history and beliefs*. Atlanta: John Knox Press.
- Liu, Y L (ed) 1982. *Anecdotes and sayings of John Sung (宋尚節言行錄)* Hong Kong (香港): China Alliance Press (宣道出版社).
- Lloyd-Jones, D M 1972. *Preaching and preachers*. Grand Rapids, Michigan: Zondervan Publishing House.
- 1986. *Revival: Can we make it happen?* Hants, UK: Marshall Pickering.
- 1987. *The Puritans: Their origins and successors*. Edinburgh: The Banner of Truth Trust.
- Loetscher, L A 1978. *A brief history of the Presbyterians*. 4th ed. Philadelphia: The Westminster Press.
- Logan, S T 1999. Gilbert Tennent, in Hart, D G & Noll, M A (ed), *Dictionary of the Presbyterian & Reformed tradition in America*, 257-258. Downers Grove, Illinois: InterVarsity Press.
- Longfield, B J 1991. *The Presbyterian Controversy: Fundamentalists, Modernists, and Moderates*. New York: Oxford University Press.
- Lord, D C 1969. *Mo Bradley and Thailand*. Grand Rapids, Michigan: William B Eerdmans Publishing Company.
- Lorgunpai, S 1995. World lover, world leaver: The book of Ecclesiastes and Thai Buddhism. PhD thesis, The Faculty of Divinity, New College, University of Edinburgh. Edinburgh (UK).
- Lovelace, R F 1979. *Dynamics of spiritual life: An evangelical theology of renewal*. Downers Grove, Illinois: Inter-Varsity Press.
- Lyall, L T [1954] 1965. *John Sung*. London: China Inland Mission Overseas Missionary Fellowship.
- 1985. *God reigns in China*. London: Hodder and Stoughton.
- Mäkelä, J 2000. *Khrischakssara: The independent churches in Thailand, their historical background, contextual setting, and theological thinking*. Abo, Finland: Abo Akademi University Press.
- Marks, B & Mewhinney, S 1981. *Awakening in Asia*. San Bernardino, CA: Here's Life Publishers.
- Marsden, GM & Longfield, B J 1990. Fundamentalist-Modernist controversy, in Reid, D G et al (ed), *Dictionary of Christianity in America*, 466-468. Downers Grove, Illinois: InterVarsity Press.

- McConnell, C D 2000. Third World, in Moreau, A S et al (ed), *Evangelical Dictionary of World Missions*, Grand Rapids, Michigan: Baker Books, 955-956.
- McCord, M C 1926. Life at the Bible school, in *The Siam Outlook*, Vol. 5, No. 4, April. 140-141.
- McFarland, B 1937. The Second General Assembly, in *The Siam Outlook*, Vol. 13, No. 3, July. 123-128.
- McFarland, G B (ed) [1928] 1999. *Historical sketch of Protestant missions in Siam 1828-1928*. Bangkok, Thailand: White Lotus.
- McGavran, D A 1980. *Understanding church growth*. Grand Rapids, Michigan: William B Eerdmans Publishing Company.
- McGilvary, D 1894. Siam and Laos, Malaysia, unoccupied field, Buddhism, in *The Missionary Review of the World*. May. 373-377.
- 1912. *A halfcentury among the Siamese and the Lao: An autobiography*. New York: Fleming H Revell Company.
- McKean, J W 1907. The Me Dawk Deng Convention, in *The Laos News*, Vol. 4, No. 2, April. 45-48.
- McKim, D K 1996. *Westminster Dictionary of Theological Terms*. Louisville, Kentucky: Westminster John Knox Press.
- Meakin, E B 1896. Gospel work in Siam, in *The Missionary Review of the World*, Vol. 9 New Series & Vol. 19 Old Series, January. 43-46.
- Meeting of North Laos Presbytery 1909. Meeting of North Laos Presbytery, in *The Laos News*, Vol. 6, No. 2, May. 59-60.
- Mejudon, N 1997. Meekness: A new approach to Christian witness to the Thai people. DMiss thesis, Faculty of the E Stanley Jones School of World Mission and Evangelism, Asbury Theological Seminary, Kentucky (USA).
- Miller, E S 1981. The Christian missionary: Agent of secularization, in Central Thai Language Committee (ed), *Clues to Thai culture and to cross cultural adjustment, communication and innovation*, 70-75. Bangkok, Thailand: OMF.
- Mole, R L 1973. *Thai values and behavior patterns*. Rutland, Vermont: Charles E Tuttle Company.
- Moorhead, J H 2000. The "Restless Spirit of Radicalism": Old School fears and the schism of 1837, in *Journal of Presbyterian History*, Vol. 78, No 1, Spring. 19-33.
- Mouton, E 2003. Interview with author. Stellenbosch, South Africa.
- Murray, I H 1990. *David Martyn Lloyd-Jones: The fight of faith 1939-1981*. Edinburgh: The Banner of Truth Trust.
- 1994. *Revival and revivalism: The making and marring of American evangelicalism 1750-1858*. Edinburgh: The Banner of Truth Trust.
- 1998. *Pentecost—Today?: The biblical basis for understanding revival*. Edinburgh: The Banner of Truth Trust.
- Nishimoto, R (นิชิโม, โรเบิร์ต) 1996. *History of Pentecostals and Charismatics in Thailand 1946-1996 (ประวัติเพ็นเทคอสต์และคาริสมติกในประเทศไทย 1946-1996)*. Bangkok (กรุงเทพฯ), Thailand: Prachumthong Printers (ประชุมทองการพิมพ์).
- O.M.F. (โอ.เอ็ม.เอฟ.) 1962. *Dr Sung still speaks (ดร.ซงยังพูดอยู่)*. Bangkok (กรุงเทพฯ), Thailand: Charansnitwongse Press (โรงพิมพ์จรัสสินทวงศ์)
- Orr, J E 1981. *The re-study of revival and revivalism*. Pasadena, Los Angeles: Fuller Theological Seminary.
- Other evangelistic activities 1926. Other evangelistic activities, in *The Siam Outlook*, Vol. 5, No. 3, January. 57-67.
- Palmer, M et al 2002. *The Times world religions*. London: Times Books.

- Panikkar, K M 1970. *Asia and western dominance: A survey of the Vasco Da Gama Epoch of Asian history 1498-1945*. London: George Allen & Unwin Ltd.
- Park, D B 1905. The first Christian Convention in Nan, in *The Laos News*, Vol. 2, No 3, July. 48-50.
- Park, Y K (박용규) 2000. *The great revivalism in Korea: Its history, character, and impact 1901-1910*. Seoul (서울), Korea: Word of Life Books (생명말씀사).
- Personal and Otherwise 1907. Personal and Otherwise, in *The Laos News*, Vol. 4, No. 1, January. 4.
- 1912. Personal and Otherwise, in *The Laos News*, Vol. 9, No. 2, April. 37-50.
- 1913. Personal and Otherwise, in *The Laos News*, Vol. 10, No. 1, January. 15-16.
- Petchsongkram, W 1975. *Talk in the shade of the Bo tree: Some observations on communicating the Christian faith in Thailand*. Bangkok, Thailand: Thai Gospel Press.
- Phantuphong, D (พันธุพงศ์, ดวงชื่น) 1934. News of Hooei Rai Church (ข่าวคริสตจักรห้วยไร่แพร่), Phrae, in *The Church News (ข่าวคริสตจักร)* Vol. 4, October. 61-64.
- Phantuphong, T (พันธุพงศ์, ทองคำ) 1933. House Party ceremony in Phrae Province (พิธีเข้าสัปดาห์ที่จังหวัดแพร่), in *The Church News (ข่าวคริสตจักร)*, Vol. 5, November. 27-30.
- Phetchaburi Station 1931. Phetchaburi Station, in *The Siam Outlook*, Vol. 7, No. 1, January. 16-20.
- Phillips, H P 1966. *Thai peasant personality: The patterning of interpersonal behavior in the village of Bang Chan*. Berkeley and Los Angeles: University of California Press.
- Phuttharaksa, S 1981. Thai history lecture, in OMF Central Thai Language Committee (ed), *Clues to Thai culture and to cross cultural adjustment, communication and innovation*, 214-229. Bangkok, Thailand: OMF.
- Pongsanoi, M (พงศ์น้อย, เมี้ยน) 1999. Interview with author. Chiangmai, Thailand.
- Pongsanoi, S 1938a. Letter to Mrs G Fuller.
- 1938b. Letter to P Eakin.
- (พงศ์น้อย, สุข) 1939. The Voice of Trang Church (เสียงคริสตจักรตรัง), in *The Church News (ข่าวคริสตจักร)*, Vol. 10, January. 17-23.
- (พงศ์น้อย, สุข) 1968. *An amazing vision: the biography of John Sung (นิมิตรประหลาด: foiiizwira-im. โยฮัน ซง)*. Bangkok (กรุงเทพฯ), Thailand: Prasert Bookstore (ประเสริฐบรรณาคาร).
- Pongudom, P (พงศ์อุดม, ประสิทธิ์) 1984. *The history of the Church of Christ in Thailand (ประวัติศาสตร์สภาคริสตจักรในประเทศไทย)*. Bangkok (กรุงเทพฯ), Thailand: Chuanphim Publisher (โรงพิมพ์ชวนพิมพ์).
- 1996. *Nantaburi Srinakhon Nan: History of Society and Christianity (นันทบุรีศรีนครน่าน: ประวัติศาสตร์fam และคริสตศาสนา)* Chiangmai (เชียงใหม่), Thailand: History Department of the Church of Christ in Thailand (ฝ่ายประวัติศาสตร์ f1m^..luiJTzmfl'lvitj).
- Prebish, C S 1988. Buddhism, in Lippy, C H & Williams, P W (ed), *Encyclopedia of the American religious experience: Studies of traditions and movements*, Vol. 2, 669-682. New York: Charles Scriber's Sons.
- Prichakul, C (ปรัชากุล, ชลิต) 1985. Interview with C Hiranphant (OHT 7/85). Trang, Thailand.
- Rheenen, G V 1991. *Communicating Christ in animistic contexts*. Grand Rapids, Michigan: Baker Book House.
- Riss, R M 1988. *A survey of 20th-century revival movements in North America*. Peabody, Massachusetts: Hendrickson Publishers.
- Roberts, Richard Owen 1991. *Revival!* Wheaton, Illinois: Richard Owen Roberts, Publishers.
- Ross, M F 2000. *Prelude to revival: Disenculturating the church in preparation for renewal using the principles and promises of Isaiah 56-66*. A seminar delivered by Michael F Ross twenty-eighth PCA General Assembly, June 20, 2000.

- Roxborough, J 2000. Two-Thirds World, in Moreau, A S et al (ed), *Evangelical Dictionary of World Missions*, Grand Rapids, Michigan: Baker Books, 975-976.
- Rungrueangwong, B (รุ่งเรืองวงศ์,บุญมี) 1979. Interview with C Hiranphant (OHT 14/74). Chiangmai, Thailand.
- Schubert, W E 1976. *I remember John Sung*. Singapore: Far Eastern Bible College Press.
- Seigle, A G 1939. Editorial, in *The Siam Outlook*, Vol. 10, No. 4, October. 163.
- Seigle, J Y 1939. Annual reports committee, in *The Record of Actions of the Siam Mission of the Presbyterian Church in the U.S.A. January-December 1938*, 51-55. Bangkok, Thailand: Boon Ruang, Printer & Publisher.
- Schubert, W E 1976. *I remember John Sung*. Singapore: Far Eastern Bible College Press.
- Shenk, W R 1990. Church Growth Movement, in Reid, D G et al (ed), *Dictionary of Christianity in America*, 271-272. Downers Grove, Illinois: InterVarsity Press.
- Shin, H S 1990. *The thought and life of Hinayan Buddhism*. Bangkok, Thailand: Kanok Bannasan (OMF Publishers).
- Siam, a Presbyterian responsibility [s a]. Siam, a Presbyterian responsibility. S 1: s n.
- Siam missionary personnel [s a]. Siam missionary personnel. S 1: s n.
- Simpson, J A & Weiner, E S C 1989. *Oxford English Dictionary*. 2nd ed. Vol. 13. Oxford: Clarendon Press.
- Singhanetra, J 1939a. Chiangmai participated, in *The Siam Outlook*, Vol. 10, No. 4, October. 164-167.
- (สิงหนะตร, จินดา) 1939b. The new revival of Dr John Sung (การฟื้นในใหม่แห่ง ดร.โยฮัน ซง), in *The Church News (ข่าวคริสตจักร)*, Vol. 8. August. 25-27.
- 1939c. The work and results of the Chiengmai witnessing bands, in *The Siam Outlook*, Vol. 10, No. 4, October. 172-174.
- 1939d. Letter to P Eakin (22 August 1939).
- 1939e. Letter to P Eakin (20 September 1939).
- (สิงหนะตร, จินดา) 1979. Interview with C Hiranphant (OHT 9/79). Chiangmai, Thailand.
- Skinner, G W 1957. *Chinese society in Thailand: An analytical history*. Ithaca, New York: Cornell University Press.
- Smith, A G 1977. *Strategy to multiply rural churches*. Bangkok, Thailand: O.M.F. Publishers.
- 1982. *Siamese gold. A history of church growth in Thailand: An interpretative analysis 1816-1982*. Bangkok: Kanok Bannasan.
- 2001. *Buddhism through Christian eyes*. Littleton, CO: Overseas Missionary Fellowship (USA) Inc.
- Smylie, J H 1996. *A brief history of the Presbyterians*. Louisville, Kentucky: Geneva Press.
- South-East Asia 1940. South-East Asia, in *The International Review of Mission*, Vol. 29, 23-25.
- 1941. South-East Asia, in *The International Review of Mission*, Vol. 30, 23-28.
- 1942. South-East Asia, in *The International Review of Mission*, Vol. 31, 20-22.
- 1947. South-East Asia, in *The International Review of Mission*, Vol. 36, 17-21.
- Starling, L 1911. Rev Daniel McGilvary, D. D., in *The Laos News*, Vol. 8, No 4, October. 113-116.
- Stout, H S 1990a. New Lights, in Reid, D G et al (ed), *Dictionary of Christianity in America*, 816-817. Downers Grove, Illinois: InterVarsity Press.
- 1990b. Old Lights, in Reid, D G et al (ed), *Dictionary of Christianity in America*, 841. Downers Grove, Illinois: InterVarsity Press.
- Sung, J 1977. *My testimony: The autobiography of Dr John Sung*. tr by Z Symonds. Hong Kong: Living Books For All.
- 1995a. *The diaries of John Sung: An autobiography*, tr by S L Sheng. Michigan: Sheng, printers.

- 1995b. *The diary of his spiritual life of Dr John Song* (靈歷集光: 主僕宋尚節的日記摘抄), ed by L T Song (利未), Hong Kong (香港): Eng Yu Evangelistic Mission (恩雨出版部).
- [s a]. *40 John Sung revival sermons*, 8 vols. tr by T Tow. Singapore: Far Eastern Bible College Press.
- Suriyakham, S K 1932. **Siamo-Burmese** Gospel Team, in *The Siam Outlook*, Vol. 8, No. 2, April. 64-66.
- Swanson, H R (ed) 1982. *To what extent?: Incarnation and the Thai context*. Chiangmai, Thailand: Manuscript Division, Payap College.
- 1984. *Khrischak muangnua: A study in Northern Thai church history*. Bangkok, Thailand: Chuan Printing Press.
- 1991. *Towards a clean church: A case study in nineteenth-century Thai church history*. Chiangmai, Thailand: Office of History, Church of Christ in Thailand.
- (สาอนสัน, เซอร์บิท.อาร์.) 1995. *History of the pastoral care of the church: Church of Christ in Thailand, Draft Version* (ประวัติศาสตร์การอภิบาลคริสตจักรสภาคริสตจักรในประเทศไทย ฉบับร่าง). Chiangmai (เชียงใหม่), Thailand: History Department of the Church of Christ in Thailand (ฝ่ายประวัติศาสตร์สภาจ.ในประเทศไทย).
- 2002. Interview with author. Chiangmai, Thailand.
- Swearer, D K 1987. Buddhism in Southeast Asia, in Eliade, M et al (ed), *The Encyclopedia of Religion*, New York: Macmillan Publishing Company, Vol. 2, 385-400.
- Sweet, W W 1965. *Revivalism in America: Its origin, growth and decline*. Gloucester, Mass. : Peter Smith.
- Syamananda, R 1988. *A history of Thailand*. Bangkok, Thailand: Chulalongkorn University.
- Tambiah, S J 1970. *Buddhism and the spirit cults in North-East Thailand*. Cambridge: The University Press.
- Terwiel, B J 1991. *A window on Thai history*. Bangkok, Thailand: Duang Kamol Book House.
- The American Presbyterian Mission 1940. *Record of actions of the Thailand Mission of the Presbyterian Church in the U.S.A.: January—December 1939*. Bangkok, Thailand: Boon Ruang, Printer & Publisher.
- The Biederwolf meetings 1924. The Biederwolf meetings, in *The Siam Outlook*, Vol. 4, No. 1, July. 9-10.
- The Board of Foreign Missions of the Presbyterian Church in the United States of America, 1939. Letter to the Siam Mission.
- The Burmese Gospel Team 1930. The Burmese Gospel Team, in *The Siam Outlook*, Vol. 15, No. 15, October. 456-460.
- The distinct missionary responsibility of the Presbyterian Church in the U.S.A. 1907. The Distinct Missionary Responsibility of the Presbyterian Church in the U.S.A., in *The Laos News*, Vol. 4, No. 1, January. 12-16.
- The Office of the General Assembly 1994. *The constitution of the Presbyterian Church (U.S.A.): Part I book of confessions*. Louisville, KY: The Office of the General Assembly.
- Thomas, I D E 1997, *God's harvest: The nature of true revival*. Wales, UK: Gwasg Bryntirion Press.
- Toktaeng, J (ตกแต่ง, จุฬินทร์) 1984. *Spread of the teaching in the middle of the 20th century* (การแพร่ธรรม กึ่งศตวรรษแรกที่ 20). Bangkok (กรุงเทพฯ), Thailand: Suphanit Stationery and Printing (สุภณิตยส์เทซึ้นเนอจึ์และการพิมพ์).
- Tow, T 1985. *John Sung my teacher*. Singapore: Christian Life Publishers.
- 1988. *The Asian awakening*. Singapore: Christian Life Publishers.

- Trollinger, W V 1999. William Edward Biederwolf, in Hart, D G & Noll, M A (ed), *Dictionary of the Presbyterian & Reformed tradition in America*, 37-38. Downers Grove, Illinois: InterVarsity Press.
- Vella, W F & Vella, D B 1978. *Chaiyo!: King Vajiravudhand the development of Thai nationalism*. Honolulu: The University Press of Hawaii.
- Verkuyl, J 1978. *Contemporary missiology: An introduction*, tr and ed by D Cooper. Grand Rapids, Michigan: William B Eerdmans Publishing Company.
- Wagner, P 2001. *Good news for Buddhists: A model introducing the good news of salvation through Jesus Christ from a Theravada Buddhist perspective*. Chiangmai, Thailand: Wagner, printers.
- Wallis, A 1956. *In the day of Thy power: The scriptural principles of revival*. London: Christian Literature Crusade.
- Watson, D 1977. *I believe in evangelism*. London: Hodder and Stoughton.
- Weber, T P 1990. Henry Sloane Coffin, in Reid, D G et al (ed), *Dictionary of Christianity in America*, 295-296. Downers Grove, Illinois: InterVarsity Press.
- Weeks, L B 1990. Presbyterian Church (U.S.A.), in Reid, D G et al (ed), *Dictionary of Christianity in America*, 931-932. Downers Grove, Illinois: InterVarsity Press.
- Wells, K E 1958. *History of Protestant work in Thailand 1828-1958*. Bangkok: Church of Christ in Thailand.
- 1960. *Thai Buddhism: Its rites and activities*. Bangkok, Thailand: The Christian Bookstore.
- 1970. *Thailand and the Christian faith*. Bangkok, Thailand: The Department of Christian Education and Literature Church of Christ in Thailand.
- Westerkamp, M 2000. Division, dissention, and compromise: The Presbyterian church during the Great Awakening, in *Journal of Presbyterian History*, Vol. 78, No 1, Spring. 3-18.
- Whiteman, C W 1990a. Harry Emerson Fosdick, in Reid, D G et al (ed), *Dictionary of Christianity in America*, 446-447. Downers Grove, Illinois: InterVarsity Press.
- 1990b. Scofield Reference Bible, in Reid, D G et al (ed), *Dictionary of Christianity in America*, 1057-1058. Downers Grove, Illinois: InterVarsity Press.
- Williamson, G I 1964. *The Westminster Confession of Faith for study classes*. Philadelphia: Presbyterian and Reformed Publishing Co.
- Wilson, M 1905. First Christian Convention in Lakawn, in *The Laos News*, Vol. 2, No 2, April. 24-26.
- Wyatt, D K 1984. *Thailand: A short history*. Chiangmai, Thailand: Silkworm Books.
- Yung, H 1997. *Mangoes or bananas?: The quest for an authentic Asian Christian theology*. Oxford: Regnum Books International.
- Zürcher, E 1962. *Buddhism: Its origin and spread in words, maps and pictures*. London: Routledge & Kegan Paul.

INTERNET RESOURCE

Presbyterian Family Connection. http://www.history.pcusa.org/pres_hist/connection2.pdf